

Secret Of Sankhya: Acme Of Scientific Unification.

# Secret Of Sankhya: Acme Of Scientific Unification

By G. Srinivasan

Transliterated From

## The Sankhya Karika

By Ishwara Krishna

Secret Of Sankhya: Acme Of Scientific Unification.

Table Of Contents Part II

Table Of Contents .....	2
Table Of Figures .....	4
Preface .....	7
Introduction To The Sankhya Karika.....	24
A Tribute To Maharishi Kapila .....	49
Compatibility With Science .....	53
Simplified View .....	65
Background Of Sankhya.....	76
Clarity Of Thought.....	91
Special System Of Proof.....	103
The Missing Count .....	118
Summary Of Suthras. ....	138
Detailed Analysis Of Suthras. ....	155
Axiomatic Mathematics From Suthras.....	399
Power House Of The Universe.....	411
Astrology, Ayurveda, Parapsychology are Axiomatic .....	433
The Selfcharging Battery System .....	440
Appendix 1: Sankhya Translations Compared .....	449
Appendix 2: Origin Of The Vedas.....	467
Appendix 3: The Siddhi Meditative process.....	511
Appendix 4: Sankhya And Einstein .....	523
Appendix 5: Age Of The Vedas. ....	546

Secret Of Sankhya: Acme Of Scientific Unification.

Appendix 5A: Age Of The Vedas.....	556
Appendix 6: Sanskrit Language. ....	557
Appendix 7: Lexicon Of Sanskrit Terminology.....	563
Index .....	572
Symbols & Definitions.....	573
References .....	578

Secret Of Sankhya: Acme Of Scientific Unification.

Table Of Figures

Fig: The First Slope Of An Interaction.....	29
Fig. Concept Of Static Potential Fields.....	34
Fig: Elemental Space In Cubic Form .....	66
Fig: The Closed Substratum Of Space .....	106
Fig: Concept Of Vanishing Counts .....	120
Fig: The Guna Diagram.....	161
Fig: Axiomatic Cyclic Limit Of 10 Counts.....	165
Fig: Doubling Spectrum By 7. ....	172
Fig: Discriminative Ability.....	178
Fig: The Moolaprakriti Concept.....	185
Fig: Moolaprakrithi To Purusha Transition.....	186
Fig: The Purusha Moolaprakrithi Formations.....	186
Fig: Aggregation Of Space Components. ....	193
Fig: Prakrithi Vikrithi Nodes In Purusha.....	195
Fig: The Purusha Andhathamishra Form .....	196
Fig: The Linga-Bhaava Polarising Form. ....	201
Fig: The Thaama Intreraction In Linga Mode .....	203
Fig. Stress Transmigration.....	204

Secret Of Sankhya: Acme Of Scientific Unification.

Fig: The Bhava State Of Nuclear Interface .....	206
Fig: The Abhiman Potential Well .....	207
Fig: The Ahankar Spectrum Of 7 Ne States.....	211
Fig: Observable Phenomenon. ....	213
Fig: Transmigrating Vibratory Stresses .....	248
Fig: Self-similar Interaction. ....	267
Fig: Abhimaan Ahankar Polarisation Graph .....	276
Fig: The Mahad Vikrithi Vrithi Polarisation State .....	276
Fig: The Cerebral Process Based On Gunas. ....	285
Fig: The Radiation Phenomenon .....	294
Fig: Incremental States By Combinatorial Process.....	340
Fig: The Coherent Perpetual Oscillator . ....	388
Fig: A,B,C. The Neutral Oscillator State.....	392
Fig: Derivation Of Cyclic Counts.....	405
Fig: Third Order Damping Constraint .....	406
Fig: Concept Of Vortex As Vrithi .....	407
Fig: Axiomatic Orbit Of Major Planets. ....	409
Fig: Centre Of Resonance .....	411
Fig: Cosmic Power Structure .....	421

Secret Of Sankhya: Acme Of Scientific Unification.

Fig: Lissajou Figures Show Coherence.....	424
Fig: The Ladder Of Phenomenon.....	427
Fig: The Selfcharging Battery System.....	443
Fig: Sequential Interaction Time-Periods. ....	446
Fig.: Simultaneous Interactions.....	446
Fig: The Mahad Prakrithi/Vikrithi Exchange.....	447
Fig : The Stress Cancellation In Simultaneity.....	448

## Secret Of Sankhya: Acme Of Scientific Unification.

### Preface

Lokmanya Tilak, a mathematician, Sanskrit scholar and patriot, was intrigued by the fact that quite often translations of profound Vedic texts lacked clarity and logical precision. It failed to establish an unequivocal connection with the real world the ancient authors were trying to portray. Through his two classical works, the “The Orion” and “ The Arctic Home in the Vedas” he provided a logical explanation for the apparent lack of cogency in many Vedic translations and quite specifically the Rigveda. Most translators of that period, whether foreign or Indian, held the view that the historical time horizon of important Vedic events were within the post-glacial era or a period later than 10,000 BC.

The heuristic evidence from geological and archaeological discoveries of that period gave the impression that the process of Vedic development did not commence until later. As the Lokmanya had noticed, the translated Vedic information could not be sensibly fitted into this foreshortened time span and gave rise to speculative interpretations of such texts, that sometimes bordered on the nonsensical. The Lokmanya boldly pushed back the Vedic chronology to the pre-glacial era, based on his mathematical expertise. It not only seemed plausible but it had to be true if one had to logically reconcile numerous scientific facts the Vedas had exposed. He hypothesised that the present generations of humanity were the survivors of a global flooding cataclysm caused by the melting of glaciers in the Polar Regions.

Many ethnic and religious groups (as in Vedic and Biblical accounts of this apocalyptic event) have provided historical confirmation for such an inundation theory. He proposed that the brahminical tradition of scholarship enabled the renaissance of orally transmitted Vedic information, by the surviving generations. It was aided by

## Secret Of Sankhya: Acme Of Scientific Unification.

re-awakening their latent genetic memory through yogic practices, the possibility of which was predicted by Vedic theories. Not only was such a recovery a laudable feat in itself, but the degree of accuracy with which it has been reproduced speaks volumes for the scientific concepts of the Universe in the Vedas. Moreover, the Atharva Veda contains specific information on stellar positions that could only be reconciled by using the Lokmanya's hypothesis. The detailed proof for the foregoing premises, along with some new aspects in physics are dealt with in the appendix section of this book.

In this background, the motivation to publish "The Secret of Sankhya: Acme of Scientific Unification" came from the gradual realisation of the correctness of Vedic theories. It was backed by personal experimental confirmation of phenomenon considered impossible or a violation of established theoretical principles. Of the many, there were two benchmark confirmations, worth explaining here. The first sloka of the Rigveda theorised the availability of free energy in space, for Vedic scientific logic defined it as being substantial, dynamic and holographic; not empty and vacuous. Decoding this sloka gave the outline of a principle of triggering space instantly in an expansive mode that would produce an incremental output through self-confinement.

The Sankhya Karika by Ishwara Krishna (Sankhya), containing axiomatic theorems of logic, confirmed this possibility. Sankhya logic split interactive events in space into a sequence of cyclic oscillatory actions when observable, else it was in 'simultaneous, coherent or synchronised (apparently static)' state. The pseudo static restful state provided the ground state or 'potential sink' for higher activity levels to drift or gravitate towards it in attaining a state of equilibrium. Therefore Sankhya derived; the important corollary that there were no groups or domains of forces but it was only due to different levels of



## Secret Of Sankhya: Acme Of Scientific Unification.

simultaneous interactions. This concept provided the primary cause of gravitation as a phenomenon and with the exotic axiomatic supportive mathematics, the last vestige of intellectual and logical dissatisfaction was eliminated.

The holistic Sankhya view was that synchronisation of activity produced the static effect in a dynamic environment. Therefore, if one were to view the Universe from the 'outside' it would give the impression of a static or unit entity representing the concept of a singularity. Yet, we as the internal dwellers know and experience the gamut of phenomenon that belies the external view. For instance, we know that the sun is in a dynamic state. Yet, by virtue of its ability to act perpetually as one synchronised unit, it gives the impression of being a static or 'solid' ensemble.

The Sankhya theory presented a concept of availing abundant free energy from space by a momentary disruption of its synchronised, coherent state. Hence, a simple electric motor was constructed, without any means of creating a magnetic field, to prove that self-confinement provided the equivalent of the magnetic field. It operated at an efficiency of 'over-unity'. It meant that the rotary action did not consume any electrical energy or the input and output energy balance could be accounted for perfectly by the static circuit characteristics. It consumed the same amount of electrical energy whether it rotated or not. The rotation was obtained by disrupting the synchronised state.

This motor violated Maxwell and Faraday's laws for its high rotational speed was not dependent on a magnetic field because it did not have one. Instead of the magnetic field, the mechanical construction of the motor provided the predicted third order damping force that imitated the magnetic field, to create the rotary motion. Hence, the energy loss induced by the production of a time-varying magnetic field was eliminated. It proved that not only were

## Secret Of Sankhya: Acme Of Scientific Unification.

Vedic principles correct but also introduced a new concept that sudden differential-expansion of space, caused by triggered impulses as conceptualised in Sankhya, provided self-confinement that created the magnetic type of field. It provided the motive for relative motion.

Sankhya logic also showed that sudden acceleration produced a third order damping force in space. However, that restraining force has not been hypothesised in physics till today, though in the Hamiltonian of an oscillator there is an arbitrary restoring factor. It was the motivating cause of the velocity dependant magnetic phenomenon. In fact Special Relativity arrived at the same conclusion by predicting that velocity of light cannot be exceeded but could not derive a constraining force to substantiate it through the concept of an empty space. However, extending the principle of relativity, mathematically, to the forbidden zone of 'simultaneity', confirms the existence of the third order-damping interaction. It was the unification point of all forces hidden in the mathematics of self-similarity. Physics has discovered neither theoretically nor experimentally the existence of such a force. However, the anomalies at the Planckian level of interactions, superconductivity, ferromagnetism and the EPR paradox, demands such a phenomenon to balance out the highly energetic behaviour of so called empty space.

The reasons for this failure were elementary. The current scientific concept of an empty-space cannot logically justify the existence of any reactive property in it. Moreover, the third order-damping phenomenon followed principles of self-similarity and scale invariance at the fundamental level; the mathematics for which existed in Sankhya but not in physics. For the latter relied totally on the 'infinitesimal displacement' with its consequential commitment to the principle of uncertainty. Sankhya principles proved that perpetual cyclic motion must exist if the input and output energy balance was equal.

## Secret Of Sankhya: Acme Of Scientific Unification.

Continuous cyclic oscillations would be possible if the difference in space-time parameter was kept at 'zero' every instant, by a phase reversed synchronous self-interaction. Sankhya showed that such was the case in a holographic interactive state, which followed self-similar & coherent laws in a simultaneous mode.

It was very evident that the laws in space followed linear principles but the concept of a standard time or velocity introduced the asymptotic behaviour. The principles were explained and the motor action demonstrated by the author and his eldest son, at the Gravitation energy conference at Hanover in '87. At this venue, another Indian experimenter, a scientific officer from the Indian Atomic Energy establishment, demonstrated a similar over unity current producing reaction-less generator (that violated the Maxwell / Faraday laws,). Though it was his private exhibit produced through personal sacrifice of time and money, he was amply rewarded, for it won him a prize for scale of performance. At the time of this writing he had field tested a model at 200% efficiency. His late mentor, an American nuclear physicist in the U.S. had built a similar but more powerful working model (its operation was seen personally by the author at Santa Barbara). He had said it was prohibited from being privately used or publicly displayed, by the U.S. Government, on the plea that this area of research in physics was classified.

The well-publicised Newman perpetual electric motor (patented in many countries including India) was also displayed and demonstrated at Hanover. Newman was not granted a patent by the authorities in the U.S.A. as they deemed it violated energy conservation laws. Thousands of visitors witnessed the perpetual-motion motor continuously driven by its phase-reversed, self-generated power. When a sceptical physicist commented "How can it work? It violates every energy law", the inventor's representative retorted "unfortunately the motor doesn't

## Secret Of Sankhya: Acme Of Scientific Unification.

know any of your laws”! That was the truth because nature had it’s own laws but man had to learn them. It clearly indicated that physics had reached an era of transition and needed to introduce a new paradigm in scientific thinking. What was more important, man had to learn to think as nature intended for that was his real and innate strength. Sankhya taught man how to think.

The second experimental confirmation, which became a personal turning point, was from a psychic “out-of-body” experience commonly called an OBE. (The late Dr. Puharich, a lifelong researcher into paranormal phenomenon like Uri Geller’s psychokinetic powers etc, called an OBE a process of projecting the ‘mobile centre of consciousness’. Drs Raymond A. Moody and Robert Monroe among several other researchers have published such experiences of thousands of normal individuals.) This event was followed by numerous psychic events of a profound nature that provided unequivocal affirmation, intellectually and emotionally, of the veracity of Vedic principles and the tremendous lacuna in classical physics. The uniqueness of these events compelled the author to delve into the translations of the Brahmasuthra, Rigveda, Atharvaveda, Bhagavadgita and some important Upanishads. It enabled him to understand the psychic aspects of reality in a logical and rational way.

All these works, though not complete, pointed clearly to a core theoretical source, the Sankhya Karika. It was identified unequivocally as the intellectual, logical and scientific base for the field concepts in the Bhagavadgita, (mentioned in chapter 2, verse 39, as a part of the Mahabharatha epic). The author, lacking formal introduction into Sanskrit as a language, used English translations by eminent researchers as a dependable base, to fine tune and eliminate the inexactitude in terminological meanings introduced by the individual styles of researchers. He created a special lexicon, through a

12

## Secret Of Sankhya: Acme Of Scientific Unification.

computerised program of statistical and contextual decoding technique of ancient Sanskrit terms. The Pratisakhya ostensibly created by the ancient authors to aid the faultless transmission of their oral creations, proved a valuable asset in clearing the ambiguities in manuscripts produced later. As a case to point, Sankhya is spelt as Samkhya by most authors. In Sanskrit, the word is accented by the 'anuswara' character, which the Pratisakhya clearly demarcates as an ascending sound of nasal origin. The descending 'im' sound is strictly of labial origin, which classifies Samkhya into a different category, whereas 'Sankhya' means numbers, counting, reasoning etc.

The first lead came from Suthra 1 in Sankhya. Analysing the earlier works of at least 20 notable translators (both Indian and foreign) of the Sankhya Karika, provided confirmation that it was not translated, as it should have been. Almost every one of them gave a different twist to its meaning and surprisingly all had overlooked the axiomatic nature of all the Suthras. The most important axiomatic definition of space in the first Suthra, "Aikaantha-Athyantha-Atho-Abhavath" (Coherent, Perpetual, Dynamic but Unmanifest) as the substratum of phenomenon was overlooked completely by all the previous authors. That was despite a confirmatory repetition of this state in the 68<sup>th</sup> (penultimate proving) Suthra.

The reason became clear. The creator of Sankhya, Maharishi Kapila, was not only an intellectual colossus but also a thinker with an uncompromising attitude towards maintaining accuracy and preciseness. Instead of identifying space as a functional object, he defined it objectively, accurately and functionally, only by the specific characteristics required sustaining a dynamic state of existence that formed the base for both manifest and unmanifest phenomena. Further, in an extremely skilful

## Secret Of Sankhya: Acme Of Scientific Unification.

intellectual manoeuvre of elliptical negation, made that description of the substratum of space the proposition and its internally generated answer. That procedure complemented and completed the logic of the rest of the 67 Suthras, both mathematically and semantically.

In most Sanskrit verses, emphasis was created by elliptical negation, passive understatements, hyperbole, iteration, parables and unforgettable stories of fantasy. It was deemed the height of intellectual excellence if the composer, through semantics, roused the appropriate feelings accompanying a thought-form. It was the only effective way to transmit oral creations, for there is no evidence of Sanskrit in script from the pre-glacial era.

It took the present writer more than seven years to understand the true meaning behind each Suthra. It was done by a process of decoding, using the Siddhi meditative technique recommended in Sankhya. What Maharishi Kapila had demonstrated through axiomatic mathematics was that all phenomena in nature was of a holographic or coherent vibratory form. Therefore, the human mind too could reproduce every phenomenon within itself by the simplest process of bringing it to a coherent and synchronised phase, emulating a static state. He called the process Siddhi and the ensuing principles were later enunciated, defined and elaborated by Patanjali in the Yoga Suthras, particularly in the section called Samadhi pada.

Through Siddhi, the individual experienced phenomenon by creating it within his mind, which proved to be the perfect way to learn anything. One could not forget it because the coherent mental state emulated a real lifelike experience. An orchestral rendering was engraved on a flexible platter just through the point of a needle and the same fine point reproduced the sounds faithfully, as a gramophone recording. The essential concept here was the transfer of activity through resonance across a needlepoint.

## Secret Of Sankhya: Acme Of Scientific Unification.

A camera captured the universe in light across a pinhole onto a film, again through resonance. A magnifying glass burned a paper when the sun's rays were focussed on it, providing again a case of transfer of pure energy or power by resonance across millions of miles. The entire information and entertainment industry today depends on just one factor - resonance. Maharishi Kapila went just a step further. He proved through exquisite, axiomatic mathematics that so called 'matter' too was just a plain state of resonance of the components in space!

Once the logic became clear, one found the new form of integer mathematics in Sankhya gave it the preciseness that is seldom experienced in any scientific field today. The equality of two parameters could be tested to 25 decimal places prior to its confirmation. The 68 important Suthras proved to be a goldmine of factual scientific information. It provided the axiomatic mathematical logic for the fundamental process of manifestation, involving new principles and procedures leading to conclusions that crossed the boundaries of current scientific knowledge.

The 69<sup>th</sup> Suthra's explicit emphasis on the secret nature of Sankhya motivated this writer to decode the axiomatic representation in Sanskrit, rather than attempt a literal translation. The alternate approach was well validated. Surprisingly, the parent creation the Mahabharatha and Bhagavadgita, lent itself to the normal translation processes without losing its meaning. However, reviewing the existing translations (all of which followed the conventional approach) exposed the muddle, even from the very first Suthra in Sankhya. The reasons for the failure, of previous translators, to realise Sankhya's scientific base, lay in the interpretation of the very first word in the first Suthra. Dhu: kha was translated by all as pain but the contextual reference to the three Guna forces (vector-tensor states or a taut bowstring in Sanskrit) compelled one to read the real meaning as stress or

## Secret Of Sankhya: Acme Of Scientific Unification.

interactive stress. Stress meant that there was a lack of freedom to attain a balanced, equalised or comfortable state

The correct translation exposed a train of axiomatic principles that was truly outstanding. For not only every important constant in physics was derivable from a single, axiom but it also extended the horizon of physics and cosmology tremendously, literally and figuratively. Sankhya provided the axiomatic base science had been looking for. Moreover, the accuracy of its derivations far surpassed the scientifically established values that proved unequivocally Du: kha was indeed 'interactive stress' in Sanskrit, as used in the Sankhyakarika. (See 'Comparison' in the Appendix section)

The dichotomy that man experienced when confronted with eyewitness accounts of clairvoyance, telepathy, psychokinetic acts, astrological predictions, faith-healing, out-of-body experiences and a range of so called magical phenomena of both black and white varieties, could not be resolved by scientific justification. Nor could he reject it outright without labelling the witnesses as liars, cheats or whatever. The Sankhyan concept resolves such conundrums in a precise and axiomatic way. Maharishi Kapila bases the entire theory of cosmic evolution on one premise that whatever 'components' constitute space vibrate or oscillate perpetually due to axiomatic laws as a frozen hologram and all phenomenon is an outcome of this fundamental behaviour.

In simple terms a hologram is an image formed of vibrating nodes that remain in a stationery relationship to each other to maintain the form being projected. A coherent beam of light from a laser forming an interference pattern with the image of the object is recorded on a film. On reversing the process the three dimensional image is projected with the original true to life



## Secret Of Sankhya: Acme Of Scientific Unification.

properties. The remarkable feature is that even a tiny fragment of the film reproduces the whole image.

Then the corollary naturally is that all things like stellar bodies, planets, oceans, mountains, trees, animals, humans and etc. have a piece of this dynamic space, as its base or centre of existence. Sankhya showed through axioms the irrefutable connection, to this centre of a piece of cosmic real estate, as a dynamic, vibrating, perpetually oscillating link through resonance. Vibrations know no barrier, so it can pass through all mediums but a 'medium' it must be, despite relativistic remonstrations to the contrary. Learning to decode these vibrations gave man the edge in deciphering nature's secrets in the hidden and therefore forbidden domains. Though this seemed impossible it was in fact no different from deciphering through an instrument; like establishing the fact of a planet orbiting a stellar body millions of light years away, through instrumental observations. There the magical aspect disappeared because there was a 'recognised' thing called a telescope. However, the Maharishi showed that man has the equivalent power of a trillion telescopes in each of his genetic ensemble called a cell. Capping it all, Sankhya showed through a brilliant concept of resonant polarisation, that every coherent state in the substratum of space contained the powerhouse of the Universe, as the Andhathamisra state, Vedicly synonymous with the Shivashakti or the Shivalinga state of coherent power.

Man had only to learn to use these marvellous instruments by putting as many of them as possible in a state of resonance to extract the unlimited information circulating in space as vibrations. The unseemly controversy going on over astrology or ESP phenomena has no intellectual validity when viewed from the Sankhyan perspective. The centre of a human being is a perpetually vibrating piece of cosmic real estate irrevocably connected through resonance to the eternal universal interactive vibrations.

## Secret Of Sankhya: Acme Of Scientific Unification.

Like a fish in a pond reacts to a vibratory disturbance in the water, the human 'centre of awareness' is gently nudged into a nebulous reactive state by a change in the planet's angular position. The subtle signals communicate through the resonant substratum to urge the genetic ensemble to do their wont.

The foregoing may seem like magic but not after one understands the precise and rigorous mathematical Sankhyan logic. It exposes the 'how & why' of the nascent messenger of our information system, the so-called photon, that has an identifiable connection to anything and everything. Does this wonderful electronic messenger, that science has glamorised into a dual mythical state of existence and non-existence, really behave as experimentally conjectured? Sankhya puts your mind at rest by showing through axiomatic mathematics that a photon at 'rest' turns into a coherent, synchronised, spherical set of seven dynamic units or Vrithis, called neutrinos in physics. Each of which the Maharishi has defined as a Moolaprakriti or the holographic elemental unit of activity, the very foundation (yet to be discovered) for the much extolled Quantum Mechanics of today. Paradoxically Cosmic physics confirms (in a theoretical vacuum of course) that there is no place in this Universe, where there are no neutrinos, though space is declared a vacuum!

The published findings of well-known psychics like Annie Besant, Leadbeater and Cowen confirm beyond any doubt the theoretical basis of Sankhya, which portrayed all phenomena as a holographic activity. The extra-ordinarily precise sketches and numerical values of all the atoms in the periodic table, given by the experimental psychics in 1932, is an exceptional tribute to the skill of the human mind in manipulating its extra-sensory qualities. These details were published by Dr. Phillips in his book and by Dr. M. Srinivasan as an article in the newspaper 'The  
18

## Secret Of Sankhya: Acme Of Scientific Unification.

Hindu'. However, that psychic process was already defined numerically in Sankhya as a Siddhi and laid out as a perfectible system of yogic practices, by Patanjali, later.

The Sankhyan axiomatic mathematics and the psychic visions of experts prove that the holographic mode of phenomenon is the correct way to understand the universe. For it not only logically simplifies it to a mere process of counting interactions, devoid of dimensional characteristics but also eliminates the need for dimensional concepts. The mass, charge, momentum & inertia conceptual complications are arbitrary qualities, which Sankhya replaces with two simple complementary factors of cyclic time variations in the simultaneous and sequential phases. The elegance of Sankhyan thought, mathematics and accuracy would never be excelled, for it has placed itself in the position of the theory of theories. It is indeed truly gratifying to learn that the core of the popularly revered and venerated Vedic creation, the Bhagavadgita, contains in fact a profound mathematical treatise. It covers the physics of universal manifestation, presented as an understandable edition to the lay public.

Though the author had no literary pretensions, these esoteric hidden facts cried out to be exposed and therefore this book was born. The intellectual magnificence, exhibited by Maharishi Kapila in creating an axiomatic Sankhya, can rarely be excelled. There is a direct confirmation, later in the 'The Soundarya Lahiri' by the Adi Sankaracharya, of the holographic nature of the Universe, albeit through visualisation in the structural form of 'yantras'. Hence the author hastens to clarify that he does not claim any originality of Sankhyan scientific thought by publishing this book except for decoding the axiomatic mathematical structure of Sankhya and making it logically and scientifically meaningful to this generation.

Unjust criticism of the works of previous authors is neither implied nor suggested. On the contrary, this author is

## Secret Of Sankhya: Acme Of Scientific Unification.

deeply indebted to the intellectual pioneers who exposed the uncertainties of translating a pre-glacial scientific language that is certainly older than 10,000 years. (See Appendix -Vedic Age) The author, (born in 1932, graduated in Marine Engineering and extended his academic-working-experience background to include proprietary Industrial Engineering / Diagnostic / Design / Consultancy services) delved into experimenting with energy related devices as a hobby, to satisfy his inventive curiosity. These experiences led him to seek the source of fundamental power in gravitational physics. Further, deeply intrigued by the energy relationship to meditative processes, he explored Vedic scientific thought in all seriousness that finally enabled him to understand Sankhya, the theory of theories, over a span of 25 years. Based on Sankhya Suthra 37 a self-charging battery that can remain on load perpetually is undergoing a performance test currently. It will provide incontrovertible proof of Sankhya theory to scientific investigators.

Since this book is aimed at the hidden aspects of Sankhya that previous researchers did not deal with, the focus here has been shifted to explaining the new information in as many ways as possible to clarify difficult concepts. Hence, the approach here would seem different to the usual mode of treating the Sankhya Karika. Explaining the holographic concept is difficult and particularly so as the axiomatic logic of simultaneity used by Maharishi Kapila encapsulates complex modern transforms like Fourier, Laplace and Lorentz through simple combinatorial mathematics, with unprecedented accuracy. Hence all mathematical expressions are presented as solved problems with precise numerical answers shown in every case so that the reader can see at glance the impeccable nature of Sankhyan logic. Such an advanced concept demands a place for the origin of Sankhya in preglacial times, as hypothesised by the Lokmanya. For, contrarily,

20

## Secret Of Sankhya: Acme Of Scientific Unification.

post glacial scientific thinking is steeped in primitive rationalisation techniques that only seemed to attain intellectual heights in the acknowledged works of Ptolemy, Tycho Brahe, Nicolaus Copernicus and Johannes Kepler. The teetering seesaw logic of an earth-centred to sun-centred hypothesis propounded by the foregoing group of thinkers, was eminently overshadowed by Maharishi Kapila's holographic reality defined through axiomatic and combinatorial mathematics in Sankhya, eons ago. Current science may realise its full import probably in another 100 years.

Sankhya provided the axiomatic foundation for the Bhagavad Gita, which in turn gave a lay expose of the holographic field theory called Kshetrajna. Imaginative dramatisation in the Mahabharatha, enacted by gods, demons and humans, spread the unforgettable message to the people at large. Maharishi Kapila exposed the fact that basic axioms hold true for all times, which naturally endowed it with the mantle of divinity. It logically unified science and religion, the two sides of the same coin called reality. The unique, self-similar law of universal interaction called Dharma in Sankhya and the Gita, acting in three axiomatic ways called Gunas, unifies all manifestation and proves its 'spirituous' origin. An outstanding feature of Sankhya is that it precisely describes what a 'field of elemental components' is in real and mathematical terms. Modern theories have demonstrated only how a field functions but have failed to define it mathematically or physically.

Vyasa the creator of Mahabharatha, presents an impeccable dramatisation of Sankhya principles through the dialogue between Sri Krishna and Arjuna in the Bhagavadgita. It forms a model lesson in communicating difficult principles. Sankhya Suthra 21 describes the interactions, in the fundamental field or Kshetra, as the

21

## Secret Of Sankhya: Acme Of Scientific Unification.

cooperative association between a lame person and a blind one, to sustain manifestation as an oscillatory phenomenon, which forms the foundation for human spiritual concepts. Sri Krishna, the symbol of primal energy, guides Arjuna, the symbolic manipulator of human skills, in the Mahabharatha, in an allegorical setting replete with symbolic meaning. Sri Krishna's chariot (athmaan) with six horses (the senses), with Sri Krishna as the charioteer (epitome of humility with knowledge) advises Arjuna (Vrithi), to use the bow (three gunas) and arrow (the target) against his own people (absolute objectivity) to fulfill responsibility (destiny) without the stain of sinning (because a vrithi is a hologram and in any case will decay). The foregoing process symbolically presented the axiomatic law of Dharma in the dynamic field of Universal manifestation.

There is no better way than to allow this same axiomatic law of Dharma to unify the twin-polarised concepts of science and religion. Thereby, humanity would gain a thousand-fold from the benefits of a harmonised and focussed intellectual effort at raising the level of human fulfilment. The same law of Dharma would act transcendently to improve human well being in the Siddhi state of Ishwara pranidhana of Hinduism or a state of Nirvana in Buddhism. Similarly, the same law acts in a state of charismatic surrender to the will of the Creator, in Christianity, Islam and Judaism. While learning increases knowledge, it is essentially a process of memorising the outcome from past experience. What humanity needs vitally is the ability to find creative solutions for current problems, which the Siddhi state eminently provides through transcendent exchange of abundant knowledge from the field we live in. It is the essence of spirituality and Sankhya eminently demonstrates through axiomatic mathematics that it is as real and manipulatable as the concept of materiality. They are both only different phases

## Secret Of Sankhya: Acme Of Scientific Unification.

of the reality we live in. Human equality and the democratic quality of natural law demand that every human being share these rights of living without let or hindrance. Above all it provides intellectuals with a precise axiomatic foundation that unifies all apparently confrontational concepts, the lack of which currently has polarised society into a state of incompatibility.

## Secret Of Sankhya: Acme Of Scientific Unification.

### Introduction To The Sankhya Karika.

The Sankhya Karika, (Sankhya) is probably the least known of all the Vedic compositions in Sanskrit, despite the fact that it forms the foundation of the Bhagavathgita (mentioned first in chapter 2, verse 39). Chapter 2 is named Sankhya Yoga, emphasising its importance. The Sankhya Yoga is purported to be created by Maharishi Kapila. It is highly indicative that in chapter 10, verse 26, Sri Krishna, during his pedagogic dialogue with Sri Arjuna, identifies himself with Muni Kapila as the master of Siddhi. The Sankhya Karika by Ishwara Krishna mentions the authenticity of this creation in the seventy first Suthra.

There are four important reasons for its apparent lack of intellectual or religious appeal to our present, post-glacial generation. The first is its terse and ascetic structure. It contains only 72 verses, 68 of which purport to define the complete spectrum of universal manifestation. Most researchers today would prefer to deal with the voluminous Vedas, epics and Puranas, as it promised to yield information beyond expectation. However, it would take a would-be-researcher considerable courage to anticipate the extraction of a significant and meaningful content from such a small creation as Sankhya.

Secondly, one could easily misconstrue the connection between Sankhya, that stands for a process of 'counting' and the profound religious compositions, like the Vedas, Mahabharatha and Bhagavadgita. Hence, Sankhya had been shelved by the discerning researcher.

Thirdly, translators and commentators of the earlier periods projected a strong image that Sankhya was based on atheistic concepts. Consequently, it was treated, as a sequence of thought related to the physical wellbeing of humanity. This again was connected through esoteric yogic practices that was not truly religion bound.



## Secret Of Sankhya: Acme Of Scientific Unification.

Lastly, even the above three reasons would not have tended to eclipse Sankhyan principles, had there been an early translation that highlighted, in clear mathematical terms, the depth of scientific information and path breaking cosmological principles hidden in the 72 Suthras. Unfortunately, there is no explicit information on the existence of even a single translation of its exotic mathematics so far. The magnificent part was that all its scientific principles were derived purely through axiomatic mathematical logic. Maharishi Kapila displayed intellectual brilliance at its analytical best for no theory in physics today is based on axioms.

From 72 Suthras, 68 highly condensed and coded holistic theorems explain the principles operating in the field of cosmic space. It is axiomatically evolved through a special and unique intellectual technique, using a novel form of rigorous holistic logic, called integer-mathematics in a combinatorial form. It has an unparalleled procedure for logically deriving its own internal proof. Therefore, it needs no confirmation or experimental verification of its main axiomatic or self-evident principles. It not only unifies mathematically the logical cause of all manifestation at the fundamental level with a simple and exquisite numerical proof but also establishes, the most modern, path breaking idea that all phenomenon is purely of a coherent, synchronous, oscillatory or vibratory nature. It functions in a holographic mode. A hologram is a state in which all the vibrating nodes seem to remain stationary or frozen.

The overall view of a hologram being a frozen ensemble of vibrations, it can be dealt with mathematically as a dynamic entity in a static state. In addition, a unique feature of a holographic state is that every part of it resembles the whole structure due to the quality of self-similarity. A cube made up of vibrating components displays its dynamic state. Since it retains its cubic form despite its vibrations, it

## Secret Of Sankhya: Acme Of Scientific Unification.

is in a holographic state. The Sankhyan holographic view is new to physics because it treats phenomenon as a dynamic state that must be described mathematically as though it were a static ensemble. Therefore the need to bring in concepts of time varying movement was eliminated and all manifestation could be mathematically described relationally through integers using combinatorial principles. The unique advantage of combinatorial mathematics is that it is object oriented, thus transcending the need for dimensionality. The concept of dealing with dynamic phenomenon as a stationery state eliminated the complexity in mathematics. However, it brought in the need to treat it as a simultaneous activity using new principles of self-similarity and scale invariance that was simple yet accurate and axiomatic.

The foregoing principles allowed the derivation of dynamic phenomenon as interactive ratios that eliminated the need for defining dimensional aspects. Integer values representing ratios could logically increase from a ratio of one/one to one / two. That first step contained the source theorem for change in interactive ratio. A cube and a sphere had a built in equality factor. The cube had space as an equal parameter whereas a sphere had time as the measure of equality. Above all, it had the ability to describe real phenomenon in real time. Substantial objects can be verified easily but time or the interval between events was difficult to account for. The Universe could be understood if cyclic time could be accounted for accurately.

The all-important first Suthra was structured as a conditional theorem that elliptically generated an axiomatic mathematical proof in Suthra 68. It proves the very proposition it introduces as the basis for its axiomatic behaviour. By an extra-ordinary statement of logical negation in the first Suthra, the basic proposition is made applicable to every one of the 68 Suthras!

## Secret Of Sankhya: Acme Of Scientific Unification.

Through this process of elliptical negation, the entire theory is unified. For by just disproving one theorem the entire set can be shown to be in error. It establishes scientifically, through axiomatic logic that every identifiable location in space functions as a perfect and perpetual harmonic oscillator that remains in the same static location with the energy spectrum, characteristic and dynamics, of a micro-blackhole-quantum! The holographic blackhole state becomes the repository of all the interactions and so provides not only the potential for action but also forms the historical source of all information, knowledge and therefore intelligence. It can be extracted from that quantum blackhole level through decoherence and disentanglement of its coherent blackhole state in a holographic form.

The logic used by Maharishi Kapila in creating the Sankhyakarika is impeccable. Any measurement is a relational process and only a change can be measured but it takes time. The difference between the yardstick and the measured object constitutes the measured variable, which in effect is an incremental change. Holographic phenomenon is dynamic and oscillatory states are measured by cyclic time periods which then limits the process of measurement to detecting the change in the cyclic time interval. The credibility of a logical derivation is enhanced if arbitrary definitions of dimensions and postulates are avoided. Since the observer can detect or measure only a change then logically, the incremental unit of measurement itself should form the basis to derive the whole. Such a concept becomes an axiom because the observer can only detect a change and therefore has no option but to use only the observable as a yardstick. This concept pervades all of Vedic science and is apparently absent in existing sciences. Such a characteristic is defined as Swabhava in Sanskrit or the trait of self-similarity. When two or more associated parameters change at the same

## Secret Of Sankhya: Acme Of Scientific Unification.

time then, only a single ratio need be applied to all modes of operation. As an example, the arch of a bow has expansive stress on the outer side and compressive stresses on the inner side, while the string is in tension and all are balanced at every instant. The expansive, compressive and tensile stresses can be expressed by one law. Alternatively, a single variable describes the proportionality of three types of forces existing at the same time.

Such a variable should be scale invariant, self-similar and have an axiomatic relationship to the whole. At the elemental level, an interactive cycle can vary only in two ways.

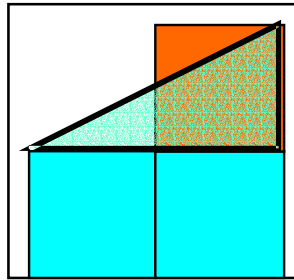

Fig: The First Slope Of An Interaction

The gradient or slope can vary as 1:1 or 1:2.  
Calculating the slope or gradient of 2 as a cyclic relational value:

$$\frac{\sqrt{1 + 2^2} - 1}{2} = 0.6180339887 \blacksquare$$

Setting x as the self similar variable:

$$\mathbf{x = 0.618034}$$

If x is the value of a measured increment then the total value 1+x must be related to the ratio of change as 1/x at the same instant of time or simultaneously. Though in physics the definition of a vector relationship does not specify that it is only valid at each instant, in real terms it is assumed that it is constant over the unit time. It emphasises the equality of the incremental value with the ratio that the incremental value forms with the whole at the **same** instant. Hence, if two or more actions take place simultaneously within the same location, it can follow only one law or scale of proportionality. Then the equation:

$$\mathbf{1+x = 1/x}$$

sets the self-similar relationship to the unit. Rewriting

$$\mathbf{1+x = 1/x \text{ or } x+x^2 = 1}$$

shows that the incremental value though unequal, yet has a relational value to the remainder as:

Secret Of Sankhya: Acme Of Scientific Unification.

$$x^2 = 1 - x.$$

The logic is that the incremental value is taken from within itself as a proportionate factor by a process of simultaneous exchange leaving behind  $1-x$  as the remaining value. Here the internal exchange can be written as

$$(1/2 + x^3/2) = x \text{ and } (1/2 - x^3/2) = x^2$$

to provide the value of  $x$  and  $x^2$ . The self-proportional or self-sufficient mode of incremental action does not violate the rigour of logic because there is no need to look outside for the means to change. It avoids dependence on anthropomorphic ideas to support the existence of a separate external agency to provide the motivation at the fundamental level and allows interactive logic to proceed axiomatically. Similarly the ratio of

$$(1 - x) / (1 + x) = x^3$$

which automatically defines the limit to change by a process of exchange from within itself. This limitation is confirmed by the difference too:

$$x - x^2 = x^3$$

While the incremental value of  $x + x^2 = 1$ , the same ratio repeats at the next level too, as  $x^2 + x^3 = x$ . The self-similar ratio is evident as the powers of  $x$ . Here the logical reason why  $x^3$  forms the limit can be explained by another example. A cube can be described as length  $L^3$  or splitting  $L$  as velocity  $V$  into time  $T$  gives the form:

$$L^3 = V^3 T^3 \qquad \mathbf{E2}$$

The limit of any change that has freedom to move or act in all direction is given by  $L^3$ . As the ratio  $L / V = T$  then  $T^3$  prescribes the limit proportional to  $L^3$ . In a self-similar interaction, the variable  $x$  has a similar function to  $T$  the time cycle.

While this limit will be proved graphically in the main Suthras,  $x^3$  sets the limit in any self-similar interaction. In terms of a rigorous logical explanation, it sets the limit of the incremental proportion  $x$  because the internal process of exchange cannot exceed  $x^3$ . If it increases, the value of  $x$

## Secret Of Sankhya: Acme Of Scientific Unification.

changes and loose it's self-similar proportionality. Since the proportionality is lost due to a change then at the precise value of  $x$ , the incremental and decremental process can go on simultaneously and endlessly. For there is neither a loss nor a gain in the process of exchange, as  $(\frac{1}{2} + \frac{x^3}{2})$  and  $(\frac{1}{2} - \frac{x^3}{2})$  add and subtract the same value from half. Therefore, at this ratio a process of change can continue endlessly or perpetually because **only** the same proportion of the cyclic time-cycle is added and subtracted cyclically. Then all the laws of manifestation can be equated to these parameters to justify logically and mathematically the perpetual existence of the process of internal exchange to provide the motive for change. It becomes a dictum to apply this law to any interactive state that continues endlessly and applies to all resonant states of continuous interactions or oscillations or vibrations. The outstanding idea here is that only when the harmony of exchange is derived from within itself can oscillatory activity continue perpetually. The entire manifestation spectrum follows this unique principle with unprecedented accuracy. The Swabhava or self-similar Guna expression is written in two modes to clarify its extraordinary significance:

$$\text{E3} \quad \left( \frac{1}{2} + \frac{x^3}{2} \right) + \left( \frac{1}{2} - \frac{x^3}{2} \right) = 1 \quad \left( \frac{1}{2} + \frac{x^3}{2} \right) - \left( \frac{1}{2} - \frac{x^3}{2} \right) = 0.236068$$

As seen above any interactive oscillation based on self-similar ratios have two limits established axiomatically. The additive sum of 1 ensures that the time cycle is contained. Had that value been larger than 1 the oscillatory state would have decayed and ended the interactive cycle. The difference of 0.236 or  $x^3$  ensures that the cubic damping limit prevents an internal collapse of an oscillatory cycle.

## Secret Of Sankhya: Acme Of Scientific Unification.

All oscillatory cycles are shown to follow this law in Sankhya.

$$\begin{aligned} \text{expansion} &= 1 + x = \frac{1}{x} = 1.61803399 \\ \text{ratio} &= \frac{1}{1 + x} = x = 0.61803399 \\ \text{compression} &= 1 - x = x^2 = 0.38196601 \\ \text{ratio} &= \frac{1 - x}{x} = x = 0.61803399 \\ \text{resonance} &= \frac{1 - x}{1 + x} = x - x^2 = x^3 = 0.23606798 \\ \text{ratio} &= \frac{x - x^2}{1 - x} = 0.61803399 \end{aligned}$$

This extraordinary law based only on cyclic time called Dharma in Sankhya provides perpetual dynamism to the components of space through axiomatic logic described as the three Gunas. The notable point is that the exchange component of the third order is an axiomatic constraining or damping factor existing only in a self-similar interaction.

It is also the difference in cyclic time between two adjacent states. What is a third order damping force? It is simply an axiomatic law of nature that in any instantaneous action there can be only one ratio of all three types of activity in an interaction. That is the act of expansion, compression and resonance must all be defined by one ratio, and can be seen at a glance, as shown:



## Secret Of Sankhya: Acme Of Scientific Unification.

In order to highlight the intellectual excellence of the Sankhyan concept shown above, it is worth comparing with a similar expression in physics that defines the harmonic oscillator, the key to quantum field theory. It is called the Hamiltonian of a classical oscillator:

$$E4 \quad H = \frac{1}{2} \cdot \frac{p^2}{m} + \frac{1}{2} \cdot (m \cdot w^2 \cdot q^2)$$

Explaining,  $p$  = momentum,  $m$  = mass,  $w$  = frequency and  $q$  = co-ordinates, while  $H$  is a quantum of energy. The left part of the equation represent the kinetic energy and the right is the restoring-energy due to motion. It is called the equation of motion. It provides two solutions of  $p$  and  $q$  for a quantum of energy related to mass  $m$ . Ignoring the complexity what the solution gives is the value of the motion **after** the fundamental field of space appears as a reality.

Whereas the Guna expression gives the three phases of interactive motion even **before** the fields appears.

That is, it describes the field of space in its fundamental state of coherent oscillation, like the taut bow in the example. Fig. Above shows the coherent field with varying levels of potential.

It is a static fundamental field in an unmanifest state and remains in a potential state as rings of simultaneous interactive states. The potential state may be seen as released stresses from

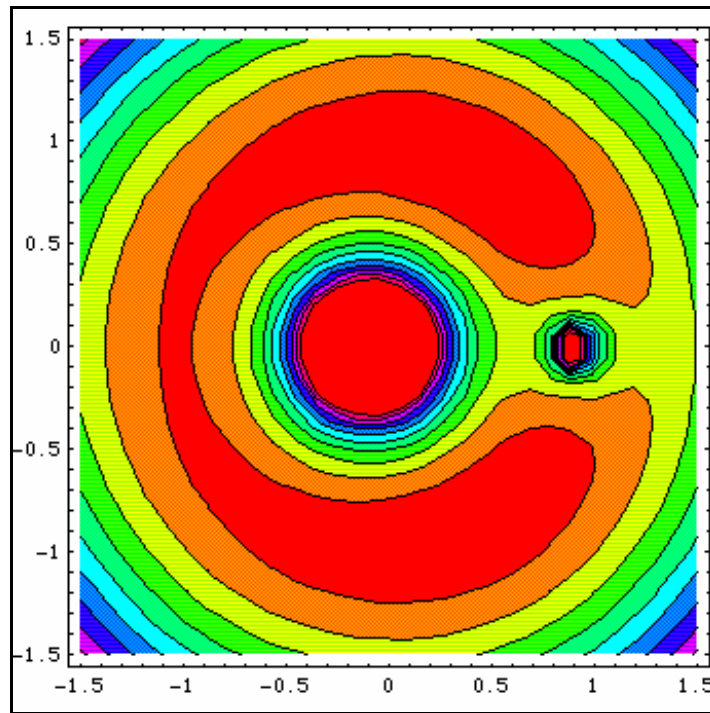

Fig. Concept Of Static Potential Fields.

an interaction and the kinetic state as released stresses in motion displaying velocity characteristics. The Hamiltonian described the quantum of energy after it had started to act whereas the law of Dharma identified the quantum of energy in its fundamental state long before it had started to act. The value so derived endows space with real qualities that physics has yet to discover. The difference in value between the Hamiltonian and Guna values is a massive  $10^{17}$  count unit. Physics with its concepts of mass, momentum and displacement fields has a long climb to reach the conceptual level of Sankhya unless it jettisons these ideas that have relevance only at the laboratory level of desultory experimentation. This emphatic statement is possible only because, in the Suthras that follow, all the universal parameters in its entirety, are derived from those self-similar Guna laws. It is derived

34

## Secret Of Sankhya: Acme Of Scientific Unification.

with unbelievable accuracy, which anyone can verify and find that it goes beyond the boundaries of current knowledge in physics and cosmology.

The axiomatic logic is that if vibrations are caused by interactions then those interactions can only be between objects (whatever these might be) and becomes a dictum. If a theory is to be based on sound logic then the investigator cannot ignore this important fact. Theoretical physics has ignored the vital fact, that elemental space cannot be a vacuum, devoid of identifiable states. Any component with total freedom will move linearly in reaction to a force but a sea of objects with no freedom whatsoever can only vibrate at the same location in response to an impetus with similar elemental objects around it. This axiomatic statement describes the internal interaction between components that follow laws categorised as self similar. It is limited to three Guna states that can be described scientifically as Thaama or inelastic collision, Sathwa or elastic radiant expansion and Raja as resonant or bound states.

Stating it simply, vibrations that remain and add up in the same location is Thaama, while vibrations that keep changing their location and seem to move away is Sathwa. Vibrations that seem to shuttle between these two locations that cannot be described as Thaama or Sathwa is Raja. These interactive vector-tensor states result in numerous permutations and combinations to provide the holographic base. The principle of self-similarity, embodied in the three Gunas, is symbolically represented by a bow. Forces of compression in the inside of the arch matched by the expansive tension on the outside are kept in static equilibrium through the tension in the bow-string that balances all three states simultaneously. When an arrow was shot, it represented a scalar force and what the Schroedinger equation in physics calculated was the depth of penetration in the target. Whereas the Raja concept

35

## Secret Of Sankhya: Acme Of Scientific Unification.

depicted the tension in the string as a stress in the 'dynamic but restful' state before the arrow was shot. The Hamiltonian becomes meaningful only after the arrow is shot but the Guna triad tells one how taut the bowstring is! Because of which, no doubt, that gap in time demanded the principle of uncertainty to be established as an axiom in physics!

The implications of the holographic concept are that every point in the substratum of space contains all the information in the Universe as identical nested sets of vibrations in a frozen form. In essence, it means that every possible phenomenological state exists in every point of space as a locally extractable event. Hence a particular state of interactive phenomenon need not be physically conveyed over a distance but an appropriate set of informative signals can recreate the original phenomenon locally through transmigration of stresses in the connected continuum of space. It can be described as the transmission of interactive stresses at the sub quantum level in physics, where the concept of velocity is replaced by an internal phase change or transmission of phase velocity. In addition, as is well known there is no limiting velocity value for stress propagation in a medium. There is no known law in physics that prohibits a truly rigid rod of infinite length from transmitting a movement, induced at one end, to the other instantly.

As an example a television receiver with its own power supply projects a two dimensional scene when triggered by a signal strength that is a fraction of the power used in system. Similarly, the local 'perpetual oscillators' in space are triggered by quantum level tunneling signals to sustain a three dimensional holographic reality of a particle. Except for one difference, the electro-magnetic signals hop externally across the local oscillators in space, at the velocity of light. Whereas the phase-changes in the three modes of stress tunnel internally across the perpetual

36

## Secret Of Sankhya: Acme Of Scientific Unification.

oscillators in space as transmigratory phase-velocities that has no limit. The components in space act like a solid when accelerated suddenly, like the rigid rod. The components can never be detected directly for they do not 'radiate' but the 'stress-gaps' between components do, as photons. Every 'coherent point' in space has a veritable powerhouse the details of which are dealt with in subsequent sections. The so-called Planckian fluctuations are a result of the resident power in the substratum of space.

The mode of communication of such changes in stress is through a transmigratory, tunnelling process. Such information transmission is virtually instantaneous for it resonantly transfers the change-in-phase of signals through a continuum of dynamic components in the substratum that break the symmetry of the normally coherent state in space. Extremely long wavelengths (ultra low frequency) cause phenomenon that is new to physics. It is dealt with by the principle of simultaneity in Sankhya. Maharishi Kapila theorises and proves through axiomatic mathematics that interactive phenomena in a random and sequential state of inefficient activity naturally transmigrate towards the synchronised, coherent and simultaneous state. A coherent 'restful activity state' can be defined as a 'potential phase' or 'parallel', 'simultaneous', or 'superpositioned' interactive spectrum. It embodies the principle of absorption of non synchronised interactions, like the migration of thermal vibrations from a higher to a lower temperature state. The substratum of cosmic space is truly the ground state.

The concept of simultaneity, not used in physics explicitly, forms a cornerstone in Sankhya. It mathematically defines any group of phenomenon that act together or at the same moment or instant. Logically it seems possible that time-cycle interval between interactive events can be arbitrarily reduced to even 'zero' but does nature behave in that way?

## Secret Of Sankhya: Acme Of Scientific Unification.

Sankhya has shown that there is an axiomatic limiting value of  $1/C^{1+x}$  of a cycle along each axis. Beyond it, the difference in interactive time becomes 'zero' or the two events can be mathematically treated as acting together or simultaneously. The vectorial aspect of a force disappears and it behaves as a scalar. Smaller time-cycle differences cannot be discriminated directly but only through reactions, that radiates a non-synchronised or decaying energy spectrum.

Conceptually man faces a paradox at the very first step he takes to derive the laws of the universe. The two states, static and dynamic, seem to be woven inextricably together. Yet, a choice has to be made if the laws of phenomenon are to be based on a correct foundation. Logical rigour compels one to choose the dynamic state as the elemental or initiating condition. For it's 'opposite' restful, stationery, coherent state is created when all activity simultaneously synchronise into coherence a region, thereby eliminating the duality created by the two terms 'dynamic' and 'static'. Such a static state will represent a passive, frozen blackhole or coherent 'internal' activity and therefore becomes transparent or undetectable. A synchronised state resembles a restful phase; therefore, all active states gravitate towards this coherent condition. It acts as an absorber of vibrating activity or oscillatory movement.

Through this concept, Sankhya exposed the dual nature inherent in detecting phenomenon either as a coherent wave packet identified as a "particle" or an unsynchronised wave ensemble as a "ray or photon" depending on the interactive state of the observer. The inexorable axiomatic logic that leads to this conclusion is that if any two identical components are to remain together as an agglomerate unit then these must be at the same oscillatory activity level. (Like thermal equilibrium / state of relative "rest") Otherwise, every possible

## Secret Of Sankhya: Acme Of Scientific Unification.

combination of vibrating motion causing a deviation must be precisely confined to a cyclic ratio of two. Then it conforms to the standard required to maintain a synchronous and harmonious standing wave.

Had this condition been attained easily there would not have been any detectable phenomenon or an observable Universe today. Hence, there rose a vital need to understand the logic that made it impossible to achieve this coherent balance permanently. Sankhya shows that the conceptual mode of solving this problem is simple, for all one has to do is to create a three dimensional grid divisible by two raised to the  $n^{\text{th}}$  power ( $2^n$ ). However, at the same time it proves it is impossible to achieve the coherent state naturally for the very last or elemental cubic grid cannot be divided. It can only be shared and therefore the last or innermost one keeps each component in a dynamic state of existence forever. The ratio of sharing the elemental cubic grid is axiomatically derived by several principles and quantifies it as 2.718 (the value of the natural logarithm  $e$ ).

It is in the form of a blackhole or Andhatamishra (meaning the darkest division of hell in Sanskrit) which oscillates simultaneously in modes greater than 18 orders of magnitude, as ( $10^{18}$ ) defined in Suthra 48. This shared perpetual activity at the very core, is allegorically compared to the mutually beneficial association of a lame person with a blind one in Suthra 21. The act of sharing is the cause of an astronomical oscillatory super-positioning density build-up that is defined in Suthra 46. It maintains the oscillatory stress energy within it to keep even a Galaxy functioning as a single unit.

In addition, all this complex activity is kept in a perpetually dynamic state only by an extremely gentle interactive rate. It as a constant and consistent boundary activity, which today's cosmology has identified as the enigmatic 2.7 degree Kelvin background microwave radiation. This activity has been compared in Suthra 59 to the genteel

39

## Secret Of Sankhya: Acme Of Scientific Unification.

actions of a dancer, Prakriti (or oscillatory activity) performing before an appreciative audience, the Purusha (coherent blackhole quantum in every point in space). The fact that the observer was aware of phenomenon only through it's vibrations was described as Maya (measured =Ma movement =Ya) in the Vedas, meaning that the observed substantiality of phenomenon is only an illusion like a hologram.

The holographic concept, as a fundamental base for reality, is not recognised theoretically or notionally in physics & cosmology. A special mathematical approach has been made in this translation to make it understandable to the scientific inquirer. Further, an in depth comparison of Einstein's theoretical concepts that led him to evolve the Special and General theories of Relativity, is presented as 'Sankhya & Einstein' in Appendix 2. It highlights its relevance to Sankhya, which provides the very solutions that intellectuals have been seeking for ages. Science depends on the principle of uncertainty to solve problems in the hidden domains whereas Sankhya logic shows that it can be defined certainly and precisely just through axioms

From the foregoing explanation, it can be emphasised that the Sankhya Karika is a purely intellectual creation by Maharishi Kapila. It has been derived by a unique analytical process of yogic meditation that enables the inquirer to understand the functioning of universal phenomenon in the substratum of space. While the observer has no means of experimentally ascertaining nature's true mode of functioning at the elemental level, the intellectual Sankhya way is certainly one complete method that can effectively explain the entire phenomenal process in a theoretically unified way. The axiomatic logic eliminates any arbitrariness in arriving at mathematical solutions which rules out any uncertainty in interpreting phenomenal activity. The Sankhya logic forms a loop starting from past causative interactions leading to events



## Secret Of Sankhya: Acme Of Scientific Unification.

in present time, which points to the conservative reaction in the future. This triangular sequence remains static if activity along the three axes is equal in cyclic time. However, it spirals inwards if the ratio is progressively reduced. Then it ends in a point or singularity. If on the other hand the inequality in ratio progressively increases then the triangular series opens out into a quadratic limit of a square, which is a true description of space.

The intellectual basis for a 'complete theory' compels one to seek a mathematical process that has the quality of being defined as 'natural' or axiomatic. Such a process is transparent and does not need a separate regimen of proof. The range of numerical series available, through simple arithmetical manipulation, are self-evident and the extrapolated outputs are obvious and understandable. Sankhya has shown these concepts are tenable only in a holographic base. Since all human knowledge is a relative process, Sankhya provides a perfectly logical procedure to understand nature through a totally axiomatised and internally derived relational procedure devoid of dimensionality, definitions and postulates. Alternatively, rephrasing it, if man did not know of mathematical subjects like calculus, geometry, trigonometry, algebra etc, how would he then try to understand the process of manifestation? The answer is of course, he will start with elementary counting procedures and that, Maharishi Kapila proved, was more than enough to understand the Universe!

While the common view is that mathematics is logical, it really represents only a sequential relationship of numerical values. Hence, the relative value of the unit reduces asymptotically with increasing numbers, which then makes the unit lose its logical significance. This factor brings in the need to limit the sequence to the numeral two. If the unified laws of physics are truly scale invariant then it must be applicable at the very first change from unit one to two.

## Secret Of Sankhya: Acme Of Scientific Unification.

Moreover, an axiomatic consequence of the foregoing is that there can be no constants of dimensionality, proportionality & linearity if the theory is to be considered perfect. Hence, a change from one to two forms the axiomatic base in Maharishi Kapila's logical derivation and all the laws of physics are miraculously contained in this elementary transition. If there are any true physical constants then it can and must exist at the elemental activity rate of two interactions because at one, the dynamic state is lost and the Universe loses its potential to exist. At levels greater than two, the relative value of the unit progressively is devalued. While  $\frac{1}{2}$  is the maximum ratio of two contiguous numbers, one divided by any other larger numerical value reduces the ratio of  $\frac{1}{2}$  as  $\frac{1}{10}$  or  $\frac{1}{\text{infinity}}$ . This is an axiomatic fact, which Sankhya has used with singular success to build all the Universal laws within the ratio of  $\frac{1}{2}$ . The mathematical procedures needed to operate such a concept are so rigorous and forbidding that there is no possibility of current mathematical methods in theoretical physics ever adopting or even attempting such a process.

Sankhya transcends the need to create complex paradigms and esoteric intellectual disciplines as a precondition to understanding universal phenomenon. Physics today is based on pre-defined postulates, empirical inputs and innovative mathematical techniques, all of which have a built-in caveat –errors of derivational logic and experimental measurement, compounded by the collateral damage in using 'clock-time'. The mathematics involved in describing space in terms of a metric formulation has so many conceptual traps; it certainly cannot be evaluated purely on 'common-sense' or axiomatic logic. The concept of momentum and inertia, from which the principles of physics are derived, is not verifiable except in a laboratory. Whereas Sankhya based on mere counting of observable events or interactions, is a universally understandable

## Secret Of Sankhya: Acme Of Scientific Unification.

concept. It has no caveats as it can be verified both physically and intellectually by anyone, anywhere and at anytime. Above all, it accounts for only one variable – the cyclic time of an event.

It uses a novel and advanced holistic logic, compared to the analytical processes currently followed in scientific investigations, to explain the abstruse theorems composed with two levels of meaning. The obvious meaning refers to the normal living process modelled on similar human attributes and the submerged or hidden aspects refer to the enigmatic substratum of space that is the base for all phenomena. Suthra 69 declares it a secret doctrine, meaning it must be decoded. It functions very logically, with immaculate mathematical perfection, using a simple counting technique, along myriad's of super symmetrical parallel paths that makes it impossible to err, due to the existence of a high simultaneous affirmation factor commonly called redundancy. Further, because it is based on axiomatic logic, the relative limits of interactions can be derived precisely even at the elementary level.

The very first and elementary interaction can be limited axiomatically to counts between two objects. Therefore all the laws of interaction must be contained within this level and in fact, it is shown so. In a holographic base, only the vibratory count in a cycle or period is of significance and therefore transcends the need for dimensionality, while important elementary numerical ratios provide an axiomatic foundation. Though Sankhya numerical values are decimal based, its presentation is confined to indicating the index or power or the logarithmic index value to the base 10. In this book all the numerical values are derived as an integer relationship, but presented as a decimal fraction to enable the reader to easily identify the numerical equivalence with known scientific values.

Einstein abandoned the concept of a cosmological-activity-constant as a logical blunder. On the contrary,

## Secret Of Sankhya: Acme Of Scientific Unification.

Maharishi Kapila had given the equivalence of this important elemental limit the pride of place in Sankhya as the Moolaprakriti (My). It was defined as a fundamental quantum of cyclic time or inertia (or mass). Its value was precisely derived through axioms by defining its limits accurately. The significance of the My value is one of the most important points defining the smallest delay in activity beyond which the concept of motion is reduced axiomatically to a static state. That is, movement involving sequential time changes into simultaneous activity time or the point at which the mass or denser state or inertia is created. It in fact defines the point when dynamic space and static time have the same numerical value in terms of an interactive count. This process showed that in a dynamic state, absolute values have no relevance. Hence, all parameters must be expressed as ratios or rates. The other advantage was that as Sankhya dealt only with cyclic time, any delay meant that inertia or mass became the 'accountable' quantum. Hence My being the smallest possible axiomatic quantum of mass or inertia the whole universe could be described merely by the My count, devoid of dimensional complications.

The evolution of physics has been beset with paradoxes, (see 'Age of the Vedas' in Appendix 1) starting with the Boltzman 'equipartition' theorem. It resulted in deriving a temperature related thermal quantum, the Boltzman's constant. However, it failed on the question of degrees of freedom required in quantifying fundamental activity. Subsequently Planck's quantum theory resolved many enigmatic questions including the cause of the so called ultraviolet catastrophe but its application was strictly limited to phenomenon that was only capable of radiating at least one energy quanta (Planck's constant). Hawking along with Penrose, Schwarzschild and others delved into the frozen region of singularities, paradoxically called blackholes (for Sankhya had labelled it the Andhatamishra

## Secret Of Sankhya: Acme Of Scientific Unification.

state ages ago). They theorised that the phenomenon of super-radiance had the power to create particles but the mathematics depended solely on the ratio of the Boltzman & Planck constants. For as of today there exists no system to directly calculate the interactions within these simultaneous regions of the substratum of space.

The Bose-Einstein or Fermi-Dirac formulations deal only with boundary or interface conditions just outside the stationery or coherent state indicating its degree of rotation or non-synchronisation. In a periodic oscillatory environment, the problem solving Fourier transform series proves to be quite inadequate. It fails to resolve instantaneous transitions of potentials involved in the leading edge of a real square wave (or the region inside the coherent boundary or the 'simultaneous domain)'. Sankhya, despite its apparent origin in antiquity, lays out integer mathematical methods, based on the Guna principle of self-similarity and scale invariance. It provides a precise method to obtain numerical solutions within the "instant" or the enigmatic blackhole domain, through application of the My concept.

The analytical power of its logic is such that it identifies and itemises every component in space as an intensely vibrating holographic phenomenon. It shows that it cyclically ranges internally between a coherent Purusha (Kx) blackhole mass of quarks and nucleonic hadrons with  $10^{18}$  modes of compressive *Thaamasic* interactions. That state is balanced externally by the Prakriti (PM) spectrum of seven levels, as lepton - photon interactive states with  $10^{20}$  counts of expansive Satwic states. Both are bridged by the  $10^{10}$  interactive, intermediate, linking modes of Rajasic activity described as the weak interactive regions in particle physics. When the coherent conditions in the Substratum became unbalanced due to delays caused by a large region of space acting as a coherent unit, then the polarised

45

## Secret Of Sankhya: Acme Of Scientific Unification.

combination of the three Guna activity states results in the ubiquitous gravitational phenomenon.

Contrary to current scientific thinking, the “Strong, Weak and Electromagnetic” forces do not exist as a distinct fundamental property of space in it’s coherent and synchronous state. However, as the delay in regaining the balance grows, the super-positioning of oscillatory counts increase logarithmically. It displays a continuous range of accelerative states right from the boundary of the electromagnetic level to the nuclear core. It follows the same incremental mechanism, which culminates in the gravitational phenomenon, thereby unifying all forces. Any number of waves vibrating at even numbered frequencies maintain their nodal positions in the same relative relationship. Expressing it in another way the midpoint of a spectrum of even numbered vibrations remains in the same position. That is unlike the behaviour of odd numbered oscillations. A rigorous application of the Guna principles, exposes the precise point at which perfect and eternal resonant balance is maintained at the  $K_x / P_x$  (nuclear boundary) interface. Through a remarkable coincidence of an unexpected number of axiomatic ratios, the preceding factors control this boundary. It is the point at which a third order damping constraint based on self-similar mathematics creates the static, inertial, or mass-like states. The confirmation of this unique boundary is confirmed in six different ways through axiomatic mathematics in Sankhya.

An even more surprising conclusion emerges from Sankhya that the circumference to radius ratio  $\pi$  evolves naturally as the loci of increasing rate of interactions following self-similar Guna laws. Self-similar interactions close inward to maintain a centred state at all rates of interactions thereby creating the vorticular particle state. Those that remain stationary due to attaining coherent states are classified as fermion states in physics with half

## Secret Of Sankhya: Acme Of Scientific Unification.

spin and the others with unitary spin values. Sankhya shows through axiomatic logic of two related ratios called Linga & Bhava and Abhiman & Ahankar at the Thaama/Raja and Raja/Sathwa interfaces respectively to produce the phase changes that increase inertial or mass density in several steps. The electromagnetic photon spectrum of waves that form the Satwic region acts in the Ahankar mode, until its Abhiman potential places it in the leptonic particle domain. The crossover into the weak interactive region is conditioned by the synchronisation of interactions along two axis. This superposed state raises the inertia or mass density to shorten the interactive time-cycle and close the spatial distance between particles, which increase its mass. It describes the Raja / Abhiman region of resonant interactions that gradually lead to the Raja / Bhava interactive states Hadron/lepton spectrum. It crosses further into the Linga / Raja resonant spectrum of heavier particulate states. In the Thaama / Linga region is an extensive spectrum of particulate states identified as quark / heavy quark etc. Sankhya shows that in the ultimate coherent state when interactions along all three axis are simultaneous, the blackhole state with 18 orders interactive modes provide the gigantic potential to make these locations into the powerhouse of the universe.

Sankhya logic shows clearly that an increasing rate of vibration in one axial direction, relative to a constant rate in a another axial direction, produces a path of proportionately diminishing displacements, in a confined domain, which sums up to Pi. Putting that in the language of interactions, after this point there are no intermediate vectorial positions but it flip over Therefore nature axiomatically provides particle states with half-spin fermion characteristics inside this boundary. In the Substratum, it consists of a complex, diffused, spectrum of coherent oscillations. It ranges from  $10^{50}$  to  $10^7$  interactions per cyclic period with a precise non-radiant

## Secret Of Sankhya: Acme Of Scientific Unification.

interactive balance maintained at about 4 gigacycles. Cosmology equates that to the Planckian blackbody-thermal-density-spectrum at around 2.7 degrees Kelvin. Sankhyan concept show that the 2.7 Kelvin is actually the value the natural logarithm  $e=2.718$ . If a state is described in terms of elemental interactions as  $N$  then the minimal ratio axiomatically equals  $N$  to  $(N-1)$  and the minimal increment becomes  $1+1/(N-1)$ . The maximum number of ways in which the increment can change is again  $N-1$ . An internally motivated change than can be expressed in terms of the logarithmic value of  $(1 + 1/(N-1))$  raised by  $N-1$ , which equals 2.718 when  $N$  equals infinity. Hence, the rate of internal change can never exceed 2.718.

$$E5 \quad \boxed{\left(\frac{N}{N-1}\right)^{N-1} = \left(1 + \frac{1}{N-1}\right)^{N-1} = 2.718282}$$

Applying the preceding principle the Planck's energy quanta is shown to be relatively larger than the elemental *Moolaprakriti* (My) by 17 orders of magnitude. As the Substratum is always in a quiescent, synchronised and coherent state, it is not externally detectable unless the balance is upset to de-synchronise the coherent state. The proof that the logic is absolutely correct comes from the axiomatically derived numerical values of the following: critical parameters as: Planck mass, nuclear densities, stable nucleon, lepton, proton, photon, Planck-length-time, velocity of light, strong, weak and electromagnetic forces. In other words, there is no need to describe phenomenon in terms of mass, length, time, charge etc but simply by the number of interactions in a cycle. It is the ideal mathematical form that physics has been in search of. In fact, it shows that phenomena can be described purely by a combinatorial algorithm starting from the first interactive count of two. The mathematics is shown in the section on axiomatic derivations.



## Secret Of Sankhya: Acme Of Scientific Unification.

### A Tribute To Maharishi Kapila

A special tribute must be paid to Maharishi Kapila's intellectual excellence. He not only evolved an original, single fundamental principle that unified mathematically all the different disciplines found necessary to understand physics & cosmology, but also established with a simple and exquisite mathematical proof, the most modern, path breaking idea that all manifestation is a holographic phenomenon. He described the substratum of space in Sanskrit as 'Aikaantha-Aathyantha-Atho-Abhavat' or the 'synchronised, permanent, dynamic but unmanifest state'. The Sage has used this important 4 word Sanskrit phrase in a conditional mode in the very first Suthra. While this phrase is not repeated again in the entire treatise, the key words "*aikanthikam – aathyanthikam*" in the ending 68<sup>th</sup> Suthra provide the elliptically terminating proof to logically seal the correctness of the initiating proposition; thereby displaying a reverential attitude towards nature's source of all power, in the true spirit of an intellectual who valued logic and rationality above all else. His impeccable logic and austere style had led his critics to mistakenly label the Sankhyakarika as an atheistic treatise.

The term substratum in this book refers to that important phrase hereafter. Humanity should forever be grateful to Maharishi Kapila for having introduced the concept of a positive intellectual self affirmation process defined as Siddhi in Sanskrit and doubly confirmed its perfection, by laying bare the axiomatic operating principles of phenomenon in just 70 Suthras, with its own internally derived proof, by an extra-ordinary and unequivocal numerical value. By establishing the fact that the observer need only deal with vibratory counts in measuring cyclic phenomenon, he dislodged the concept of clock time that experimental physics now has raised to a position of eminence.

## Secret Of Sankhya: Acme Of Scientific Unification.

Through rigorous logic, time in Sankhya, is shown to be an indicator of a relative delay in the completion of an interactive event. This factor shown is the measure of slackness, flexibility or degree of freedom to move in states that interact in the simultaneous mode, normally described as coherent, synchronised or symmetric space. He must also be credited with deriving a precise mathematical method to deal with simultaneous or instantaneous phenomenon identifying the coherent potential, that eliminates the pain of dividing by “zero” time and has taught man to discover the large spectrum of coherent phenomenon hidden behind the infinitesimal, by mathematically peeping over the zero time barrier. The cyclic period of coherent and symmetric phenomena is symbolically represented by the so called mystic symbol the Swastika which can never turn into a cross for the ultimate Moolaprakriti activity cannot be destroyed. Above all, he has raised the so-called empty vacuum of space to its pivotal and deified role as the source of all power in manifesting phenomenon.

The axiomatic base of Sankhya makes it impossible to be disproved and this quality makes the theory eternally applicable; which fact confers the mantle of divinity to its principles. In this impeccable & logical treatise he has laid out the new and outstanding principle of Simultaneity which accounts for all the past activity that provides the base for all the interactive phenomenon in the relativistic domain of present and future activity. In fact, it provides the vital missing link in the unification regime by evolving the mathematics of a point source or the singularity for completing the equation of conservation that is a must in any field theory. It is the principle that connects the internal source or singularity to the external reaction or fields. Since the law governing simultaneous activity is self-similar and internally generated the ability to correctly predict the state of activity anywhere else is made possible

## Secret Of Sankhya: Acme Of Scientific Unification.

mathematically. In other words distant phenomenon would seem to be connected space-wise apparently violating the principle of causality but in reality since the rules of self similarity are identical every where in fundamental space it can be mistaken for a connection. The Principle of Simultaneity based on axiomatic mathematics is new to science and provides the unifying theoretical base that covers the principles of general & special relativity and the unified axiomatic base for the quantum theory. The Sankhyakarika is indeed incomparable.

The Yoga Suthras of Patanjali are an elaboration of Sankhya Suthra 6, based on the holographic qualities of the Substratum, which hides the limitless spectrum of coherent phenomenon bordering on near magic. Sankhya provides the theoretical base for the Yoga Suthras of Patanjali and in fact, lays out the mathematical definition of the Iswara field, submission to which guarantees the attainment of Samadhi or transcendent mental state of understanding. While the sermonising style of the Bhagavadgita has earned it the reputation of a religious treatise, it is indeed a lay demagogic expose of a complex field theory, of the resonant and dynamic Substratum, entirely based on the 70 verses of the Sankhyakarika. What is more, all the four Vedas, the Brahma Suthras, Vishnu & Shiva Puranas, (among other eminent original Sanskrit works) use the principles derived in Sankhya without trying to re-derive them, thereby acknowledging its principles as being factual and fundamental.

The intelligent and perspicuous investigator of original Vedic creations would understand that the Mahabharatha and Ramayana are a numerically codified holistic three-dimensional dramatised presentation of the Sankhyan holographic field concept enacted by gods, demons and humans representing the ever dynamic and ever interacting forces of nature. In short, it presented the esoteric

51

## Secret Of Sankhya: Acme Of Scientific Unification.

holographic field theory to humanity in a visually understandable and unforgettable way. In the larger sense Maharishi Kapila has exposed the hereto hidden 75 percent of phenomenon in a truly understandable and logical way that should keep humanity busy possibly for the next 1000 years in beneficially learning to use the coherent but submerged power from the Substratum.

The spectrum of innovative coverage is immense; intergalactic-communication by “instant” stress energy transmigration; detection of gravitational potential through phase shift instead of displacement by waves; extraction and transmission of high frequency coherent mega-power from the Substratum by triggered potential changes; triggering coherent states to exchange, compute and control phenomenon at the quantum level using simultaneous modes at unimaginable speeds; the practical use of coherent information phenomenon (currently classified as parapsychological) in plant-animal-human genetic behaviour; psychokinesis, materialisation and teleportation through phase-related coherent holography ; advance or early-warning in micro-event forecasting in genetic behaviour and macro-event predictions in global weather, seismic, tidal and interplanetary activity areas; exploring and communicating with extra terrestrial civilisations virtually instantaneously and much more, where only imagination is the limit. Of immediate interest of the individual would be the possible quantum jump in creative educational methods in all-round personal development. It would take experimental science many decades to fully understand the mechanism of action in the parallel or simultaneous domains of space. The laws of self-similarity, scale invariance, super-symmetry and coherence seem to lay no limits on the manifestation process in the substratum. Since axiomatic derivations lead to defining both the maximum and minimum limits at

52

## Secret Of Sankhya: Acme Of Scientific Unification.

once, any equation has two solutions with reference to both the extremes, which removes uncertainty.

### Compatibility With Science

The question uppermost in the mind of any scientific investigator or reader would be the compatibility of Sankhyan theory with modern physics and cosmology. This factor would have to be doubly emphasised in view of the fact that the tremendous advances in technology today affect almost every aspect of life on this planet in unimaginable ways. How then could Sankhya thought, apparently many thousands of years old, lead the way? Looking dispassionately at the current scientific foundation, one cannot help but see a gap in the conceptual logic of space, reminiscent of reasoning used in mythological stories. The recognised and acknowledged position both mathematically and experimentally today is that space is empty, devoid of qualities and described as a vacuum.

Scientists have been forced into this position because experiments failed to confirm their conjecture of what space should be. Since exotic phenomenon was constantly

## Secret Of Sankhya: Acme Of Scientific Unification.

being discovered, the relentless pressure to use these gainfully drove scientists to substitute mathematical reasoning, that could only explain “how space acts”, instead of “what space is”. Mathematics, being a powerful analytical tool, could even be used to prove the impossible, by deliberately introducing minor lapses in logic and later developing total amnesia about the procedures adopted. Such a procedure called renormalisation is a standard technique in physics. The current dependence purely on mathematical logic is intellectually very unsatisfactory. The relativistic theories of Electromagnetic and Gravitational action depend so heavily on geometry that one is forced to ask if ‘geometrodynamics’ created matter in space that is only a vacuum. In appendix E, a comprehensive review of prevailing relativistic theories is compared with Sankhya logic, to establish the technical superiority of its concepts.

Maharishi Kapila’s derivational logic in Sankhya avoids these intellectual traps. His emphasis that theoretical facts can only be based on axiomatic logic paved the way for him to identify the reality of the structure of space by using the power of axiomatic mathematics to prove that it was so. The spectacular Sankhyan delineation of the entire spectrum of interactions in the medium of space is confirmed by current theoretical and experimental physics only in the observable region. While scientists like Schwarzschild, Penrose, Hawking, Chandrashekhar, Sakharov and Einstein laid down theoretical premises about high-density phenomenon in space, Sankhya has presented its precise mathematical structure with irrefutable axiomatic logic based on the principle of self-similarity. This hidden domain offers physics the real answers to understand all phenomena in space that is certainly not empty. Physicists are aware of an enigmatic and unexplainable interactive state at the Planckian level of space that cannot be justified by current theory. In addition, to make it worse they have even surmised and

54

## Secret Of Sankhya: Acme Of Scientific Unification.

acknowledged that this activity is of intensity far greater than the strong force. Hence, it compelled one to take critical notice of Sankhya because it not only provided an axiomatic theory but also enabled the accurate derivation of every fundamental constant in physics from one basic interaction. As it did not need an empirical input, it was a truly self-generating theory.

General Relativity, though considered an axiomatic derivation, depends critically on the measured values of light-velocity and the gravity constant. Further, Sankhya not only provided an axiomatic explanation for all the important anomalies in physics but also predicted the existence of phenomena for which current theories in science did not have an answer. The ‘Aikaantha-Aathyantha-Atho-Abhaavaath’ state of the Substratum provided the super-symmetry and coherence that physics sought and encountered frequently, especially in ferromagnetism, superconductivity, blackhole and Planckian level phenomenon but were unable to reconcile mathematically with the concept of an empty space. The currently promoted superstring and supergravity concepts in physics, as an answer to fill in the gaps in the unification logic, form an integral part of the Sankhya axiomatic principles. While details of the logic that makes Sankhya a leading theory will be shown later, a striking feature of similarity with the theories of two eminent physicists, Einstein and Maxwell will establish its credentials. Summarising Einstein’s gravitation equation first and then Maxwell’s Electro-magnetic equation schematically:

Einstein:

If variations in geometry of space-time is  $V_{gps}$  then

$V_{gps} = [1] \text{ stress energy} + [2] \text{ mass-energy} + [3] \text{ momentum energy of source.}$

Maxwell:

## Secret Of Sankhya: Acme Of Scientific Unification.

If variations in E and B directions of space is VBEF then  
 $VBEF = [2] \text{ rate of change of E \& B fields} + [3] \text{ change of momentum (current)}$

In Sankhya, the figures in brackets identifies the equivalent areas and unifies it by a single equation:

Cyclic count rate of interactive vibrations in space: -

Unit ratio = [1] Simultaneous counts = [2] resonant counts + [3] radiating counts.

Alternatively, TriGuna mode = [1] Thaamasic counts = [2] Rajasic counts + [3] Satwic counts.

Or interactive mode = [1] Compressive value = [2] resonant coupling value + [3] expansive value

Both Einstein's Vgps (sum of 1+2+3) and Maxwell's VEBF (sum of 2+3) are not true equations for it's solutions lead to an absolute or arbitrary value. The deficiency is even more noticeable when one takes into consideration the fact that the momentum conservative qualities of any field equation must be related to its source. It would be an axiomatic statement to say that any principle of unification leads to the identification of its source. Nowhere in physics is there an axiomatic identification of the mathematical logic or the method of quantifying a source value.

Sankhya has shown that all measurements; detection and recognition of phenomenal interactions are due to a variation in its state of existence. Therefore it leads to an axiomatic statement that measurements must be only due to relative difference and becomes finite when it equals the minimum value of the source. Maxwell showed through mathematical rigour that electromagnetic waves act 'by and

56



## Secret Of Sankhya: Acme Of Scientific Unification.

off themselves unlike sound waves. However, Sankhya logic corrects this view by exposing the undetectable coherent region of simultaneous, self-similar and therefore perpetual activity that makes the source of phenomenon undetectable. When this coherent field of space is accelerated 'instantly', it produces the time varying (non synchronised or non coherent) Maxwell type of cyclic phenomenon of dissipating the energy, stored in the substratum by absorbing decaying activity, as electromagnetic waves. Sankhya mathematics shows that when the coherent state of components in space is broken by non-synchronous or time varying activity, the regaining of coherence is attained by resonant absorption of non-synchronous activity. Such activity is radiated as incremental counts of energy which, sequentially decays back into space, over a period. It leads to an important conclusion that the photon must decay in  $10^{17}$  cycles or seconds in physics. While electromagnetic theory does not lead to this conclusion presently, the enigma of the redshift in the energy spectrum relative to distance (discovered by Hubbles) is an indirect confirmation of the decay. Redshift indicates an increase in potential in the coherent state. The logic of Sankhya clarifies this aspect mathematically through the relevant Suthras.

By applying the Sankhyan principle of Simultaneity, which identifies the axiomatic value of a source, one immediately sees that the fundamental cause of a light or sound wave is identical. Similarly, Einstein's geodesics are 'straightest-curved-paths' in empty space due to the build up of stress or mass due to curvature. In Sankhya logic, all interactions within the cycle 'or instant' are straight-line paths. An interaction must follow a straight path unless influenced by factors that follow an interactive process. Subsequent interactions, due to the continuation of the action-reaction cycle, will vary in time and a sum of such sequential reactions will show the path to be a 'curvature'. In other

## Secret Of Sankhya: Acme Of Scientific Unification.

words, no interaction in this universe ever follows a curved path at any instant. The accelerative sequential interaction in a confined domain follows a curved path. Sankhyan derivation shows that non-coherent interactive displacements always sum up to  $\pi/10$ . It is the comparative ratio of a cyclic interactive period between the linear and radial directions, at any instant. Sankhya self similar logic shows that the axiomatic perpetual activity over the entire past builds up the stress due to obstruction of decaying or dissipating activity. Sankhya avoids logical conundrums by axiomatically showing that any sea of elementary components, whatever it might be, must follow self-similar and scale-invariant laws that will result in the phenomenon we experience. In other words, even a large volume of air or water molecules will follow self-similar laws at locations far removed from other influences. Most important, the act of measurement is a disturbance that breaks the coherent state and hides the self-similar law from the observer.

The Purusha components in space are mathematically definable; precise in action and its vibratory aspect forms the holographically produced states we call matter. Even the velocity of light and the Newtonian gravitational constant, among others, are axiomatically derived through Sankhya Guna principles that show the true theoretical value, which is clearly not the case in current physics. While in physics and cosmology dimensional logic does not provide a selective formulation, in a holographic environment only coherent, synchronous and harmonic phenomenon are observably relevant and provides axiomatic cut-off boundaries. It simply means that there is no need to provide a measured or empirical input into Sankhya to complete the theory. Another important aspect is that an interaction always acts in a straight line along the axis of impact. The subsequent deviations in the reactions and consequent interactions provide the curvature in the

58

## Secret Of Sankhya: Acme Of Scientific Unification.

trajectory. Only intense activity can introduce 'curvature' into space. Sankhya equates the balance of such interactive reactions within the cycle or its simultaneous regime. Therefore the mathematics in Sankhya restricts the analysis to linear processes and factors like  $\pi$  do not form a part of the equations in the simultaneous and resonant states and in that sense it is unlike calculus in physics. The value of  $\pi$  is naturally derived as a cut-off point when outward bound interactions turn inward precisely at the nuclear radius. Beyond it, the interaction flips over to opposite state thereby giving the impression of spin half-fermionic particle. This characteristic behaviour becomes evident only through self-similar mathematics.

The holographic functioning of space and manifestation of phenomenon forms an extremely advanced concept and would take many years of experimental familiarisation for it to gain general scientific acceptance. However, its extraordinary, austere, axiomatic mathematical logic will inexorably compel the mentally flexible and objective intellectual to accept its principles. Maharishi Kapila demonstrated that true axioms cannot be disproved and its validity is eternal which factor provided the strongest intellectual reason to endow science with a divine base. It provided the axiomatic base long sought by physics and unified space into the appropriate substratum needed to complete cosmological theory.

Among many axiomatic statements spelt out in Sankhya, seven of them structured the fundamental state in such away as to make the theory perfect. Maharishi Kapila emphasised that firstly space cannot be 'nothing'. It emphasised the point that a perfect theory cannot be based on an illogical foundation. It introduced the concept of reinforcing ambivalent pedagogic logic with numerical certainty.

Secondly, all phenomena can be described meaningfully, only in a relational mode by comparing like with like

## Secret Of Sankhya: Acme Of Scientific Unification.

qualities. Counting objects or events of the same kind was a simple and certain method of ensuring a relational measure. The sameness of quality could be ensured by reducing a known and ascertained object or activity to its ultimate logical level that established an axiomatic connection with the original quality.

Thirdly, the quality of elementarity or fundamental nature of an object or activity must be derived from within the theory itself through rigorous logic. Confirmation by iterative derivations using several well-established axiomatic parameters would eliminate any uncertainty through a process of redundancy.

Interactions in the fundamental state, far from external influences, can only follow self-similar ratios derived through axioms.

The resonant activities of the manifest state can be equated only with the unmanifest (or hidden) axiomatic quantum or cycle or the simultaneous (singularities) state must equal the sum of the observable (weak & electromagnetic domains) sequential states.

A complete theory must derive all its requirements, as an axiomatic consequence from within itself to maintain its integrity for any error in an externally derived hypothesis can be fatal.

A perfect theory must loop back to provide the qualities of elementary space needed to sustain phenomenon so that its very description provides the proof and nature of its existence.

The question naturally arises as to how these simple axioms can form a basis to reformulate decades of scientific thinking founded on rigorous mathematical concepts that have been refined to unimaginable levels of complexity. As the following three points will show that the foregoing method has been the caveat, Firstly, all languages are only codes built on some adhoc logic that does not have an absolute base of reference. It is a product

## Secret Of Sankhya: Acme Of Scientific Unification.

of the Tower of Babel! Hence understanding any pedagogic communication is a learnt process and the inherent errors make it unsuitable for conveying precision. Sankhya chose axiomatic statements based on relative logic because axiomatic concepts are real for all times.

Being a comparative analysis it had relevance even to studies conducted in the distant future. Secondly, while mathematics in science was built on the precise logic of a numerical unit, communicating complex phenomenon (in real space) through such reasoning lacked an absolute base as it was connected unequivocally to the dimensionality of real events. The validity of an abstract Euclidean geometry in a flat plane had to be supported by the Gaussian concept of closed surfaces plus the Riemannian metric of pseudo-surfaces. All of which followed independent rules but depended absolutely on the logic of a point (a true singularity) which unfortunately had a real 'zero' value in physics. These concepts hide a very serious error. Magnifying 100 fundamental 'points' in a square area into cubes will show that it cannot be divided equally into 50 units along the diagonal. While divisions parallel to the axis will give 50 cubes in each half, the diagonal division will produce unequal lots of 45 and 55 cubes following the expression  $\frac{1}{2}(n^2 + n)$  or  $\frac{1}{2}(n^2 - n)$ . However, the "points" concept would not have highlighted this aspect.

The consequences of this inequality are quite extraordinary. When both axis are in a synchronous resonant state the counts reduce to 10, demonstrating a coherent, static and spherical state. When non-synchronous the count measure rises to a range of entangled counts (vector phases of both axis of 45/55 counts) displaying vectorial characteristics dependant on the relational angle within the cycle time of ten counts. Beyond a ten-count state, the entangled state is broken up and a totally non-synchronous and non-coherent state is established that displays energy radiating characteristics.

## Secret Of Sankhya: Acme Of Scientific Unification.

In a real situation all measurements are a vectorial combination of potential and kinetic factors that makes it necessary to apply the principle of unequal division at the fundamental level. As one can see that with very large numbers the inequality virtually disappears and does not affect the numerical results significantly. The atomic periodic table follows the combinatorial formula stated earlier.

Sankhya axiomatically defined the 'zero' in reality as the Moolaprakriti with an internally derived numerical ratio that matched observed phenomenon perfectly. Since the axiomatic logic matched reality, it provided space with real 'points' that showed it could not be 'empty'. Thirdly, the abstract mathematical concept of clock time in calculus was arbitrarily split into the interval of an instant and its sum as a period. Both of which were applied equally to real phenomenon in space that had built into it three irrefutable and logical aspects of past, present and future time. Logically such an equation was not complete. Sankhya, displaying the height of intellectual clarity placed both space and time on the same footing of it being a non observable parameter, for what man really detected was the completion of an interactive cycle. The repetition of this cycle in three ways gave him an indirect measure of both space and time and its numerous variants as manifestations. Putting it in simple terms, it meant that 'No interactions – No Universe'. Completion of a cycle meant a quantum of both space and time in an interactive state created an observable and sustaining it a phenomenon on a real base. It was a Hologram in short. Vedic description of this state was termed as Maya or measured illusion. Conservation principles demanded the effect of the past be included as a usable parameter, in the simultaneous state. For the source, contained the present plus future parameters, in the weak / resonant interactions and expansive / radiative states of an interactive field.

## Secret Of Sankhya: Acme Of Scientific Unification.

Sankhya mathematics starts with the equation when the instant equals the period as the unified state. The instant is the sum of all interactions in the past and the sum of present / future interactions must equal it. This equation is unique. It identifies the source with a specific relational value that quantifies the  $4\pi$  of the Gaussian field and the  $8\pi$  of Einstein's tensor field and E&B Maxwell fields etc. It leads to scale invariance and self-similarity in interactions that provide the only way to unify all the laws of interactions. Unification demands the identification of the Source and where else would one search for the Source but in the sum of all interactions in the past? Nowhere in current physics or cosmology is there any true equation of state connecting past, present and future that is an indivisible part of the whole cosmic experience.





## Secret Of Sankhya: Acme Of Scientific Unification.

### Simplified View

If the question ‘Can one understand Sankhya easily?’ is asked the answer is “Even a child can but an adult would have to give up his preconceived notions first”. As a simple example, take a cube as a unit object. If it cannot be divided or split, it attains the definition of elementarity. If it can be divided then the first process of division (assuming a limit) leads to a sequence of actions that can be repeated endlessly. If that procedure cannot be changed it can be made into a rule, axiom or law. The cube shown below can be one or more than one.

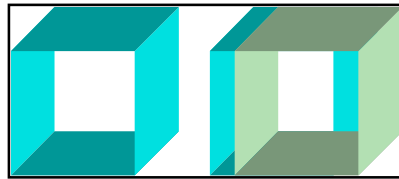

The two cubes below are joined together by glue.

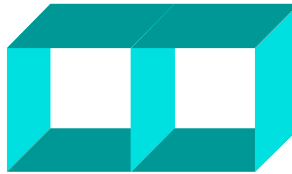

The two cubes below are separated because the glue has allowed it to expand.

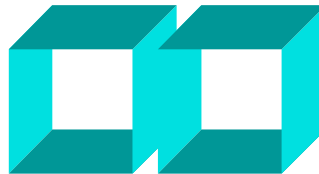

The two cubes below have separated and moved away.



Secret Of Sankhya: Acme Of Scientific Unification.

Taking the single cube as a model, joining it by a glue, then splitting it and further separating it, shows that while the cubes remain the same, only the gaps change. Hence, conceptually the glue here is time. The cubes being elemental and real cannot change but the gap or space can change. Therefore, only time, the glue, must be accounted for in terms of the number of cubes involved. Putting 8 cubes together brings the cubic form back in

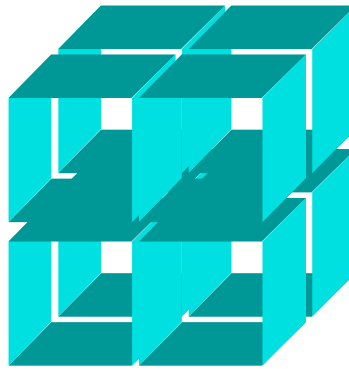

Fig: Elemental Space In Cubic Form

proportion to the original cube. The faces joined or glued are 24 in number. Hence, a formulation can be made that when a cubic form is doubled the 24 faces must be joined by a 'glue'. In principle, whatever activities are involved in the scaling up process must also apply to all such similar expansive operations.

Unit time	$1^2 = 1$	$1 \times 1 = 1$	$1 + 1 = 2$	$1 - 1 = 0$	
Time <sup>2</sup>	$2^2 = 4$	$2 \times 2 = 4$	$2 + 2 = 4$	$2 - 2 = 0$	
		$1 \times 4 = 4$	$1 + 3 = 4$	$1 - 3 = -2$	
Time <sup>3</sup>	$2^3 = 8$	$4 \times 2 = 8$	$4 + 4 = 8$	$4 - 4 = 0$	
		$1 \times 8 = 8$	$3 + 5 = 8$	$3 - 5 = -2$	
			$2 + 6 = 8$	$2 - 6 = -4$	
			$1 + 7 = 8$	$1 - 7 = -6$	
Time <sup>4</sup>	$2^4 = 16$	$8 \times 2 = 16$	$8 + 8 = 16$	$8 - 8 = 0$	
		$4 \times 4 = 16$	$7 + 9 = 16$	$7 - 9 = -2$	
			$1 \times 16 = 16$	$6 + 10 = 16$	$6 - 10 = -4$
				$5 + 11 = 16$	$5 - 11 = -6$

Secret Of Sankhya: Acme Of Scientific Unification.

			4+12=16	4-12=-8
			3+13=16	3-13=-10
			2+14=16	2-14=-12
			1+15=16	1-15=-14

On converting the concept into numbers, the above relationship emerges. Simplifying the ratios eliminates the even numbers and shows only the odd numbers as irreducible or minimal ratios as shown below

Unit time	$1^2 = 1$	$1 \times 1 = 1$	$1+1=2$	$1-1=0$
Time <sup>2</sup>	$2^2 = 4$	$1 \times 1 = 1$ $1 \times 4 = 4$	$1+1=2$ $1+3=4$	$1-1=0$ $1-3=-2$
Time <sup>3</sup>	$2^3 = 8$	$2 \times 1 = 2$ $1 \times 8 = 8$	$1+1=2$ $3+5=8$ $1+3=4$ $1+7=8$	$1-1=0$ $3-5=-2$ $1-3=-2$ $1-7=-6$
Time <sup>4</sup>	$2^4 = 16$	$4 \times 1 = 8$ $1 \times 1 = 1$ $1 \times 16 = 16$	$1+1=2$ $7+9=16$ $3+5=8$ $5+11=16$ $1+3=4$ $3+13=16$ $1+7=8$ $1+15=16$	$1-1=0$ $7-9=-2$ $3-5=-2$ $5-11=-6$ $1-3=-2$ $3-13=-10$ $1-7=-6$ $1-15=-14$

The sequence at time<sup>4</sup> is a repeat of the first sequence as 8 represents the proportionate expansion of 2 to 8 as cubic space. But 16 represents 8+8 or a repeat of the first addition of 1+1=2 and therefore the entire process can be repeated again at a higher level of twice the original level. As time is being accounted for in terms of objects, the unit or count represents an event. Taking all the odd number of events together the total adds up to 1+3+5+7+9=25 and reversing the process to keep it a cyclic event adds another 25. The total then is 50 in a cyclic process. The gluing of 8 cubes showed 24 faces or time events to be counted. The

67

## Secret Of Sankhya: Acme Of Scientific Unification.

one additional event was the common bonding of all 8 corners of the 8 cubes right in the centre. That event was common to all and emerged as a natural outcome of the expansion process of 2 to 8 cubes. The sequence of 25 in both directions gives a cycle of 10 counts as follows.

1	3	5	7	9	=25
9	7	5	3	1	=25
10	10	10	10	10	=50

This simplified structure is explained in detail in the Suthras.

Similarly, if two sticks are used as model a whole sequence of characteristics can be derived. Place two of them end to end and you have doubled the length and initiated the counting process by addition. Take three sticks and place them so that all ends touch and you have not only created a triangle and the seed of geometry too. Intrigued by the closed shape, place another triangle with two sides next to each other and create a diamond shape or a parallelogram. Double this structure again by repeating the last action. Place them in such a way to create a central point. Then one gets four triangles in circular mode. Two more triangles can be fitted to create six triangles in a hexagonal shape. This is a circular shape typical of a cyclic process and the shows possibility of the entire ensemble being moved or shifted by the coherent central point.

So far no particular theoretical knowledge was used in arriving at this stage except a logical and flexible outlook of seeking possibilities, In the process the seeds of arithmetic, geometry and trigonometry, centre of mass characteristics, have been laid. Now the six-sided figure can be halved in each of the six sections to get a twelve-sided figure. Continuing the process of halving each section, till the final part becomes too small to divide further, leads to the concept of deriving  $\pi$  as a transcendental value. Tracing the string of divided sections

## Secret Of Sankhya: Acme Of Scientific Unification.

leads to discovering the infinitesimal rotation, vectors, tensors, Reimann, Gauss and Euclid's geometries etc. Analysing the 12-sided figure yields the possibility of a four-sided figure, a square with right angles. The symmetry of the square in one plane leads to the concept of a cube in three planes or dimension, displaying the true nature of space. A cube can also be viewed as a volume containing some elemental objects with total freedom to move but restricted symmetrically and simultaneously from all six axial directions. If the restriction from all sides loses its simultaneous aspect but is symmetric, a spherical shape becomes evident. If the symmetry too is lost then a random change of, volume comes into play that cannot be defined specifically except for a very short duration.

Space can be packed with elemental cubes without any wasted or adjustable space reproducing a larger cubic space. A cubic box can be packed with eight cubes just by halving along the length in all three directions. Halving each cube in a similar way  $N$  number of times gives  $8^N$  number of cubes. The limit of  $N$  will be reached logically when the side of a cube equals the gap produced by the dividing process. In other words, the length of the original box will be  $N$  times the length of each cube-side plus the gap equals to the former. Then one can describe the original length as  $N$  times 'length of object' and 'gap in space'. The object and gap being equal it can interchange or commute without changing the original length.

If this commuting process is made rapid, the standing wave state of an oscillating mechanism is produced in three-dimensional form that can be accounted for by mere counting in some cyclic measure. Comparing the rate, say along the  $x$ -axis direction with that of the  $y$ -axis indicates two types of phases. It is either a synchronised ratio equal to one or a variation that takes a number of commutations to reach the same count ratio of one. With ratio one along all axes, the commutations or oscillating process reaches a

## Secret Of Sankhya: Acme Of Scientific Unification.

static holographic state. The description of this form is just that of a simple cube, as length cubed or  $L^3$ . However, a complex regime of changeable forms is hidden in this hologram, with a potential, proportional to the number of cubic forms existing in it. In other words, just by intellectual analysis the inquirer finds that he has the ability to 'see' the limitless possibilities of combinations inside the cubic form. It breaks open the shackle of preconceived notions that the human mind has placed on the importance of externalised events, to the point of ignoring internal structures as being of no importance.

This is an axiomatic, transparent and proof-less process that any human being can practice and accept as being logical. One can continue with this process of creating physically 'logical' states to draw meaningful conclusions. If space can be described as being of cubic shape using the smallest possible measuring rod of one fixed size, then all descriptions of, any space can be made by the same process. It is totally dimensionless as an applied dimension in both nominator & denominator cancels out leaving a numerical ratio. If one tries to increase the size of space using the same measuring rod the next size must necessarily be of two units cubed or 8 times the first one. That is 7 cubes have been added by this action. A little mental reflection will show that at the truly elemental level the above conclusion is correct and forms an axiomatic statement. If the rod or cube can be fractionalised then it cannot be called truly elementary.

Now if the operation is reversed, starting with a huge cube, say as big as the Universe, one can reach the elemental size, arrived at earlier, by a number of steps of cubic reduction. The cube so arrived at would seem so insignificant in size in relation to the Universe sized cube that it would logically be termed as a point in space. Today's science viewed the Sankhyan cube as a mere point-in-space and created complex mathematical routines

## Secret Of Sankhya: Acme Of Scientific Unification.

to deal with it. However, Sankhya took the other view and increased the single numerical cubic value to complex levels by mere addition without losing the fundamental relationship. One can immediately see that it is next to impossible to derive simple fundamental laws from a complex level of large numbers with numerous modes of behaviour. However, it is easy to moronically extrapolate a simple correct rule to any higher level of numerical value. This is precisely what Maharishi Kapila has stated as an axiomatic rule in Suthra 23.

One can gain an overall perspective by viewing the Sankhya treatise as an intellectual process of investigation the source of all phenomena. Its importance is enhanced when it is realised that it only involves a simple process of counting stable vibrations, caused by axiomatic states of harmonic balance. Its conceptual uniqueness is confirmed by the lack of prior postulates of any kind, to aid the investigation of fundamental space. The earlier description of mental exploration into a variety of logical possibilities in viewing real space, was in fact a process of drawing hypothetical conclusions. Instead of applying constraints on the intellectual process through arbitrary postulates, Sankhya showed that axioms, being natures postulates, allowed the intellectual process to flow naturally along reasoning processes that the mind felt comfortable with. Mathematics, however complex it may seem, is only a simple process of iterative counting. Proportionality enables scaling up to extremes. When  $1/2$  is a dependable ratio then  $1/2$  raised to the  $n$ th level maintains the proportionality. Compounding such ratios made calculations easier but also made it look complex. Hence Sankhya takes two as ratio and derives all universal parameters to show its inherent simplicity.

Sankhya prescribed a natural mode of thinking because it established with positive proof that there was only one law of interaction that produced all the observable and hidden

## Secret Of Sankhya: Acme Of Scientific Unification.

phenomena in the Universe. The Guna laws, following self-similar principles, operated identically in any fundamental field. The cerebral field too, in its fundamental state had to follow the same Guna laws. Hence, Sankhya laid out an effective process of intellectual analysis and confirmation, through the Siddhi process. The mind followed axiomatic laws in creating interactive mental phenomenon in a meditative state. Sankhya logic was impeccable in arriving at this conclusion.

Maharishi Kapila established all phenomena was of a holographic nature or a frozen ensemble of vibrations in the substratum of space. The human mind too reproduced all phenomena within the cerebral field as a holographic state using the very same Guna laws. In other words, the mind restructured natural phenomenon as mental holograms. It was the most natural process as all phenomena was only a hologram and there was only one law to create such a hologram, the three forms of Gunas. Hence, the Siddhi process of meditative analysis was the most effective way to understand everything.

From it emerges an extremely simplified view of all manifestation, that, if an object is free to move there is only linear motion due to an interaction. However, a component, in a confined plenum or 'sea' of identical ones, can only pass on any motion as vibrations to the adjacent units. Then, only a change, in the rate of cyclic vibrations from a stable resonant ratio of two, is detected as phenomenon. In space stable oscillatory activities, in a state of freedom, are volumetric or three dimensional in nature. Any transition to a non-resonant state must necessarily exceed the two-cubed (8) ratio, which involves an incremental value equivalent to seven volumetric ratios before it becomes an observable. It contributes to the well known spectral qualities of such a quantum.

The gigantic range of phenomenon is due to the variation in the numbers of simultaneous aggregation of vibrations



## Secret Of Sankhya: Acme Of Scientific Unification.

in the substratum, which acts as a continuum. As the process of measurement is one of detecting a change in the rate of vibrations, it takes a time-cycle; hence, it results in measuring it in “cupfuls” as a quantum. While the interaction in space is not quantised but the difference between adjacent states follows the arithmetical series of 1,2,3,6,10,15,21,28,36,45,55 or 0,1,1,2,3,5,8, 13,21,34,55 etc, all of which are dealt with in the main Suthras.

The concept of a field is brought out axiomatically. A unit count of 1 added to another totals to 2. That is two one-counts behave simultaneously. The unit 2 can be cubed to maximise into a cubic form. Reality is cubic and  $2^3 = 8$  are the maximum in that simultaneous state that reflects a real state. Similarly the minimum can be logically shown to be  $2^{1/3} = 1.259921=k$ . Then  $k$  forms that element which related to  $8=k^9$  in the same period and the ratio  $k^8$  becomes the link to the maximum in the simultaneous state. In terms of a field concept  $k$  the movable linear element forms the simultaneous number as  $k^3 = 2 = 8^{1/3}$  in the same instant or the cycle of change at same location. The value  $k^8$  is a simultaneous and  $8-1=7$  the sequential rate of change in this range of counts. Scaling  $2^n$  gives the scale invariant proportionality to any level of numbers. Hence, in Sankhya  $k$  the elemental field state maximises to  $k^9$  instantly or within a cycle.

Any field theory must necessarily be based on a continuum of elemental states in the substratum but interactions in the field take time, so it would seem to be quantised. The quantised value must have some axiomatic relationship to the field in which it is created. While the instantaneous value of an interaction is the product or square of its value, if such interactions take place from all six or orthogonal directions to meet at a point, then its value rises as the sixth power. For simultaneous interactions must be evaluated logarithmically. Taking  $c$  as the value it rises to  $c^2$  on interacting and if such a value interacts towards a point

## Secret Of Sankhya: Acme Of Scientific Unification.

from all the six directions, it becomes  $(c^2)^3 = c^6$ . Alternatively, if a cubic state of  $c^3$  interacts with another such value, it too rises to  $c^6$ . Then the interval can logically be evaluated as  $1/c^6$ , which sets the value of a point in the field. Hence, a point in space can be fixed at  $1/c^6$  as the unit interval that cannot move.

The point in space is an observable that behaves as a simultaneous conglomerate. It is similar in concept to the surface of the sun or earth acting together simultaneously or as a single unit. But the inner or centre of such a unit can be theoretically divided into smaller components. If  $c^6$  taken as an unit be cubed again to reach the final level at  $c^{18}$ , it then defines the axiomatic limit of the core of a point. This sequence can be repeated in the same proportion endlessly but from an observers point of view the 18<sup>th</sup> power gives a stable, definable and final limit to an intellectual excursion into definitions. Similarly, all even numbered interactions result in an even division, which leaves the field in a balanced state. However, odd numbered interactions cannot be divided equally so it remains in the unbalanced interactive state. The sum of all such states is a Catalan or 0.915. Therefore, a ratio of the Catalan and  $c^6$  gives the smallest interval, delay, mass, or inertia. A very fundamental value has been derived by simple logic for the moolaprakrithi. Further, a standingwave is maintained at a oscillating ratio of

It must be realised that while a measuring cup or quanta are being filled it is the interactive process that is filling it. If the time to complete an interaction takes aeons the observer has no means of knowing for he can detect only the completion by the reaction. A major caveat of the holographic concept is that there can be no such thing as a linear velocity or a physical transport of objects in the substratum. Only a transfer of vibratory ensembles, take place at a rate numerically equal to the velocity of light, when there is an obstruction to maintaining the resonant

## Secret Of Sankhya: Acme Of Scientific Unification.

vibratory state. Therefore, at the very fundamental level there are no such discrete things as conventional particles. However, the observer finds it convenient to describe phenomena that exist in stable coherent oscillatory states as if they consisted of protons, electrons, photons, and quarks.

Suthra 62 very succinctly explains that no object or thing is created, bound, released, radiated etc, but only Prakriti (interactive vibrations) in its numerous variations, transmigrate across the identical components of the Substratum as vibratory phenomenon. It clarifies through Suthras 55 to 68 that when the passive but massive Purusha at the core, loses its freedom to remain stress-free, it's slightest deflection to regain freedom, creates the Prakriti avalanche. It transmigrates instantly towards the offending boundary where it attempts to recreate the stress free state of Kaivalya through interactions that may become observable. The axiomatic base shows clearly that such varied factors as the Planck mass / neutron or proton / electron mass ratio, the electromagnetic fields, the structure coupling constants, the quantised charge, the spectral behaviour of strong, weak, EM forces and in general all observable parameters are only due to one process – the vectorial aggregation of vibrations based on purely axiomatic principles that follow self similar and scale invariant laws.

In a colliding interaction, if the action and reaction were instantaneous the compressive stress count would equal the expansive stress value. The instant is defined precisely and axiomatically as the cube of the interval between interactions. The interval between interactions is the product of their individual values. If ten people clapped sequentially, one could count all ten events. If they all clapped together in  $1/10^3$  time interval, the event had to be classified as a simultaneous one. The axiomatic mathematics proved the definition.

## Secret Of Sankhya: Acme Of Scientific Unification.

Reality is truly a holographic phenomenon - for there is no way for any observer to detect the passive Purusha components directly, except through its vibrations! Three dimensional tresses due to interactions either remain as a cohesive, coherent or conglomerate group or seem to be in constant motion otherwise. The former state in a stable resonant configuration get the title of particles etc. Otherwise, the harmonics are labelled as waveforms The simple reason is, in reality; the observer status is conferred only on a collective group of vibrations located on the Purusha! The negative results of the well known Michelson Morley experiments to test the characteristics of ether gives ample confirmation that space is not empty. It substantiates the fact that it is the only result, one can expect when all forms of manifestation are holographic in nature; that is, where only vibrations move on a non moving base! Further, the parameter that the observer measures is merely the change in time and

## Background Of Sankhya

## Secret Of Sankhya: Acme Of Scientific Unification.

The Indian historical background has projected an image that the Suthras are a philosophical composition expressing atheistic principles. Therefore, it invited the conclusion, even from eminent scholars and Acharyas, that it was separate from and inferior to the Vedas. However the earliest available commentary by Gaudapada ascribes the composition to Maharishi Kapila. It described him as the sixth son of Brahma, apparently contradicting the earlier view. However, his views are supported by the fact that Sankhya is specifically quoted as the source of phenomenal field principles in the Bhagavadgita chapter 2 verse 37 as a part of the Mahabharata epic. Despite all the controversial statements, the contents of this purely intellectual creation by Maharishi Kapila is strictly confined to deriving the principles of all manifestation. It defines the very fundamental level of the Substratum and has no religious, sectarian or ideological bias.

In the short human history of scientific investigation, there is no parallel to Sankhya. It must be emphasised that Sankhya not only provides a logical way to find all the missing answers in modern physics but lays out the mathematical principles of super-symmetry of the holographic Substratum to cover every aspect that man may need in the future. The core Suthras provide unequivocal axiomatic numerical solutions to essential questions long posed by the physics fraternity which eminently validates its logic. Hence, it is more than likely that a number of scientific parameters found in Sankhya would be new to physics and cosmology. In any case, the fact that Sankhya enables science to mathematically identify space in specific terms, is indeed a big leap forward, for current physics is based on the postulate that cosmic space is empty.

This book is, in the main, based on the translation by various authors of the straightforward meaning of the Sankhyakarika or Sankhya Yoga by Ishwarkrishna,

## Secret Of Sankhya: Acme Of Scientific Unification.

(commentary by Gaudapada and transliterated by H. H. Wilson and a companion volume “Classical Sankhya”, transliterated and commented by Gerald Larsen). The proving sequel of it’s secret meanings is presented here, apparently for the first time, as an informal dissertation, along with an introduction to the new form of calculative logic of integer mathematics. It was necessary to take this unconventional approach to bring out the true essence of Maharishi Kapila’s treatise in an unequivocal and understandable way, especially when numerous existing translations by erudite intellectuals had already seeded the minds of interested readers with the apparent or obvious import of this extra-ordinary thesis

There are two possible reasons for the ineffectiveness of previous translators in exposing it’s real meaning. The intellectual depth of the Sankhyakarika was grossly misjudged, for the all-important first Suthra seems to have been misunderstood by them. Further, there seems to have been a lacuna in understanding the instructions given in the Suthras on three points. Firstly, according to Suthra 32, the numerical values of activities were logarithms or powers to the base 10. Secondly, groups of Suthras formed complex logical units that could be understood only by treating it as a single structural ensemble through the analytical Siddhi process of Suthra 6. Thirdly, Suthra 69 indicates it to be of a secretive nature implying that special care should be taken in decoding its contents and Suthra 70 specifically indicates the hierarchy of transmission mainly to verify it’s correctness. A detailed analysis of the viewpoints in previous translations is given in appendix D, as ‘Comparison’ along with a copy of the complete translation of 72 Suthras in English depicting the apparent or obvious level of meaning. It is from the published second edition of Gerald Larsen’s Sankhyakarika, and is given for ready reference and comparison, while the present book deals only with the core meaning,

78

## Secret Of Sankhya: Acme Of Scientific Unification.

transmission of which to posterity, was the stated goal in Sankhya.

At some moment in life, man must have wondered about the cause of cosmic phenomenon and the role of human existence in it. The complexity of manifestation must have coloured and confused the result of such musings and conditioned man to readily accept the concept and need for an all powerful, all embracing dynamic creator, of a static but evolving reality, the Universe. The aesthetic thinker, on the other hand, found the dichotomy of substituting the complex but knowable universe with an elegant but unknowable creator, difficult to explain logically, without bringing in further assumptions, again as a precondition. The need for a logically perfect and impeccable solution motivated thinkers to find a natural and easy process that would derive it from within its own background - the human mind. However, the structure and functioning of the Substratum of the mind had to be understood, again, only by logic. Here was a real problem and solving it needed a total or holistic approach. In Sankhya, the principles are for the observer and developed by the observer, the human being. While the process is subjective, it is derived objectively by a system of rigorous logic constructed from the fundamental level as axiomatic principles.

The problem of understanding the Universe, by an observer who is an integral part of it, is like a man who has lost his way, deep in a forest, trying to estimate its depth, so that he could exit by the shortest route. He then seeks the logical mid-point to chart the quickest way out of the mathematical jungle that he has created to represent reality in the abstract. Hence the process of understanding phenomenon must be perfected only by logical thinking and at the same time recognise when the process and solutions are correct, for the process of analytical thinking itself is an integral part of the very phenomenon man is

## Secret Of Sankhya: Acme Of Scientific Unification.

attempting to unravel. Since Sankhya covers the entire spectrum of manifestation, any attempt at isolating it as a set of principles solely applicable to humans (or the living species, as the apparent meaning of the Suthras imply) can result in erroneous conclusions.

The process of communicating any idea is through a code of sounds or script we call a language. (See Appendix 6 for the derivation of Sanskrit). It does not have an absolute base of reference, for it must be learnt by a process of association, and the method of its interpretation, leaves many gaps between what is being communicated and that which is received. Detection, measurement, information, knowledge, language and mathematics are all based on a procedure, for decoding a variation in a common, monotonous, background state. A black dot on a large white background is the start for written language. Clipping a monotonous tone into staccato sounds, form the basis of spoken language. The telegraphic Morse code is just a mixture of short & long sound pips, light flashes or dots & dashes on paper in contrasting colour. On and off electrical pulses, continuous frequencies of electromagnetic waves transmitted with differing mark space ratios or numerous similar variations & modulations in a continuous single frequency transmission, form the basis of computer processing, electronic information, television & radio entertainment systems. Hence, all languages are coded tools of human communication, in which the pedagogical variety has a built in ambiguity whereas mathematical logic provides a higher degree of precision and certainty. Hence, mathematical concepts are essential to maintain precision and necessarily form an integral part of any language of communication.

Monotonous oscillatory states do not constitute information or intelligence but form the necessary dynamic background to become extremely informative if it is varied on some logical, cyclic basis. Again, a continuous



## Secret Of Sankhya: Acme Of Scientific Unification.

interactive state requires a dynamic background to control and sustain it. The intelligent observer will notice the Universe is full of such information provided he learns to decode it. Detection is not possible in a unitary, singular, or cyclic state that causes no difference in a cycle or in communication parlance, the carrier wave must be modulated to make it meaningful. A single frequency state becomes unmanifest or undetectable. It is an absolute, dynamic, background state of something, not nothing. Sankhya lays great emphasis through Suthras 7 to 10, that the activity of vibrations must have a physical or real base and it is totally and utterly illogical to accept that an oscillatory activity can be initiated in empty space. On the contrary, if the observer is unable to detect a cycle of changing vibrations he may erroneously conclude that space is empty and devoid of “objects”.

In this work, reference has been deliberately made to translations of the Sankhya Karika by foreign authors for a very important reason. Indian authors, invariably treated most Sanskrit works and particularly the Vedas, with a great deal of reverence which compelled them to accept unquestioningly the manuscripts recorded from vocalised renderings. The Vedic brahminical process of transferring knowledge through generations depended on using man’s ability to learn, memorise and verbally transfer knowledge and formed the basis of creating “Human books” for posterity. As there are evidence of differences in the transcripts of manuscripts on the same subject, a process of rationalisation has been found necessary to do full justice to its abstruse meanings. The hesitation on the part of our national authors, to re-interpret apparently inconsistent information, has indeed set us back from recovering priceless knowledge from these works. Western translators have guesstimated the age of the Suthras to be concurrent to the rest of the Vedic works and is estimated to be (postglacial) 10000 BC or later.

## Secret Of Sankhya: Acme Of Scientific Unification.

Lokmanya Tilak seems to have been the first Indian intellectual to recognise and openly state that the apparent inconsistencies in the Vedic works had a logical explanation (vide his books “The Arctic home in the Vedas” and “The Orion”). After analysing the geological and climatic anomalies in the Rig Veda, he mathematically deduced the probable period of its origin as being greater than ten thousand years, back in the pre-glacial era, by a civilisation thriving in the polar region which was warm then, due to the uneven variations in the equinoctial precession of the earth’s ecliptic. Along with other geological researchers he had established through archaeological / geological evidence available then, that the historical global inundation, due to the melting of polar glaciers, occurred around 10,000 years ago. The Lokmanya proposed that the complete spectrum of Vedic knowledge had been resurrected in its entirety, after the cataclysmic floods, by following the traditional brahminical method of verbally propagating and aurally recovering information, that was practised by our Vedic forefathers in the pre-glacial period.

In the Atharvaveda, the 28 logical stellar positions (Nakshatra) mentioned in detail enables one to conclusively identify that period 32,000 years ago, by applying the ecliptic precessional rate indicated in it (see appendix B). Deducting 10,000 years for post-glacial recovery, a major portion of the remaining 22,000 years of pre-glacial development must have resulted in an advanced civilisation, judging from our current achievements even within the last 1000 years. The clue to the location of any submerged archaeological evidence of the original civilisation, far below the glacial ice, is given by the identification of the 22<sup>nd</sup>. stellar position, that would have been visible in that period. It would have been somewhere between the 60<sup>th</sup> and 80<sup>th</sup>. Northern-parallel. Only 27 stellar positions are recognised and used currently in Vedic

82

## Secret Of Sankhya: Acme Of Scientific Unification.

astronomical almanacs etc. and seems to be a postglacial correction, this validates the Lokmanya's hypothesis. Consequently, it can be logically concluded that the Sankhyakarika and the Vedas originated from an advanced civilisation, (see note 8) existing in the north polar region during the pre-glacial period and therefore it really belongs to all humanity and not just Indians, Aryans etc.

Even if the concept of an advanced civilisation seems unpalatable to the present insular human race, the unexpected and unexplainable depth of information in Sankhya unequivocally confirms the point of view that it could not have been from the evolving generations within the last 10,000 years. Sanskritologist Max Muller, quoted in his introduction to the translation of the RigVeda, "it is a task for the next century". In another context, he described it, apparently in a state of exasperation, as the "infantile babbling of primitive tribes." Unfortunately, the latter view seems to have prevailed among the western translators with the result the Sankhyakarika has not been given the attention it deserved. Several eminent translators have identified it as the earliest, highly condensed treatise in Sanskrit. Therefore, the meanings of its words and phrases ought to have been developed only by a technique of contextual decoding (especially since Ishwarkrishna gives a strong clue in Suthra 69, by the inclusion of an extremely ambivalent Sanskrit term whose intrinsic meaning borders on hidden or secret concepts in many subtle ways) rather than by applying conventional translation methods under the normal rules of semantics. The failure to realise the need for such a process has left out the secret and hidden meanings contained in Sankhya. In order to help the reader fully understand Sankhya principles, a special lexicon (see appendix 6), created by a technique of statistical verification, gives the current English technical term closest in meaning to the Sanskrit phrases in the context in which it is used in the Suthras.

## Secret Of Sankhya: Acme Of Scientific Unification.

There is considerable evidence that the Vedas are an expansion of Sankhya principles covering the four aspects of understanding phenomenon, namely: from knowledge gained by logical & theoretical principles, established in the Rigveda; by practical identification of key-triggering or initiating methods in the Yajurveda; by a practical system of harmonising or unifying all the required parameters, dealt with in the Samaveda and by the identification of basic materials such as organic and inorganic matter forming the chemical and genetic resources, identified in the Atharvaveda. The four Vedas form a horizontal level grid of equal importance but the brahminical system of vocalised transmission of knowledge to future generations, necessitated a vertical segmentation to make use of the synergistic natural support given by genetic and social backgrounds.

Veda means the science of unification by resonance. Ve is weave or unite and Da is 'that which is given or already exists'. Sanskrit letters also have numerical values, which allows the skilful presentation of a mathematical formula with a related pedagogical meaning. The very first Suthra or Sloka in the Rigveda is a theorem showing the method of extraction of free energy from the Substratum and each letter in it has a sequential numerical value accurate to 25 decimal places that defines the expansive extractable quantum of energy and it's equivalence to currently known values is remarkable (See appendix 6). In the Atharvaveda the very first sloka identifies the starting point scale value for all theoretical calculations in the Substratum, both in descriptive and numerical values and it's uncanny numerical equivalence to Planck's findings is indeed startling (see appendix?).

The subject content of the Sankhyakarika confirms the view of many intellectuals that, all the epics like the Mahabharata, Ramayana and other Puranas, are a dramatised three dimensional live presentation of a field

## Secret Of Sankhya: Acme Of Scientific Unification.

theory representing the super-symmetric and self-organised state of the dynamic Substratum of all phenomenon. Vedic ideology practised under the currently recognised umbrella term of “Hinduism” coined by latter day invaders of India, is indeed a ritualised procedure using the quiescent power in the Substratum to maximum advantage that is not only harmonious but also compatible with long term conservation requirements of the global environment and total energy balance. Vedic ideology was based on the fact that only by acquiring a great depth of knowledge could one gain a high degree of freedom to act but at the same time, it inculcated a tremendous respect for the inviolability of natural or axiomatic law that compelled the beholder to confer on it the mantle of divinity. Sankhya principles show that the unique profusion of genetic life on this planet is due to an extremely fine balance of coherent oscillatory activity at a precise distance from the centre of the our galaxy and the stellar sun. Sankhya re-focuses man’s attention to the reality of universal phenomenon and exhorts him to understand it’s laws, so that he could act correctly and purposefully in consonance with it’s goals and in the process willingly gain the wisdom to see the divinity in its existence.

Briefly, Sankhya and subsequently the Vedas strongly emphasise that reality must be accepted without preconditions, postulates and hypothetical constructs. In this sense, none of the current theories in physics fulfils this criterion. Since the reality of the universal phenomenon has never been in question, it becomes axiomatic to accept the factuality of its foundation and the need to maintain the constancy of its basic contents at the same level, before and after any and all attempts at theoretically explaining its functions. It means that the fundamental contents of a holographic Universe, for example, it’s mass or it’s boundary radius or it’s period of

85

## Secret Of Sankhya: Acme Of Scientific Unification.

existence or other such postulated parameters, cannot be taken into account in generating a theory and therefore any such attempt would be futile as it stands for an absolute and changeless state. Moreover, a perfect and complete theory must avoid the pitfalls of definitions based on arbitrary characteristics and develop its own relational logic that describes phenomenon in relative values of a purely axiomatic nature. The logic is that absolute, open ended, unbounded, limitless conditions cannot be dealt with by mathematics in a precise and meaningful way but can only convey a subjective pedagogical impression of notional limits.

An important aspect of mathematics must be kept in the mind of the investigator that it is only a tool for modelling the behaviour of reality under specified modes and the choice of such a system must yield results naturally which means that the number of inputs and the analytical steps in its process must be a minimum if the conclusions are to have a high degree of certainty. It must not be cumbersome to operate and the process must be easily understandable through a simple logical procedure. Sankhya highlights a caveat in formulating a mathematical approach when dealing with reality at the fundamental level and that is the three dimensional or volumetric aspect of natural phenomenon cannot be excluded or separated in the analytical process. The Sankhya approach overcomes single and two-dimensional analysis by adopting a technique of counting cyclic changes in the vibratory field of the Substratum. Therefore, the description of the Universe is necessarily confined to quantifying its changes as pure ratios based on appropriate axiomatic principles.

The learnt concept of clock time is a subjective one and leads to the imagined instant & eternal polarised concept, similar to the unreal zero & infinite numerical open ended limits. Clock time is not an observable parameter nor is it naturally connected to events that it helps to record for it

## Secret Of Sankhya: Acme Of Scientific Unification.

is an arbitrary human creation. Sankhya concept of time is very clear and unambiguous. In a free and dynamically oscillating environment, any parameter becomes observable or detectable only when it changes from its normal resonant and synchronised state indicating an out of step condition. The important part of this logic is that unless one observes at least one cycle of event it would be impossible to recognise a change. Then the smallest cycle of oscillatory events becomes a natural unit of time in which periodic changes can be represented as a comparative ratio applicable to all levels and the repeatability or cyclic nature is axiomatically connected through the concept of self similarity and scale invariance.

In a resonant and coherent state of monotonous activity the notion of past, present and future becomes one which eliminates the concept of reversibility of a time sequence, until asynchrony sets in, due to internal or external causes. As an example detecting the parameters of a rotating wheel depends entirely on the strobe light frequency, its dwell time and the moment when it's cycle is started and an arbitrary change may indicate a reversal of the true state. In short, if no change can be accounted for then there cannot be any detectable manifestation and having eliminated the absolutes as an influencing parameter, the accountability is limited to phenomenon that can be termed only as "local". This factor brings home an important limitation that non-local or unconnected regions cannot be brought within the ambit of a real equation. Hence, equated solutions, resolving problems of the whole Universe, cannot be real but only locally derived principles can be applied by extrapolation to a finite limit.

In a factual sense the Galactic phenomenon is local and connected, for despite it's diametrical dimension of approximately 200,000 light years it remains a monolithic ensemble acting as a single unit for billions of years. Mathematical concepts applied to reality must produce

## Secret Of Sankhya: Acme Of Scientific Unification.

unequivocal solutions; else, its qualities of precision are lost. Sankhya elucidates in Suthra 30 that in reality simultaneous interactions are multiplicative or logarithmic and sequential reactions are additive. In a field of components in a state of freedom from external influences, at resonance the interactions synchronise along all three axis, to create a relatively coherent or stationery condition that enables the ensemble of vibrations to act as a unit with centre-of-mass characteristics, for axial synchrony aligns the vibrations to fall in step. In such a concept, the ideological division between mass and energy is automatically eliminated because only synchronised or superposed vibrations exhibit mass characteristics. Therefore in a resonant oscillatory state the third power of any rate of vibrations forms a natural damping reaction because it forms a stationery point or the algebraic sum of it's co-ordinate change is zero and provides the limit of a boundary (or a singularity) and eliminates the need to postulate such cut off points.

A plenum or a closely packed sea of fundamental components, in an unhindered state of freedom, far from the influence of its bounded limits must follow laws that are described as self-similar or derived from its own internal background. It is made into an axiomatic rule in Sankhya because naturally obstructed vibrations can only superpose with existing states, the numerical identification of which is a pure axiom and such a series goes under the commonly known name of Fibonnaci numbers. Vector relationship within a cycle are an indicator of a phase change that in reality spell out the degree of superpositioning of vibrations leading to the concept of inertia and mass. In such a situation then there are only three important points that determine the scale of interaction, which are the maximum, minimum and an internal balancing cut-off point that needs to be derived to make the laws work successfully in such a plenum.



## Secret Of Sankhya: Acme Of Scientific Unification.

Therefore, the timing or duration in a cycle must be related to the maximum and minimum rates as a quantised and constant factor to ensure self-similarity and scale invariance. Sankhya principles enable the derivation of a time-cycle quantum that is probably unique to science and proves its validity by its specific numerical association with the “nuclear particle” in its neutral state.

The Swabhava principle of self similarity, (derived in the main text describing the three Gunas) provides a precise numerical method of dealing with such concepts and a positive proof of the existence of a third order damping constraint that induces quantum states is defined. The synchronising or third order coherent point is the instant when the product of the interactive components values equal the sum of the sequentially reactive component numbers within that cycle. It defines the ground or reference state in an environment where everything is in motion. This factor exposes the futility of evolving mathematical techniques to deal with higher number (than 3) of spatial dimensions. Number two has a special significance; the product and sum of 2 are equal; therefore 4 becomes a stable unification numeral and the cube of 2 is 8, which is twice the value of 4 signifying a stable or resonant oscillatory condition. The cube of number 2 = 8 forms a scale-invariant static node which can be raised to any power to deal with other scale levels, using the same fundamental principles and embodies the third order damping reaction that limits and contains phenomenon. ‘Two’ in fact becomes the primary and basic unit that can be dealt with logically at all levels whereas ‘one’ is a mathematically sterile unit because logarithmic or multiplicative operations leave it unchanged unless the principle of dimensionality is introduced. The numeral One is an absolute ratio of infinity upon infinity; hence it forms the natural limit of any comparative process like an equation and is the basis of the conceptually advanced

89

## Secret Of Sankhya: Acme Of Scientific Unification.

form of integer mathematics that Sankhya uses. One or any number can be factorised in two ways to represent reality correctly. The product of factors (multiplicative) represent instantaneous or simultaneous or synchronised values whereas the sum of factors (additive) represent periodic or sequential or time- involved processes. As an example, if nine vibrations occur one after another in a period the rate of oscillation would be one per event that sums up to nine in a period of nine events. However, if the nine vibrations occurred at the same instant the value per event would be nine, summed up over the period and factually represents the logarithmic nature of simultaneous action. The nine simultaneous vibrations form the leading edge of a square wave with a zero time base, which in the current mathematical logic has no true or real solution. If nine people clapped their hands sequentially the observer would be able to count nine individual events but if they clapped simultaneously the one event could be described by  $1 \times 9$  or  $3 \times 3$  as factors without changing its intrinsic value. In an endless chain of moving wagons each unit may contain varying numbers of stored components which are conceptually seen as simultaneous number ensembles of vibrations in transit on each wagon and from a relative point of view it does not matter whether the ensembles move from wagon to wagon or the wagon itself moves. Maharishi Kapila emphasises, through Suthras 7 to 9, that this hidden super-positioning factor has serious ramifications in the physics of the Substratum.

## Secret Of Sankhya: Acme Of Scientific Unification.

### Clarity Of Thought.

Analysing phenomenon logically invariably led to reducing it to its elemental level. Such a procedure succeeded because counting the elemental components distinctively led to an accurate equation of balance. As long as the process involved static or stationary objects, the procedure remained simple and traceable. Activity involved objects that moved or changed location. Accounting for the interval or time period meant, that the concept of accounting for objects had to be changed to measuring elemental states of activity. Hence dealing with a dynamic Universe through a single logical law that integrated time and space as an unit, required an intellectual approach that had not been introduced so far in science. Maharishi Kapila created a unique and brilliant procedure to unify these two seemingly opposing parameters. He considered the cubic solid to be just the form of a vibrating set of parameters that remained in the same location to imitate that permanent shape. Through that approach, the entire set of universal parameters was accurately derived in Sankhya.

The existence of the Universe and all phenomena is confirmed by observation, detection, and measurement. The complete detection process, by either human senses or instrumented methods, depends entirely on vibrations for its transmission and reception. All the human senses, including tactile responses, are motivated only by vibrations and likewise, instrumented results too are conditioned by the same. The key is to understand repetitive oscillatory interactions of the elementary components that cause vibrations. If it is strictly limited to the study of oscillatory functions, then a purely intellectual effort should enable man to construct a basic theory, right from the ground up to its limiting boundary. Such a fundamental theory should enable him to anticipate the

## Secret Of Sankhya: Acme Of Scientific Unification.

entire spectrum of permutations, combinations and its ramifications, that are possible in the dynamic oscillatory state. With this understanding, he could derive the limits, limitations and the conditions necessary for the theory to operate as predicted. He could also identify the critical turning points to be verified in reality, to confirm its theoretical validity. All this is possible because only one parameter, namely vibration, is to be studied analysed and understood. Above all, if this subject was to be understood by everyone then it had to have every supplementary subject or aid to comprehension, built into it.

That is exactly what Maharishi Kapila did in evolving the Sankhya principles, purely by intellectual means, using the human mind as his theoretical and experimental laboratory. The depth of his intellectual acumen can be gauged by his mode of presentation. Since it was to be transmitted orally through vocal statements (see note 4), by young and old through generations, who may or may not have been capable of understanding its technical purpose, two levels of meanings were woven into it. The carefully chosen words had a general, static, everyday meaning, applicable to humans, so that the temptation to give a slant to 'difficult-to-understand' words was eliminated and a metric poetic style encouraged the young to reproduce it faithfully. Additionally, the coherence or unity of a thought process was defined by the poetic Arya metre, like the full stop at the end of a sentence. The hidden real hard core meaning could be extracted by an intellectual and confirmatory Siddhi process of meditation, indicated in Suthra 6. The critical numerical verifiers of important theorems was presented in the guise of an innocuous numerative style as an apparent aid to memory. Every word, number, syllable and economic style of its presentation has a meaning. The proof that the Maharishi succeeded is confirmed by the fact that not only every important constant in physics literally falls out on

92

## Secret Of Sankhya: Acme Of Scientific Unification.

application of its principles, but has provided an impeccable algorithm to identify every unit of scientific value from the Substratum in the future.

The true significance of this work can be brought out more forcefully by comparing a statement historically ascribed to an ancient Greek intellectual, who after evolving the principle of leverage, stated, that with a lever long enough and a place to stand on, he would move the earth. Maharishi Kapila gave the process of evolving the most powerful intellectual lever, the Moolaprakriti, the dimensionless and scale invariant yardstick that would allow any individual to reconstruct the Universe intellectually through just 70 significant Suthras or holistic theorems (see note 9). Authors of the “Concepts of particle physics” ,Gottfried and Weisskopf have posed this excellently thought out question “Can some grand principle – some wondrously elegant set of equations – encompass all of physics ?” and explained what physics seeks is “ an axiomatic basis of austere but compelling force which, when elegantly formulated, leads inexorably to phenomenon that are complex and that were previously inexplicable, or not even anticipated” ..... . There could not have been a better poser, for Sankhya not only fulfils all the criteria sought above but goes one step further, by providing such a numerically perfect answer, as proof, that could be applied to any and every equation man could formulate with reference to the Substratum. Sounding a cautionary note, humanity in general and the specialist in particular, seem to prefer complexity to simplicity, romanticism to reality and the obscure to the obvious, all of which may make difficult the acceptance of Sankhya for what it really is and one can only hope that his innate mental flexibility and inner wisdom is awakened enough to understand and accept its factual clarity in expressing an extremely complex observable phenomenal

93

## Secret Of Sankhya: Acme Of Scientific Unification.

structure that offers the ultimate gift of nature, abundant energy at maximal efficiency.

An important consequence of the Moolaprakriti yardstick is the introduction of six important conceptual mathematical changes (among many others) in current physics that will inexorably compel intellectuals to accept the Sankhya concept of the Substratum of space. Firstly, the holographic state of the undetectable components of the Substratum can be mathematically defined to the required precision for the first time, like the periodic table in chemistry, between both the central nuclear core & bounded limits. It can be presented as a continuous spectrum or continuum, thereby introducing a radical change in our scientific understanding of space. The mathematical formulation, modelled on an algebraic power series, permits even the  $n^{\text{th}}$  level displacements to maintain the coherent and self-similar interactive vibrations permanently in a quiescent stationery state that acts as an absorber or energy sink.

The coherent, super-symmetric, super-conductive, quiescent state is maintained at a precise interactive level by a super heavy coherent blackhole Purusha mass equivalent to  $10^{25}$  GEV or 41 million times heavier than the planck mass and is yet to be identified in particle physics. It forms the immovable ground state. Incidentally, it also provides an ideological solution to the cosmological riddle of an open or closed Universe because of an enormous store of mass energy in a “coherent potential” state. The explicitly defined Sankhya view of the Substratum is that a plenum of components form a base for manifesting phenomenon, like a screen for projecting a movie or a coated television tube that reflects the electronic radiation but with the added difference that the internal state of the components function continuously in a super-symmetric and super-active vibratory mode which when disrupted beyond a precise level leads to a directional

94

## Secret Of Sankhya: Acme Of Scientific Unification.

displacement of oscillations as radiation. In simple words the

Secondly, it proves that the rate of transmission of “control information indicating the state of vibratory stresses” , defined in Sankhya, as transmigration of vibratory power by tunnelling through the Substratum, rises to become “instantaneous” across any conglomerate self contained unit, be it a galaxy or a nucleus, thereby fulfilling the concept of the missing advanced potential necessary to preserve the principle of causality. It means that even a Galactic boundary functions in a ‘simultaneous’ mode as a single entity with a centre of mass characteristics, due to control of it’s inner coherent potential by a mere internal phase shift in it’s coherent state. It has a cascading amplifying effect like a pantograph arm and it’s diametrical distance acts like a rigid rod due to an extremely high compressibility or rigidity modulus caused by an axiomatic collapse function. It is the sum of all past interactions that provides the potential to act. The rigidity is due to an extremely high super-positioning density of vibrations built up by the continuing axiomatic interactive resonant state over an eternity of cycles in a sea of components.

Scientists like Mach, Planck, Maxwell, Schwarzschild, Chandrashekhar, Hawking and Sakharov & Einstein in particular identified the need in principle for a type of metric elasticity or deformation parameter in space and several derivations exist under their respective names. The Sankhya internal rigidity potential under the definition of Abhiman is an extremely elegant axiomatic consequence of applying the self-similar resonant interaction as a summated series in infinite cycle duration. It means that every so called free geodesic of approximately 200,000 light years in space, acts like a rigid rod in which both the ends twist or rotate by the same amount literally at the same time or instantly by the defined Ahankar process.

## Secret Of Sankhya: Acme Of Scientific Unification.

The allowable cycle time for a 360 degree twist is within the range of a single Moolaprakriti cycle. The twist alters the vector potentials along the entire length and is balanced by local corrective action subject to the potential energy state existing there. This factor explains the EPR and the Aharonov – Bom anomalies but more spectacularly the cohesiveness of the Galactic boundary.

No object or wave really moves with a translational velocity that would violate the principles of special relativity but the “instantaneous or simultaneous” change in the direction or phase of interactive stresses causes transmigration of stress-phase-angle at a phenomenal rate, which is obviously a new factor in physics. Viewing the transmigration phenomenon objectively and logically, there should not be any intellectual difficulty in accepting it as it has been occurring in nature from time immemorial, say in the form of sound wave and electrical-magnetic wave transmissions with a velocity difference of approximately million times, analogous to the difference in photon and stress-phase-change transmigration. Hence a disturbance that transmits both a sound and electromagnetic wave independently through a medium, cannot be easily identified as being related, by a later measurement, because of the large velocity difference.

A long rigid rod will transmit to the other end, the same event at different rates depending on whether it is a sound-wave, electro-magnetic wave or a simply by a physical push. Consider a mental experiment wherein the start of a train from a station 300 metres away is signalled electrically in a micro-second, by sound in a second but a “very rigid rod” would transfer both rotary and linear micro movements instantly and will be detected before the other signals. When activity is coherent and synchronised it acts as a rigid ensemble. This experiment indicates both the electrical and sound vibrations are aspects indicating the degree of “non-rigidity” of the rod or medium.



## Secret Of Sankhya: Acme Of Scientific Unification.

Sankhya proves that relative to all the vibratory signals man is or can be aware of, the components of the Substratum form an extremely rigid plenum that rises by 86 orders to reach a super-positioning density level of 96 orders at the moment of a colliding interaction between them.

The fact that a Galactic ensemble can remain together for millions of years demands through logical rigour, the concept of an internal physical connection, for axiomatic mathematics has demolished once and for all the principle of action at a distance or oscillatory activity without a medium. By the same token space cannot maintain an integrated control over units greater than a Galactic ensemble. While relativistic analysis gives all the importance to sequential movement or “time-like” activity within the light-cone, there is no evidence of any explicit method of solving problems in “space-like” regions beyond identifying it as such. The Abhiman / Ahankar factor indicates that distant gravitational potential changes can be detected, only as a local phase change, at an approximate phase related velocity between the 4<sup>th</sup>. and 6<sup>th</sup>. power of light velocity, identified as MohaThaama to AndhaThaama states covering  $10^{18}$  modes of stress-phase-changes and not as a wave in the classical sense. This mode of action is dealt with in physics as entropy, but statistical methods are needed to analyse in detail whereas self similar Guna roles maps this region precisely.

Hence two distant space-like events are related by a signal transmitted by the twist of a “rigid rod” and the rigidity factor conditioned by the stress generated by the density of phenomenon ( matter) in a locality and the maximum stress, is in “flat” or Euclidean space. Such events would seem spontaneous if the internal transmigrating cause is not known. This principle highlights the possibility of detecting distant events, almost instantly, through synchronous-amplification devices that can detect a phase

## Secret Of Sankhya: Acme Of Scientific Unification.

shift / change in the vector potential or gravitational potential of the Substratum. Perpetual seismic activity is a space-like phase related activity caused by other stellar bodies. Apparently cerebral neural systems seem to have this capability in the form of telepathy, clairvoyance and psycho-kinesis, predicted by Sankhyan principles of Yoga and reliably witnessed by scientific investigators, for example, like Puharich of confirmed psychic feats performed by Uri Geller at the Stanford Research Institute.

Thirdly, it proves that all radiated phenomenon, like photons of light, must decay, which consequently removes the foundation for the highly unpalatable “Big Bang” expanding universe concept but at the same time provides a logical mathematical explanation for the distance-proportional red-shift of spectral lines that Hubble discovered. For that was primarily the cause of it’s origin, despite being aware of the fact that this anomaly did not exist within a Galaxy. Since Sankhya specifically recommends integer mathematics as the correct path to understanding phenomenon, the relativistic equations of motion along a geodesic, when transformed through integer mathematical procedures, show that it is a loci of a line of components with a nett zero differential internal-stress-energy-tensor value. It further demonstrates through algebraic mathematics that the infinitesimal displacement identifying the geodesic, itself has a coherent potential that can be expressed in a self-similar and perpetually coherent Moolaprakriti power series by a dimensionless variable, upto infinite levels, which seems to be new to physics.

The gravitational red-shift confirms this concept, which demands the distance proportional behaviour and by the same token it leads to the inexorable conclusion that any cupful of energy called a quanta must wear itself out at some finite distance in a free field. A photon is an accelerated wave packet that has broken out of the

98

## Secret Of Sankhya: Acme Of Scientific Unification.

boundary of the phase synchronised coherent state due to an obstruction that has disrupted the symmetric internal oscillations. Spatial transmigration of stress like an electrical signal, precedes the photon, similar to a sound wave, to tell it when to stop. The photon mass is a Moolaprakriti, excited by a structured ensemble of seven levels of randomly superposed vibrations that wagon-hops along the 'geodesic' components, dropping a count per hop, which allows the first ensemble to last approximately 60 light years. The internal stress level of log 66 axiomatic value dissipates itself at a radius of log 22, being the volume<sup>1/3</sup> proportion of a plane wave..

Fourthly, in a holographic model there is no ideological division of mass and energy, hence even the lightest "particle" must possess the quality of synchronous, centred vibrations or "mass," thereby clarifying its structure. Superpositioned vibrations act as a unit on a supporting base, thereby introducing the concept of inertia in a field. Because of this dichotomy, Einstein was compelled to postulate the principle of Equivalence to explain the seemingly magical quality of mass and force maintaining a constant relationship in a the gravitational field. In a holographic model all manifested "particles", are only superpositioned sets of vibrations in the undetectable Purusha components in the Substratum. Hence all particles of any "mass" must "move" at the same rate like different sized objects move together at the same rate on an escalator and each of its step or landing signifying a different state.

Fifthly, the "coherent and unmanifest massive state" of the dynamic Substratum provides the base for absorbing radiation (decay) through the collapse function that maintains the rigidity of the field, resulting in the principle of spontaneous & continuous creation. The axiomatic collapse function, being a continuous and constant phenomenon, depicting the simultaneous-sum of all

## Secret Of Sankhya: Acme Of Scientific Unification.

previous interactions, caused by any obstruction to a resonant state, enables the Substratum to maintain the coherent super-symmetric state with an abundant reservoir of synchronous mass- energy in an unmanifest or hidden state along any two synchronised axis. The logic is based on the fact that higher vibratory states will always be reduced to the lower state it is in contact with, by equalising, akin to a thermal equilibrium process.

Lastly but of significant importance, the large hidden spectrum of high “mass / energy” phenomenon can be extracted when the perfectly balanced, coherent and super symmetric state of the Substratum is disrupted by high frequency asynchronous triggering. Physical evidence of this process already exists in the form of the enigmatic cosmic ray phenomenon triggered spontaneously by a seemingly random collapse function. Ball-streak-lightening and Polar Auroras are another example. The mechanism of Hawking’s super-radiance phenomenon, being an exact replica of the photon spectrum at the blackhole boundary, gives additional confirmation. Hawking’s blackhole temperature value is derived through Sankhyan logic with extreme precision. The Sankhya mathematics shows that there is a continuous, constant and simultaneous interactions active in  $10^{18}$  parallel modes, that makes the Substratum the most active foundation of the Universe and yet it is not detectable! It opens the door to a new system of environmentally safe, cold and synchronous conversion of large amounts of field energy into either mechanical or electrical work output . See Section ‘Powerhouse of the Universe’ and the ‘Self Charging Battery’ for details.

It is unlike nuclear processes that uses the principle of converting mass potential into kinetic energy through a change in phase or state, which is similar to a fossil fuel cycle that needs a periodic conversion set-up. It requires a natural or manmade procedure to cycle the input fuel so

100

## Secret Of Sankhya: Acme Of Scientific Unification.

that it is capable of sustaining a radioactive interaction. In space the stress energy vector potential is at an astounding  $10^{35}$  Newton's in relative terms. As an illustrative example, the atmospheric air pressure of  $10^5$  Newton's responds with a massive thunderous sound wave lasting several seconds to a near instantaneous lightening trigger. It is indeed an irony of fate that India, the country that revered and preserved this Vedic knowledge intact, has been competing as assiduously as other nations in searching for a viable energy alternative, while it had the key in its keeping, in the form of an ancient heritage.

Many centuries ago Count Magdeburg evacuated air from two very large metal hemispheres placed together and when a number of horses could not pull them apart, he let in air to allow the containers to separate on their own. This experiment was necessary to prove to the scientific community of that period that pressure (force) and vacuum (suction) were not two separate and opposite forces but was due to a single force : the pressure of the dynamic atmospheric air. Since they believed that human lungs would be crushed in an environment in which air exerted a pressure of 14.7 lbs. / sq.in or 10,000 Newton's / sq.M.; they had to be shocked into accepting this currently acknowledged common fact by a dramatic experiment.

The logical lesson from it was profound. The observed force due to a vacuum was only due to the pressure or state of activity of some thing in it namely invisible air, which had inherent potential and kinetic qualities. Sankhyan logic indicates that our current understanding of the basic cause of phenomenon is precisely at the same crossroads and a Magdeburg type of experiment is vital today to establish the true structure of space but unfortunately the size of the sphere needed would turn out to be of sub-atomic dimensions!

## Secret Of Sankhya: Acme Of Scientific Unification.

Hence the Sankhyan intellectual approach to theorising about space was well founded for science had learnt through the Michelson Morley experiments that qualities of the “vacuum of space” were beyond experimental observation. All the current impressive developments in science stands for a horizontal surface thrust but the discovery of new phenomenon in “thousands” gives a misleading impression of progress in depth. Success in a vertical approach (depth) would immediately exposes the current knowledge as belonging to one deck whereas Sankhya proves that seven such decks are needed to complete just one scale level and a cycle covers 7 x 10 scale levels ! That is one magnificent stretch of phenomenon, by any stretch of imagination, be it mathematical or magical! The concept of a dimensionless theory would be intellectually acceptable if all phenomenon were to be strictly presented as a relational parameter. In fact all numbers can be represented as ratios by putting 1 in the denominator without affecting current mathematical parameters. While 1 at higher index levels remain unusable, any parameter set as an equivalent ratio would have meaning.

## Special System Of Proof

The Sankhyan holistic intellectual approach, using rigorous logic as a tool, led to evolving realistic principles in areas beyond observable confirmation like the Substratum of phenomenon. Sankhya endorses the view that mathematics, like any language, is only a structured code and does not automatically ensure the maintenance of logical rigor. Realism demanded the acceptance of the axiom “one cannot detect Nothing”. Having established that in reality, only a change in “Something” can be detected, the basics of a dynamic fundamental state was evolved by a system of mathematics that suited its “starting“ status. Dynamic behaviour at the basic level had to be defined in a simplified but definitive or axiomatic way to eliminate errors of logic, yet it had to be applicable to non-dynamic or static states as well. Similarly the mathematical evolutionary base had to be non-controversial for all times in the future, hence only simple, unambiguous and self-evident axioms, that were outside the boundaries of postulates, preferences, dimensionality, language, interpretations, subjects, disciplines, techniques, culture and civilisation, could be chosen.

In a Universe where every observable is always in a state of change it was absolutely essential to lay the foundation on some constant and predictably changing process whose operating parameters could form the firm, axiomatic, base for mathematical logic. Having established that only a change could be verified, it became essential to develop an axiomatic principle of constancy of change, under fundamental conditions, as a natural course, that would form the dynamic yardstick of logic.

Even more important was the need to find a mathematical logic to sustain the principle of change as a permanent feature and augment it with a constant incremental ratio forming an infinite series, that prevented the activity from

## Secret Of Sankhya: Acme Of Scientific Unification.

dying out. Further, the holistic approach to any theoretical evolution demanded that it must derive its own proof from its internal logic and also identify and declare beforehand at what point the proving sequence was complete or indicate the proof that it has been proved. Applying a modern flow chart concept, any unitary yardstick of logic placed in a minimal sequence of six equations of proof would close the loop in a circular mode and subsequent placements would only repeat the process already covered. Further, the six logical yardsticks placed in a hexagonal form, automatically connected every vertex to the centre by the same unit of logic thereby increasing the six sequential connections to 12, the additional 6 being simultaneous; forming a hexagonal ring with six spokes. This is a concept of positive simultaneous affirmation or the principle of Siddhi (analysis of logical stream of information in a simultaneous mode) in Sanskrit, that an individual can apply to himself to know that his conclusions are correct within the framework of the chosen logic. Perfection in real time control of a functioning system is ensured by the inclusion of redundant or parallel units operating simultaneously but it is a negative use of the foregoing principle, for it moronically repeats the same process and is a trade off obtained by sacrificing efficiency for higher reliability. However, in simultaneous affirmation, which in effect is an incremental form of redundancy, the results of the previous analysis are the inputs to the next sequence that effectively changes the scale of the repetitive process.

In effect it improves the confirmatory process by the power and is therefore highly efficient in exposing deviations as a value magnified by the power. There are similar parallel processes in nature that improves performance many times over by creating a condition called negative resistance that produces an effective avalanche which leads to resonant coherent states like the

104



## Secret Of Sankhya: Acme Of Scientific Unification.

phenomenon of superconductivity, identified as the *Moha-Mahamoha-AndhaThaama Thaamasic* . Sankhya regions. The implications of such a proving process is mind boggling. As each sequence is completed, the investigator finds he has no freedom to deviate from his starting logic but is conditioned by the strict requirement that the next sequence he is yet to formulate, must not only tie up through the same logic, forming a precise valued central link, but above all it must lead him back to his starting premise within the remaining order of power sequence. One is lead to wonder if any modern investigator would accept such a precondition. Sankhya has such a proof based on the principle of “Nyaya”. The proof of the correctness of Sankhya logic is established internally on the same principle by following the self-confirming Siddhi process and is explained in some detail here to show the logical refinement involved in proving an extraordinary thesis beyond all doubt. A logical yardstick  $L$  , signifying the stable and reliable value of a rate of change is laid out as a hexagonal ring of six units but progressively its power index is raised by one so that it forms a sequence from  $L^1$  to  $L^6$ . The six  $L$  units form the spokes that act simultaneously to provide the common value at the centre as shown.

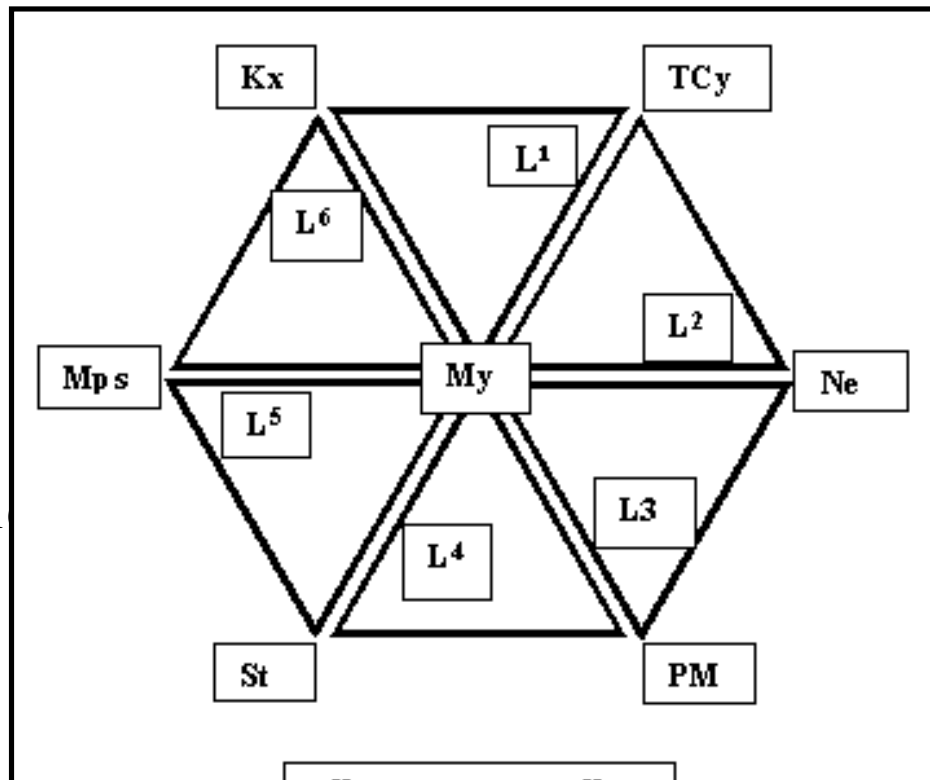

Fig: The Closed Substratum Of Space

The numerical value of derivations following the logical order indicated in the diagram must all be equated to the value at the central point, absolutely accurately. The relevant values of L and C derived in the appropriate sections provide the extraordinary proof that the phenomenon is stable, unified, perpetual and unmanifest or perfectly conserved. My is the smallest and elemental unit-period of activity and L is the maximum number of such interaction or counts per unit cyclic period.

The coherent Purusha state or blackhole of maximum mass or inertia or delay or ‘static’ state per cycle is  $Kx = My (L^6)$ . The next state of increase in activity equals the Planck Mass equivalent of Mahad Prakriti state of  $Mps = My (L^5)/(7+1/7)$ . Thirdly, the state of increase in activity equals the transition activity or the Stress transmigration ratio of 7 states  $St = My (L^4)$ . Fourthly, the stable, neutral and fundamental nuclear state of Prakrithi or the Neutron as  $PM = My (L^3)/Px$ . Here the interlocked Mahad Vikrithi or acclerative state of the Electron as  $Me$  also equals the same  $My (L^3)/Px$ . Fifthly the fundamental particulate state of the Vikrithi or Neutrino as  $Ne = My (L^2) (2 \pi/7)^2$ . Sixthly, the fundamental fraction of a time-cycle of simultaneity when the difference between the static and dynamic state is nil as  $Tcy = My (L)/7$  and equals the Planck time in quantum theory.

## Secret Of Sankhya: Acme Of Scientific Unification.

A cycle in Sankhya is defined through logic as 10 counts. There are three phases of an interaction and two interfaces where the change of phase occurs totaling five in one direction. Another 5 similar phases in the opposite reaction totlas a sequence of ten interactive events in a cycle. The product of such an interaction is  $10 \times 10 = 100$  and the sequence to equalise it is  $50 + 50 = 100$  as a resonant sequential interactive reaction, for any balanced oscillation must cover equal distance in equal times in both directions. It means that  $50 / 100 = 2$  forms a stable oscillatory cycle. Any deviation cannot be less than one count or the ratio of a one count deviation in the total cycle will be as shown ;  $50 / (50 -1) = 50 / 49$ . In order to ensure that an oscillatory state continues,  $L^6$  must reduce to L within one count or a cycle ratio  $50 / 49$  or

$$1+(2/100)^1+(2/100)^2+(2/100)^3+((2/100)^{\text{infinity}} = 1.020408163$$

Then L to  $L^6$  must all equalise in  $50 / (50 -1) = 50 / 49$  cycles to maintain the resonant state. The astronomical rate of power radiation needed to sustain the ratio  $L^6 / (1.020408 -1)$  equals the value derived in physics is  $3.3e+52$ . Further it will be shown that there are still higher rates at smaller cyclic intervals which will be new to physics. If producing

the conditions to suit the above is enough of a challenge it is still inadequate to produce a holographic or dynamically self starting condition. It leads eventually to a stationery or a permanently unmanifest dynamic condition. The series above is exactly equal to  $50/49$  of a cycle in infinite interactions. The unit 1 is likewise integer factorised to produce a complex simultaneous series ( shown in the mathematical section) to represent the six Ls. With these predetermined and internally derived proving tools the, the Substratum described as “Aikaantha-Aathyantha-Atho-107

## Secret Of Sankhya: Acme Of Scientific Unification.

Abhavat” in Sanskrit, is proved to exist permanently beyond a doubt. The critical constants in the special and general theory of relativity are confirmed through the axioms developed in Sankhya and highlights the error that has led to conceptualising space in unreal terms. As shown later in the relevant Suthras, each of the 6 vertices is identified with a precise valued constant like the Moolaprakriti at centre, the constant rate of change  $L$ , the Satwic Bhava or charge at  $L^2$ , the Rajasic Linga/Bhava or electro-magnetic / lepton / boson / hadron region at  $L^3$ , the Bhava Moha Thaama or baryon region at  $L^4$ , the Linga Mahamoha Thaama or quark region at  $L^5$ , the Andha Thaama or the Higgs or Planck mass region at  $L^6$  and the Purusha / Abhiman core or blackhole region at  $L^7$  with a mass around  $10^{25}$  GEV. The Ahankar tunnelling region, new to physics, from  $L^7$  to  $L$  is the vertical potential drop that is balanced by a single Moolaprakriti with an uncertainty of  $50/49$  of the cycle in infinite time sequence as shown by the series above. Each spoke has the corresponding power index signifying the level or rate of transmigration or transmission of vibratory stress within the Substratum. The maximum differential or relative rate is  $L^6$  and the entire simultaneous region of six  $L$  units, forms the coherent, synchronised, resonant, super-symmetric, superconductive, superposed, super dense, simultaneously active, balanced, dynamic, but unmanifest or undetectable state because the interactions are balanced internally. The proof hinges on the sequential factor  $50/49$ , supported by an even more exotic and complex time constant series, shown later, defining the simultaneous  $L$  tunneling states by a single self-similar numerical value raised to any power index level. In the mathematical explanations, it will be shown that all the parameters mentioned above are dimensionless counts numerically equal to values accepted in current physics. Hence it is not surprising that, Maharishi Kapila’s

## Secret Of Sankhya: Acme Of Scientific Unification.

Sankhyakarika is held in high esteem and is specifically mentioned in the Bhagavad Gita, which explains, without mathematics, the functioning of the holographic field in the Substratum, from chapters 13 to 18. It is pertinent to mention here that Einstein (see note 7) raises this very question that the number of equations of proof required to define distances between  $n$  points of Euclidean or flat space is  $((n^2 - n) / 2) - 3n$ , which gives a null or negative result with the value of  $n = 7$  or less. Hence 6 has to be added to this equation to give meaningful results. As shown, the concept of simultaneous affirmation has confirmed that 6 are not only more than enough but completing even these literally becomes a Herculean task. But in Sankhya (see note 10) this task is made into a mere mental counting procedure. Why ?. So that every human being can understand the universal process. It is their right to know and understand a truly democratic process of universal manifestation, if they so desire. It also implies that, with a near universal spread of this knowledge, it must be used with reverence and caution and if misused there is the danger of a similar retaliation by others with similar knowledge. Hence the epitome of Sankhyan thought is that real knowledge leads to total freedom of action, with a real respect for democratic procedures as truth can act as a double-edged sword.

As an example of Sankhya logic and clarity of thought, the development of a simple generic equation for any interaction in the Substratum is shown below. Sankhya does not segregate phenomenon into domains of force. Logically it cannot because only vibrations are involved and the difference in interactive potential can vary from a single count to the sixth power of  $L$  within a cycle. Any volume can be described by length cubed or  $L^3$  and if  $L = V \times T$  (Velocity into time) then  $V^3 \times T^3$  will be the new definition of that quantity  $M = L^3$  whose volumetric form is  $V^3$  and density is  $T^3$ . Again, using a dynamic description,

Secret Of Sankhya: Acme Of Scientific Unification.

R can be defined as a rate of change C into time interval T. Then, in a state of freedom to interact, two sets of polarised factors present themselves for manipulation , keeping N at unity :

$$R^3 = ( C \times T^2 ) \times ( C^2 \times T ) = \text{Volumetric form}$$

$$R^3 = ( C \times \text{superposed interval } T^2 ) \times ( C^2 \times \text{interval } T )$$

Consequently  $M = R^3 \times N^3 = C^3 \times T^3 \times N^3$  . While time T can be measured and has a meaning, the square or cube of time T, must be eliminated as it cannot form a detectable parameter. Re-writing that equation with  $C \times T = R$  as a measurable parameter then the mass  $M = R \times C^2 \times T^2 \times N^3$  . Since the dimensionless ratios, density as N cubed and time as T squared, cannot be measured directly, its product can be written as the constant G in an equation where  $G = T^2 \times N^3$  . C can be measured along any axis so the simultaneous combinations of C along all 3 axis is presented as the cube of C. Rewriting:

$$M = R \times C^2 \times (T^2 \times N^3) = R \times C^2 \times G = R^2 \times (C / T) \times G = T \times C^3 \times G$$

$$\text{Or } M / G = R \times C^2 = R^2 \times (C / T) = T \times C^3 = (R \times C^2 = M \times (1/G))$$

Students of physics will recognise the last as a dimensionless harmonic equation, equivalent to the well known Newtonian gravitational expression (Newtonian gravity constant is Gn)

$$(R v^2 = G_n M) \text{ or } v = \sqrt{\{ (G_n M) / R \}}$$

if the gravity constant Gn is taken as the reciprocal of G and v as C. Sankhya shows that the constant G hides a very large range of simultaneous interactions and the state of the Substratum is shown below. Surprisingly there are no direct equivalent terms in current physics defining the 4 phases within the gravity constant domain and therefore the highly specific Sanskrit term is given instead.

Raja Interactive Oscillatory Cycle  $G = \text{Constant}$

Class of activity	Coherent state	Dynamic state
Substratum state	Yuga	Krama

Secret Of Sankhya: Acme Of Scientific Unification.

External	Abhiman	Ahankar
Internal	Linga	Bhava

The oscillatory rate C remains stable as it is caused by the very first level of increment from one to two as an axiomatic principle. The constancy of C provides the stable ground level that maintains the variable parameters in a proportional and controlled state with reference to it. The foregoing equations can be transposed as follows:

$$M = R \times C^2 \times G = R^2 \times (C / T) \times G = T \times C^3 \times G \text{ and rewriting}$$

$$T \times C^3 = M / (T^2 \times N^3) = (M / G) = L^3 \text{ when } T = 1$$

While this equation expresses the equality of the change on the left side the right side  $L^3$  must be kept constant as it represents the absolute reality, so the constancy is maintained by the hidden parameters in G. In mathematical terms this is a sterile equation because if the right side must not be changed and C is stable then T cannot change. But it is not so. C is the axiomatic rate of vibration in any direction and the total in all three directions is  $C^3$  in a cycle but there is nothing to prevent it synchronising or vibrating simultaneously in step or in phase in all directions, along all 3 axis, at the same rate of C. As an example, if 10 people clapped their hands in a sequence, the 10 events could be counted but if all of them did so simultaneously, at the same instant, then only one event would be registered but with an identifiable difference that the latter would be louder, because the energy content of 9 hidden claps are emitted at once. Hence, when the vibrations along 3 axis synchronise in phase, immediately one understands that an extraordinary event has occurred. The count of  $C^3$  has reduced by synchronising to C along all 3 axis and time T has increased to  $T \times C^2$  so that the right side remains unchanged (though G internally exchanges to equalise by tunneling) and this location now vibrates in the breathing mode and has acquired the quality of mass or synchronous

## Secret Of Sankhya: Acme Of Scientific Unification.

behaviour that amplifies activity. When an unsynchronised rate as high as  $C^3$  drops or collapses to a simultaneous state of  $C$  then the effort to equalise will create a transmigration of higher rates of vibrations towards the  $C$  state (like in attaining thermal equilibrium) but it has now to be in the sequentially extended time  $T \times C^2$  (or equivalently the coherent potential has increased) therefore this state of inward drift remains for a long time. In fact it becomes eternal as shown in Sankhya Suthra 68. The change by increase in measurable count as  $(T \times C^n)$  in the Substratum by mere synchronisation of 2 or 3 axis is shown below:

$$1. t \times c^3 = m / (t^2 \times n^3) = (m / g) .$$

non synchronised state - all 3 axis in free state.

$$2. (t \times c) \times c^2 = m / ((t^2 \times c) \times n^3 / c) = (m / g) .$$

any two axis synchronised.

$$3. (t \times c^2) \times c = m / (((t^2 \times c^2) \times n^3 / c^2) = (m / g) .$$

Here all three axis are synchronised in the coherent breathing mode and energy stored as mass by the absorbed value of  $C^2$ . the  $c^2$  factor in  $g(t^2 \times n^3)$  has tunnelled from observable density  $n^3$  to the hidden superposed domain of time  $t^2$  as  $(t^2 \times c^2) \times n^3 / c^2$ . It is easy to see this transfer in principle but experimentally it can be only detected as a change in the mass / energy relationship with a corresponding change in the coupling or bonding mass / energy ratio. Only an intellectual theoretical analysis will expose the tunnelling aspect.

The important factor to understand is that though all the numerical values remain constant, the mere process of synchronisation leading to coherence brings about a commutation of adjoining factors to produce a spectrum of changed states. The definition of when two sets of vibrations synchronise perfectly is derived through the principle of self similar interaction. The synchronisation point has two well defined constraints. Cyclic time period and the distance in which the same number of vibrations



## Secret Of Sankhya: Acme Of Scientific Unification.

per cycle must be matched precisely, should be derivable as an axiomatic state. Application of the self similar factor  $x = 0.618034$  ensures that the above state is axiomatically sustained and these are derived and proved in their respective Suthras.

The key to this functional behaviour is the equation that balanced incremental or additive time factors. It is matched to the simultaneous or 'instant' incremental ratio and is equal always. That is  $1+x = 1/x$  or  $(1+x)^n = (1/x)^n$ . Regardless of how the vibrations per cycle change, the state of synchronous behaviour as a coherent single unit will be maintained. Hence any cubic, spherical or unit entity can be described in detail, to any levels of accuracy, of its internal interactive behaviour that maintains the unified form or structure. Therefore any nuclear entity, be it the sun or the nucleon, can be mapped into zones of identifiable functional characteristics. The numerical values can be extracted by defining one single parameter that has relevance. Sankhya Sutras define a limit on the previous, past or original state as being cubed. Time cubed cannot be measured but a cubic dynamic state must contain velocity cubed into time squared units in a cyclic time period, both of which are measurable. Through this concept one can derive the time element of a field as the cube root of a detectable value  $N$  and it in turn becomes the field element of  $N$  cubed states.

All this can happen within the Substratum only because vibrations transmigrate through a self-similar law of interaction along the unmanifest components. The change in the self-similar coherent state involves the mere shifting or sliding of the power index in a Pascal triangle of indexed constants terminating at infinity. at has occurred can be explained in many ways. It is the ubiquitous singularity, the gravitational collapse, the black hole, the coherent and kinetic potential interactive gradient, the asymptotic freedom state of quarks, the proton electron

## Secret Of Sankhya: Acme Of Scientific Unification.

boundary unit configuration , the spectrum of electromagnetic phenomenon, the molecular ensemble, the galactic stellar planetary combination, and so on endlessly.

Sankhya describes it picturesquely in Suthra 21 as the association between one who is blind and the other a lame one trying to get out of a deep hole. The integer mathematics formulation shows, without a shadow of doubt that the build up of a coherent state, labelled as a collapse, is the most natural phenomenon in a holographic mode. Any normally self resonant activity will collapse to a coherent state if obstructed.

Thus gravity is born, the root of all forces but it changes its colour during its climb to the boundary in eternal time without changing  $M$  but only its internal state of the constituents of  $G$ . It can occur anywhere and every where, at any place , at any time, but only within the Substratum that functions in a holographic way. In fact it is happening all the time as the quantum fluctuations in the vacuum of space. The change from  $C^3$  to  $C^2$  and  $C$  by synchronising of the axis, provides the three interactive categories of hadronic, bosonic to photonic and leptonic states with similar level-wise characteristics. The largest conglomerate group being a Galaxy to the smallest Moolaprakriti is established as a continuum and all function by the same formulation. All interactive exchanges are described by the same expression regardless of size or cyclic period. The manifested objects are finite and mathematically definable but the Substratum and its duration are beyond any definition because it is an absolute and fundamental state, only with reference to which the entire process of manifestation has meaning.

The answer to the most enigmatic question ‘What is gravity’, being sought so assiduously by researchers, is provided by Sankhya logic. It is caused by a missing interactive count and the count is missed because it

## Secret Of Sankhya: Acme Of Scientific Unification.

synchronises with an adjacent interactive count. A movement of an interactive location (seen as a force) is caused when an equal and opposite reactive interactive state does not arrive at the same point at every cycle of interaction. In real terms the foregoing state is the cause of any movement and becomes a force when a number of units act simultaneously to destroy the balance that two equal interactive states maintain.

The enigma of gravity being a onesided movement or force is explained by the fact that when a large number of interactive states act simultaneously and synchronously a proportionat number of reactive counts to act simultaneously, with the result a gap in the interactive cycle is created. The gap in interactive response creates an inward or “attractive forc”. The phenomenon of inward acceleration is to be seen as spheres or rings of simultaneous interactive states moving towards a ‘mass’ because the reactive response has failed to arrive in time to maintain the balanced location. The aggregative units of interactive states represent a movement of stresses.

The substratum is a continuum but detection takes place only at nodal positions as only integer counts mark the end of the interactive process. Inbetween nodes two parameters will identify any state. There is no uncertainty in the substratum for every interactive event is due to specific cause and locations are bound by laws of cubuc resonance. The most important fact is nothing moves in the substratum but only stresses transmigrate as vibratory ensembles. The solidity is established when the rate of compressive modes exceed  $c^{1+x}$  counts per cycle or a femtosecond . The field becomes continuos and simltaneous transmission of counts increase wavelength. Lower count rate or longwavelength regions act as absorber states. Summarising the above one gets the value of a maximum charge when a  $(c^{1+x})$  synchronised count along two axis splits to lose synchrony and becomes  $(c^{1+x})^2$

115

## Secret Of Sankhya: Acme Of Scientific Unification.

count value as a quantum of charge in motion. Reversing this action by combinng  $(c^{1+x})^2$  to synchronise exactly in phase along two axis makes  $c^{1+x}$  vanish and only so that mass value of  $c^2$  appears as a hidden count because  $(c^x)^2$  being a coherent stress count increase during an interaction it escapes detection but turns up as the reciprocal of the gravitation constant in space to restore an equation with a missing mass value. In other words both mass and charge are momentary or transitory count increases as stress during an interaction and equates the coherent 'restful' state to G as the gravitation constant and quantifies the accelerative increase in stress during an externalised interaction as a charge with a value of E.

Secret Of Sankhya: Acme Of Scientific Unification.

## Secret Of Sankhya: Acme Of Scientific Unification.

### The Missing Count

Sankhya methodically identified all the possible logical reasons for detection and non-detection of events in a dynamic or changing environment (Suthras 5 to 10) and arrived at an important conclusion that in a dynamic system, synchronisation or simultaneous actions ( among many other reasons) hid events and made them undetectable yet the hidden events were accountable. Recall the simultaneous claps episode mentioned earlier. (A similar static analogy would be to view from the top 4 cubes stacked vertically along the y axis and next to it another 4 cubes laid in a horizontal sequence along the x axis.) From a standpoint of correct understanding, the two types of events were identical in totality (10 claps from 10 people), but one had a unitary sequence or Bhava kinetic phase that was time dependant (the cubes along x axis) and the other was simultaneous but number dependant Linga potential phase (the cubes stacked vertical).

Hence a critical observer could arrive at a correct conclusion by measuring, analysing and accounting for the total event, using the three aspects of sequential, simultaneous and an intermediate transition phase that could be a mixture of the two. The concept of detecting simultaneous activity at the basic level was clarified by using integer mathematical procedures. To illustrate, the number of units or objects in equal lengths in the x and y axis (at right angles to each other) cannot be the same, for the item at the intersecting zero position is common to both rows. If sixteen cubes were placed to form a square, 4 would form the base and three rows of 4 cubes each, placed above it would complete the task. Mathematical generalisation results in expressing it as the product of  $4 \times 4 = 16$ , giving an erroneous impression that both length and height have the same number of cubes. Occupancy wise yes but identity wise no, because the first cube in the

Secret Of Sankhya: Acme Of Scientific Unification.

base has been counted again in the vertical length. Since only the state of the cube is cognisable a grave error has crept in by recounting the first one. To clarify, if the horizontal row represented activity proceeding leftward, then if the vertical column stood for an upward move, the first cube shared both these characteristics. Imagine two persons taking a census of two rows of houses on two streets at right angles to each other with one house common to both streets at the junction. Unless they are aware of this common house it is likely to be counted in by both persons. The nature of the error is in the simultaneous representation on one cube, for the sequential counts along both the vertical and horizontal directions tally.

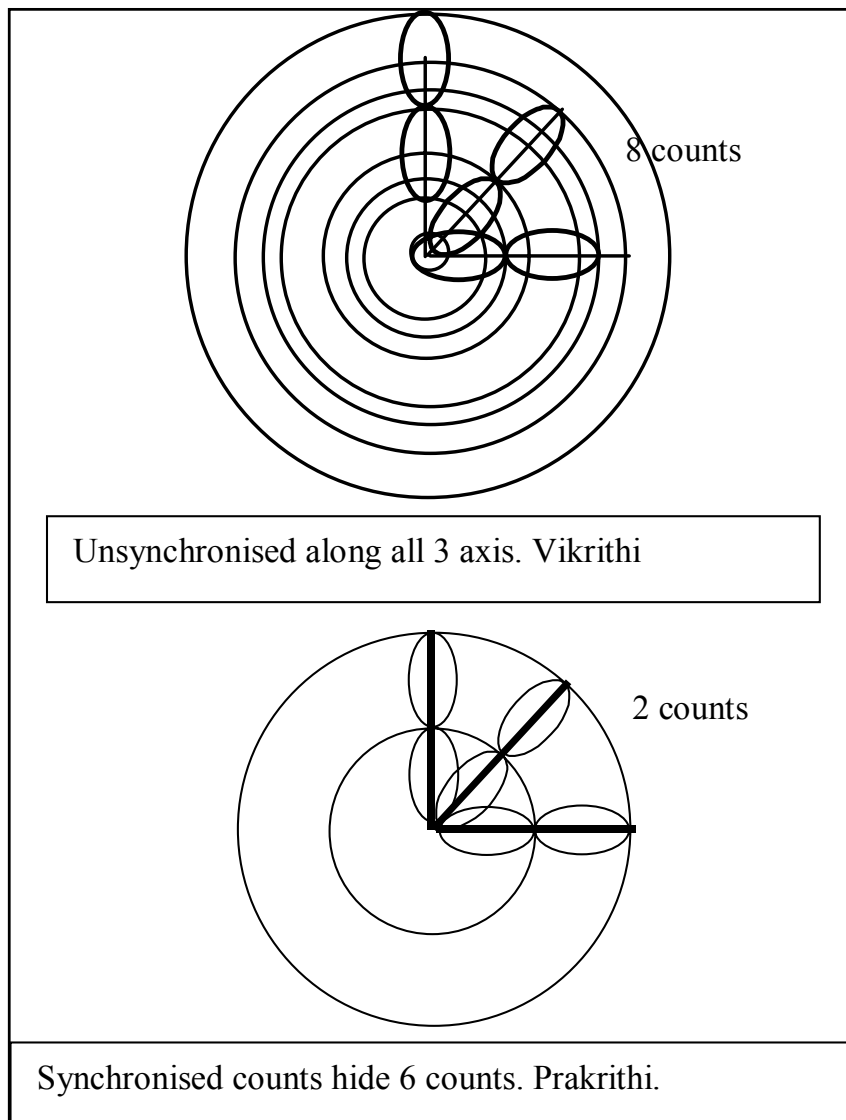

## Secret Of Sankhya: Acme Of Scientific Unification.

### Fig: Concept Of Vanishing Counts

The error was in accounting for the potential phase. It must be realised that in a stack of 4 cubes (two on two) the gradient of change is one by two and not two by two as would be presented in a static framework. Sankhya shows that this potential difference amounts to 50 percent of the total and added to the fact that the two axis, in any interaction do not present equal units in equal times, keeps the state of the substratum dynamic at all times. There, due to the shared functioning of the central cube in all three directions, vibrations can never synchronise or attain a state of rest, internally, at the basic nodal level. The instantaneous activity level at this node called Andhatamisrah or “darkest division of hell”, has a coherent mass equivalent of  $10^{25}$  GEV. Moreover, as there is no limit to the number of vibrations that can superpose on a component of space, any such error can throw an equation totally out of balance.

Since only a change in oscillations are detectable, there is a caveat in differentiating units or conglomerate groups. Even if there are many objects, if all them present the same count rate, the observer has no way of identifying the individual units due to the camouflaging effect or zero contrast status. The problem is exacerbated when accounting for time. Timing is count dependant. Counting 10 interactions in a cycle is accountable. The ratio of 1/10 of cycle time into 10 cycles is balanced. But if each of the ten counts hid 10 more counts as exactly synchronised actions, the process of accounting for time hides a serious error. The 100 counts received as ten counts/ per cycle indicates that that each count takes 1/100 of cycle but  
120



## Secret Of Sankhya: Acme Of Scientific Unification.

that assumption would be highly inaccurate. For it hides the fact that between two counts there was a clear interval of  $1/10$  of a cycle. The former assumption indicates a crowded sequence of interactive events

whereas the events were separated by inactive intervals. This error in derivation of time has given an erroneous impression of

the smallest time interval. The Plancktime does not exist nor can it exist because the smallest interval in time is the Compton interval or  $1/(5e+13)$  of a cycle or second. When all three axis synchronise then the cube of  $(1/5e+13)^3 = 1/1.25e+41$  is shown as the Planckian interval. But that does not exist for the nuclear diameter is the smallest and detectable dimension which allows an interval of only  $(k-1)/(5e+13)$  as the discriminatable unit.

Analysing the information mathematically from the source that sent 10 simultaneous counts with each detectable count will expose the interval as  $1/100$ . But observation or measurement will indicate the blank periods between counts as being one tenth. The counts have vanished but the density remains. Two factors here help absorption of counts. Ten counts will be moving towards 1 count interval and the density being 10 times the time of reaction too will be reduced proportionately. Hence the higher counts can transmigrate to the low count region easily. Hence space is an absorber of counts.

Two objects with two different rates cannot stay adjacent to each other unless there is a common or equilibrium rate at this junction. Similarly higher rates of vibrations will modulate the lower rate and create numerable median or harmonic states or the higher rates will move towards the lower one. Therefore an axiomatic ground state must be identified as the normal background to relate all phenomenon in a meaningful way. The first component can be differentiated from another only by the difference

## Secret Of Sankhya: Acme Of Scientific Unification.

in its count rate. A count of one (or a set) can be recognised only against the next sequence of 2, forming a total of 3. Three cubes can be placed in the x and y axis forming equal lengths but the 1 and 2 difference can be created only by viewing it as a right triangle with a base of 2 and a relative incremental height of 1 forming a hypotenuse of value  $\sqrt{5}$ .

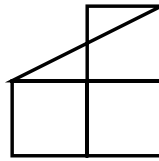

The fundamental nature of this representation is understood by seeing that if all three cubes are at the same level or in a line the count rate does not change and can only be one as the height or potential is same but the simultaneous occupancy or superpositioning density has increased.

Within the instant or cycle this ratio must be treated logarithmically. The variation from a count rate of 1 to 2 is the very first change possible and all rules of interaction must begin from this axiomatic base. Sankhya logic shows that if this 1 to 2 oscillatory ratio of change is maintained, a coherent or stationary interactive relationship is sustained. If the ratio reduces, the oscillatory interactions superpose showing compressive or aggregative qualities; if otherwise separation takes place, exhibiting movement and expansion. The logic of the entire range of phenomenon in the substratum has been constructed from this dynamic base as an unbroken stretch of complex numerical constants forming a continuum.

Accountable three dimensional space could be described logically, symmetrically and economically, only by a cube and the concept of accountability demanded that the fundamental unit retain this continuity at the elemental level. Hence the infinitesimal, point-like unit could not be

## Secret Of Sankhya: Acme Of Scientific Unification.

conceived of as anything other than a cube. It becomes an axiom if it is understood that any other shape requires a derived coefficient to equate it to a cube. Therefore, there is no escape from the unequivocal conclusion that if any section of real space is to be accounted for mathematically, even for an instant, by the ultimate elemental unit, be it the point, infinitesimal, component, particle or whatever, only the cube perfectly satisfies the prime condition required for the title of elementarity meaning that it cannot be any thing other than a single category. (Any gaps between shapes other than cubes must be justified by another quality, bringing in its wake constants of dimensionality.) If it is realised the concept of a point in geometry and the infinitesimal in calculus, hides this logic, then it would at once be evident that both could hide an entire universe of vibratory phenomenon, because an oscillation is not a “thing” but only the “activity count on or in a thing” and if all the vibrations act in unison it is impossible to detect the occupation numbers by direct measurement. From the foregoing it becomes amply clear that the current conceptual base of the entire mathematical structure cannot be meaningfully applied to the hidden simultaneous, coherent, symmetric, dynamic and unmanifest nature of a holographic model of space not because the formulations are defective; it is far from that. In fact logically the current spectrum of mathematics is perfect in the extreme but it can apply only to detectable phenomenon that has a sequential logic, velocity characteristics with at least an instant of the human fiction called clock time. It is well known that the detectable dynamic nature of oscillatory vector, scalar and spinor fields, including the electro-magnetic spectrum, disappear or vanish in the so called “stationery” states. To quote a significant statement from Einstein’s book “The Meaning Of Relativity” in explaining conservative qualities of the field he states “It is interesting that according to the

## Secret Of Sankhya: Acme Of Scientific Unification.

equations ( energy conservation equations) the density of the energy currents (  $a_1, a_2, a_3$  ) as well as the energy density ( $a_4$ ) vanish for a field that is independent of  $x^4$  (=time/velocity co-ordinate) . From this one can conclude that according to this theory a stationery field free from singularities can never represent a mass different from zero.” In the Sankhya mathematical section it will be shown to the contrary that only the stationery field can have the maximum mass in the form of a coherent potential. ( $L^p \times D^p$ ) for the insignificant point in the field is indeed a singularity represented by the elemental cube, the Purusha. This caveat had been precipitated in physics by the failure of the Michelson Morley experiments to detect space as a substantial medium, which drove the relativistic ideology to adopt the notion of a field devoid of substance but endowed with compensatory features labelled as “geometro-dynamics” using the concepts of Reimann, Gauss and Euclid, leading to an abstract form of tensor mathematics. The dependence on an independent field concept brought in problems of singularities that needed arbitrary postulation of boundary conditions that robbed the theory of the ‘perfect’ status. The reality of the quantum phenomenon did not tie up with the field mathematics and drove the wedge deeper and away from the goal of unification. Logically space seemed and behaved as a continuum or plenum but the quantum phenomenon posed the need to introduce a mathematical volte-face towards a purely algebraic theory which did not seem to exist. In this background, the Sankhyan concepts do give a deeper understanding, to solve the type of problems outlined above, by the physics community.

Maharishi Kapila has emphasised the dual nature of the intellectual analytical process and Suthra 5 defines the entire procedure, exactly as what must have been followed by all the intellectual stalwarts in recent times like Newton, Maxwell, Gauss, Reimann, Planck, Einstein,

124

## Secret Of Sankhya: Acme Of Scientific Unification.

Bose, Hawkins, Penrose and many others. It is based on an open ended sequential analytical process, commonly referred to as a left brain dominant approach, that depends heavily on a parallel confirmation from other sources, which again could be based on reliable theoretical and experimental experience of other trustworthy intellectuals using the same logical approach. When an investigator finds that the sequential inferential analytical process is insufficient, when researching the hidden, submerged, eclipsed, occulted, camouflaged aspects of simultaneous phenomenon, he can develop a parallel, simultaneous, synchronised or holistic technique commonly referred to as a right brain dominant approach, that allows him to actually mentally experience it as a real activity giving a self confirmatory internal solution.

One can raise a point of issue by stating that instrumented visual displays of complex phenomenon can do the same thing. It is not so for two reasons. Firstly, a real physical or mental human experience that is conditioned by all the senses simultaneously cannot be reproduced in its totality by any artificial or synthesised effort. Secondly, instrumented live or synthesised creation of complex phenomenon is necessarily based on a deep prior mathematical knowledge of that class of event, to make it understandable and reproducible. Suthra 6 defines such internal confirmatory experiences as a Siddhi and a detailed explanation of the process is given in appendix H that elucidates the reason for its success. At the fundamental level, all human experience is indeed a mental process. The old adage that a picture is worth a thousand words can be extended to mean that a realistic mental experience is worth a million pictures. If there is a doubt about its efficacy, it would become very clear if one accepts that a realistic phenomenon is a holographic event on a macro scale then the cerebral creation becomes an identical resonant oscillatory reproduction on a micro scale. This

125

## Secret Of Sankhya: Acme Of Scientific Unification.

resonant mode of transfer covers the spectrum of hidden-coherent phenomenon like telepathy, clairvoyance, precognition etc..

The old gramophone reproduced the entire range of orchestral music merely through the focused point of a needle. As a quick example, 12 witnesses surrounding an accident site will give 12 sequential accounts of the incident, based on each individual's location, to a judge for a decision. After listening to them, he mentally sees the "instant" of the accident by analysing those 12 statements through a simultaneous intellectual cognitive process of juxtaposing their corroborative statements. While the judge may not have witnessed the accident, his mental analysis of the cross correspondence of the statements of twelve witnesses in the 'simultaneous' mode would provide him with the proving connections to enable him to actually "see" the event in his mind. Whereas the actual witnesses would never mentally get "the birds eye view" of the event as the judge did, for they would have been mentally conditioned by the position from which they physically saw the accident as a sequence and the important fact that witnessing of an event from one location automatically excluded them from witnessing from other locations at the same moment. To mentally see the event as the judge did they must follow the process that he had experienced.

This mode of search for truth has been demonstrated, verified and attested innumerable times by philosophers, saints, mystics, clairvoyants and others endowed with a natural right brain dominated para-psychological aptitude. Only in a holographic Substratum could the cerebral vibrations resonate in synchrony with itself to faithfully reproduce an instant of its reality. Just as electromagnetic sequential resonance is the base for the entire spectrum of communication & entertainment devices, the same phenomenon in the form of simultaneous transmigratory resonance called coherent, superposed , superconductive

126

## Secret Of Sankhya: Acme Of Scientific Unification.

activity forms the base for a much wider spectrum of para-psychological, astrological, tidal and related spontaneous phenomenon. In physics this coherent state is encountered in the form of ferromagnetism, superconductivity, asymptotic freedom in quark behaviour etc. Based on Sankhya, it would not be wrong to say that all knowledge, intelligence, experience and existence itself is only a vibratory ensemble with an extended field of reducing vibratory count-rate ending in equilibrium. While there is no doubt what so ever of the existence of the para normal, it is not a magical quality.

Disbelief is solely due to the inability of such specialists to communicate in the language of sequential rationality called mathematical logic and as shown above the existing mathematical base just could not expose this simultaneous spectrum hidden, eclipsed or camouflaged behind the “zero” unit of “observational” time. One cannot divide by zero time! As a simple example, a crowd of people would vouch for the single clap in the 10 simultaneous claps episode, whereas the para-normal person would insist on having heard more than one clap (by instinctively discriminating the loudness or potential factor) but he may not be able to prove it rationally. The Aharanov / Bom experiment to detect the phase shift in the potential is in the same category. One important change in the mathematical approach to solving problems in the coherent field must be accepted by the investigator. Since the equation of interactions in the Substratum is balanced every instant, time or cycle varying changes have no real meaning but every integer count has; for it follows a logarithmic process. Hence the number of real alternative answers are as many as the counts involved and the maximum in the Sankhyan cycle is  $10^{50}$  ; so if he is prepared to do as many iterations then he is assured of having a complete knowledge of all phenomenon in his scale of existence, meaning that there is no uncertainty in

127

## Secret Of Sankhya: Acme Of Scientific Unification.

the Substratum but only the impossibility of dealing with such large simultaneous numbers on a sequential basis. This concept, attributed to Dirac and other physicists, goes under the name of large number hypothesis in physics. The logic is explained in Suthras 46 to 50.

Since Sankhya principles are based on self evident axioms the problem of re-counting of the common cube at the junction gets eliminated automatically by the concept of self-similarity in numerical integer combinations and in fact it commences where Fourier, accredited with developing the periodic wave analysis transforms, left off – at the zero interval. The example of the “simultaneous ten claps within the instant”, exposes the zero time interval between the ten claps and the current mathematical procedures cannot deal with it accurately and precisely. The simultaneous ten claps will superpose instantly to produce a square wave edge approximation in zero time by applying Fourier principles. A vertical edge of a true square wave is a simultaneous representation of two sequential events at two different potential levels at the same instant and both of which are the equivalents of the “point” in space and the “infinitesimal” in time. Since only vibrations are being dealt with, the potential difference, signified by the vertical height in a square wave, must be identifiable as a real physically fixed location for at a “zero or instant” time interval it is impossible to measure a rate of movement. Logic demands that the two different potentials, at the top and bottom of the vertical edge, at the same instant, must have a scale-invariant interactive connection, without violating the principle of causality. In the language of special relativity, it forms the ideal static rigid measuring rod that must follow the same rules of mathematical logic.

Could there be a mathematical procedure that interactively connects, two different potentials of two simultaneous activities at different levels, simultaneously within the

128



## Secret Of Sankhya: Acme Of Scientific Unification.

instant? Such a mathematical process exists in the form of a Moolaprakriti self-similar integer power series that does not contradict the known laws of science. It polarises this vertical potential in infinite ways through “infinitesimal simultaneous rotations” in identical time constant intervals with predetermined coefficients to balance the super symmetric state of the undetectable components of the Substratum to a constant unity value by tunnelling. The quantised rotation or change of phase is done by mere sliding the index of the self similar ratio, up or down by one unit at any point and all the other index automatically change to equalise to unity at the SAME moment. It is scale invariant and functionally the equivalent of metric Euclidean space dealt with in relativity. It means that, if the interaction along the x axis varies as a kinetic change in velocity or frequency then the y axis must also simultaneously vary as a potential change in wave numbers or height to keep the vector sum constant. It introduces the necessity of endowing even a line integral in electromagnetic theory or a geodesic in general relativity, with an identifiable potential value that has a starting gradient of 1 by 2. It was this factor that the Lorentz transform identified but was interpreted as shrinking rods and slowing clocks as space was thought to be empty and moving particles as independent bodies with specific identifiable characteristics.

In special relativity, briefly the definition of simultaneity is, that two events at A and B appear at the same instant when observed from the midpoint M of interval AB. If M is real and occupies even an infinitesimal space it is impossible to establish the real centre because two observers can never occupy the same location at the same instant, (the common axis point mentioned earlier must belong to one or the other half) and any observational process is time-cycle dependant that has an inherent uncertainty so theoretically simultaneity could never be

## Secret Of Sankhya: Acme Of Scientific Unification.

established by such a process of measurement. The mathematical notion of an infinitesimal lulls one's reason into accepting its insignificance but the awareness, that there exist virus and micro-organism with functions as complex as humans, in its scale, must open our mind into accepting the need to change our view of space and avoid the generalisation that the concept of the infinitesimal can be extended to any level. The point, infinitesimal, line integral, null geodesic and other such mathematical and mental artefacts of supportive logic do not really exist in isolation or as absolute values. The reciprocal value of the infinitesimal displacement field is a large number that must stand for a coherent potential in a relative theory.

Logic demands the recognition of the complementary aspect of any parameter: Small time interval leads to high energy rates or a spatial point similarly spells out a large coherent potential. One cannot be without the other and that is what Sankhya emphasises a number of times. The hard truth is that everything that man knows is built up by interpreting vibrations and the number of vibrations that can occupy the same place can be infinite, hence a "common point" in three dimensional space can hide a universe of vibrations. But the sad part is that man can quantify the observable universe only by detecting the sequential vibrations he can measure but is oblivious to the simultaneous activity he cannot detect! If man is serious about really understanding ALL phenomenon he cannot ignore this fact but must have the courage and skill to quantify the invisible, simultaneous vibrations by axiomatic means. As a pointer there are 18 incrementally graded quark levels but theoretical premises based on empiricism in particle physics extends it only to 6 levels; exactly a third but the levels are logarithmic.

The ideological relativistic difference between a rigid rod and ticking clock is wiped out in the Substratum because holistically the rigid measuring rod is in fact it's

130

## Secret Of Sankhya: Acme Of Scientific Unification.

undetectable components mimicking a “rigid row of closely packed clocks” showing the simultaneous (same or synchronous or coherent phase) time-cycles and the clock, on the other hand, is similarly mimicked as an “infinitesimal or point “ section of this rigid rod showing sequential phase changes in its state of activity, in the undetectable components of the Substratum. What differentiates the rod and clock is the phase difference (right angle at maximum difference) at the instant of an observable interaction because what the observer is dealing with is only the state of the components in the Substratum and that must be defined by two aspects, the simultaneous and sequential characteristics. More so in any bound or gravitational system due to the phase angle being distorted, by the superpositioning process, towards the “static or massive or attracting” center.

The relativistic phenomenon governed by the Lorentz transform, also exists in the Substratum in contrast to the view in general relativity that it fails in high “density” regions. Instead of the rod shrinking, the potential, synonymous with the vertical edge of the square wave, turns into a vector with a “phase angle” that changes the coherence pattern of its simultaneous vibratory domain or it twists. The product of potential Linga and kinetic Bhava vibratory counts never loses its unitary status, not in zero time nor even in eternity, not in a single count nor even in  $10^{50}$  count rate. It cannot because what ‘travels’ are only vibrational changes. In a fundamentally democratic field it is logically incorrect to accept that two different basic parameters could exist simultaneously or is needed to fulfil the same function.

Therefore conceptually the potential is nothing other than sequential displacements taking place in zero time (or the instant unitary cycle) and the velocity is the potential acting in sequential displacements in multiples of “zero time” or cycles, as viewed by an observer from his position. In his

131

## Secret Of Sankhya: Acme Of Scientific Unification.

absence both 'potential and velocity' merges by acting simultaneously so the net result is that no change or movement is observable. The observers obstructive presence causes the polarisation by upsetting the coherent state which regains the potential balance internally within the cycle. If not, the oscillatory excursions in opposite directions lose its equality, which then causes the central node to move in proportion to the difference or inequality, displaying the quality of movement, velocity or acceleration. It is just vibrations moving along a closely packed plenum of cubic components in a field with a modulus of deformation amounting to  $10^{50}$  count rate.

The concept of a holographic base for all phenomenon requires a constant oscillatory background state, derived from an axiomatic condition natural to physical laws. Otherwise, a dynamic system dependant on a "start and stop or begin and end" parameter will only become another variant of the "Big-bang" syndrome. The value of the constant oscillatory background must be sufficiently large to unequivocally accommodate the observed spectrum of phenomenon. As a logical corollary a faultless system of control is needed to support the maintenance of such an oscillatory value at an exact level, so that it eliminates implosive or explosive runaway conditions in thermal, nuclear, electromagnetic, gravitational and other observed energy groups. Moreover this state of control, must have exquisite characteristics of feed-forward or advanced mode control, tied in with a feed-back or retarded method, backed up by an adequate reserve power loop to meet every exigency, any-where, every-where and for all times. Such a system exists in the Substratum and one of its "random" manifestation in its simplest form to maintain the oscillatory state within a ten millionth deviation band, is the controversial 2.7 degrees Kelvin background radiation, misinterpreted as a remnant of an initial expanding fireball era. In this context, Einstein is

132

## Secret Of Sankhya: Acme Of Scientific Unification.

supposed to have said that God does not play dice but Sean Sheeter (Author of "The unified model of the universe") pithily adds that he gave it to man to play with!

The control parameters in the Substratum covers six sequences in three loops and is specially dealt with in a number of Suthras (55 to 68) which highlights the constant forward control necessary to maintain a Substratum in a coherent and stable state. It is extremely illuminating to find that the intellectual efforts of 5 important scientists like Newton, Maxwell, Planck, Hoyle-Narlikar and Einstein, who laid the cornerstones in physics and incidentally extended it to cosmology, could have unified all the five areas that Sankhya did centuries back. Newton empirically derived the static gravitational macro field parameters at the outer level by developing calculus to prove the concept of a mechanical-object based reality mathematically and established the gravity constant G as a unit of dimensionality. It is half the reciprocal value derived by using Sankhya principles based on the "Thaama-Raja-Sathwa" Guna concepts. The Newtonian derivation is equivalent to using only the Thaama aspect and ignoring the Sathwa and Raja factors involved in the common zero interval that reduced the true G value by half. Maxwell derived from micro field theory the same gravity parameter, that seems very different, by following a combination of empirical and theoretical premises that were similar to the Sankhyan Sathwa concepts but kept aside the Thaama and Raja factors. As shown in a later mathematical example the impedance value 377 of Maxwell space is in fact related directly and exactly to the Newtonian gravity constant G because Maxwell took into reckoning again the common cube between the vertical and horizontal that made a logarithmic difference, which separated the same coherent field as two different E and B axial activities at the observable or sequential level. Planck mathematically exposed this missing common

133

## Secret Of Sankhya: Acme Of Scientific Unification.

cube at zero interval as a quantum with density at the detectable level but the state of mathematics did not encourage him to look into this cubic quantum activity within the instant cycle.

In Sankhyan terms Planck's effort dealt with the Thaama and Sathwa states but he failed to expose the Raja interactive state involving the gravity parameter  $G$  hidden in the quantum as a simultaneous phenomenon that was unimaginably larger than the spectrum he had investigated, for Sankhya shows it to be the repository of all potential. The near ideal Hoyle-Narlikar theory based on conformal invariance eminently unified both the macro and micro fields at the observable level and the attempt to bridge the internal shortfall in potential, by absorption of radiation, was ideologically correct, for it provided both the necessary compensatory "mass" build up and the consequent phase shift in internal coherence (thereby eliminating the Hubble parameter).

However the "instantaneous" mathematical barrier prevented it from predicting phenomenon that could be verified. In Sankhyan terms it justified the Raja link to both the Sathwa and Thaama states in external Bhava time, but it fell short by failing to mathematically provide the tunnelling instant Abhiman advanced potential connection with the Ahankar phase shift to balance the Bhava external change. Einstein bridged the Maxwell shortfall in potential by the Lorentz mechanism that provided an equated relationship to velocity at the exposed or radiated level but failed to extend it to simultaneous or high density regions, once again due to a conceptual breakdown in mathematically appreciating that the point and the interval were as important as the Universe itself.

While Einstein was probably able to realise conceptually the total equivalence of electromagnetic and gravitation phenomenon, he came close to a total unification by his intuitive but arbitrary inclusion of a cosmological

## Secret Of Sankhya: Acme Of Scientific Unification.

constant, that in fact provided the perfect conversion scale of time and space within the instant, but his concept of mathematics and the structure of space confounded by the Hubble parameter, left a logical void that he could not bridge. The fact that he postulated the principle of equivalence brought him very close to seeing the holographic nature of phenomenon but the power of geometry by Reimann and others held sway. The fact that the principle of relativity led naturally into an enigmatic 'four' dimensional space gave the clue to the holographic nature of reality. One would be forced to describe a hologram in terms of an understandable 3 dimensional space in which the time varying vibrations remained in the same locations leading to the illusion of four dimensions.

In Sankhyan terms he investigated the Raja characteristics just outside the instant, the external metric of spatial "infinitesimal distance and zero time" which were in the sequential Bhava domain, but failed to connect the Abhiman / Ahankar phase lying just alongside, inside the instant cycle. Maharishi Kapila taught man this little trick of peering over this "instant" barrier, by making him mentally change the so called horizontal axis 'velocity or Bhava' representation, onto its head, as a vertical axis 'potential-Linga-vector' as an Abhiman potential in instant time. The description of cubes stacked in the x and y axis depends very much on the observers orientation. Sankhya proved that both were exactly the same in a holographic, oscillatory, field of the Substratum, that is in a coherent, synchronised, eternally dynamic, unmanifest state of total democratic, self-similar freedom called Kaivalya; which is the ultimate yet it is also the original primordial state. It would not be wrong to create an axiom which says "vibrations remain vibrations despite all changes and manipulations" and "vibrations remaining in the same location make it look solid".

## Secret Of Sankhya: Acme Of Scientific Unification.

Aharonov-Bom's experimental verification of the hidden vector potential, the EPR experiment and Bell's theorem, among many others, are hesitant confirmations of the validity of the Sankhyan concept of the Substratum. Every scientific intellectual, Mach onwards, has sought a universal connection and at the same time abjured the conceptual dependence on a preferred or postulated base to describe the Universe. Maharishi Kapila's mathematical definition of the Substratum makes it truly democratic and satisfies the highest principles of theoretical evolution. In physics and chemistry the reason for the "peculiarity" of the particle spectrum and the periodic table is due to the Linga (superposed) - Bhava (phase shifted) polarisation of the coherent potential illustrated above and science has regularised it into an acceptable mathematical regime through a generalised atomic table periodicity formulation like  $(2 \times n^2)$  which overcomes the error of a recount of the common cube, by dilution.

To illustrate, the true periodicity at the basic level of integer combinations is  $(n^2 + n) \times \frac{1}{2} = P$  but when the value of  $n$  is very large  $P = n^2 \times \frac{1}{2}$ . As an example if  $n = 2$  then  $P = (n^2 + n) \times \frac{1}{2} = 3$  whereas by  $P = n^2 \times \frac{1}{2} = 2$ . At the level of the Substratum this aspect cannot be overlooked. Sankhya solves this problem by a combinatorial process using integer number series that not only applies to the atomic periodic table but also to every interactive state of the components in the Substratum, in exactly the same way and the same scale. In the process, it eminently clarifies the reason for the "ladder or nested" mass/energy structure of the entire spectrum of atomic and nuclear particles with only three levels of classification right through the quark spectrum, the Planck mass and finally the blackhole.. The Substratum has it all. Everything that man wants to invent, discover or find by experimental stone-throwing, is already there. What is needed is a holistic approach coupled with intellectual

136



## Secret Of Sankhya: Acme Of Scientific Unification.

clarity and a responsible attitude to objectively use this treasure house just for his wellbeing but strongly resist the temptation to exploit it, for it is also the source of all intelligence that ruthlessly controls imbalance by initiating a reactive process instantly but to be completed in future time. Now, the most important conclusion from the foregoing explanation is that it can only happen in a Substratum compatible with the Sankhyan definition based on a holographic model of phenomenal interaction. Further, the Sankhyan success in explaining interactions at the basic level confirms another axiom that is often overlooked in mathematics and that is, logically an elementary unit less than one cannot exist in reality and conceptually one is infinity upon infinity.

## Secret Of Sankhya: Acme Of Scientific Unification.

### Summary Of Suthras.

The original Sanskrit Suthras were created for oral transmission as evidenced by the metrical format and the austere presentation of a subject of such complex structure. The manuscripts, though accurate in its effort to convey the original meaning, contains several ambiguities that naturally creep in over long periods. Differences in several manuscripts from varying periods have created an uncertainty and vagueness which has lead to depending more on the original phonetics for decoding th correct meaning. Hence the phonetic presentation in the Roman script is analysed and decoded in the “Detailed Analysis Of Suthras” section.

Though the Sankhyakarika ostensibly belongs to the shelves of Vedic philosophy and religion, its axiomatic mathematical contents on the contrary, compels its placement on the racks of Cosmic & Particle physics and Quantum Mechanics. Therefore an overview of the real meaning of Sankhya Suthras is given here to impress on the scientifically oriented intellectual, the rational flow of scientific thinking at its logical best. The actual translations will show the rigorous and irrefutable logic that connects the original Suthras in Sanskrit to the theorems presented in English. The headings, though not in the original, have been created to highlight its essential meaning.

#### **Fundamental space**

##### 1. The dynamic substratum:

Investigating the triad of interactive stresses confirms that such interactive modes of stresses exist but it would not have been detectable, had it not been for the existence of the coherent - perpetual - dynamic - unmanifest state of its existence (of the substratum).

##### 2. Qualities of substratum

Standard methods of evaluation through detection are affected by distortion, attenuation and inferior resolution

## Secret Of Sankhya: Acme Of Scientific Unification.

to details; but an alternate method that is totally satisfactory, is based on the principle of discriminating the basic and dynamic substratum into its appropriate components of the unmanifest, manifest, the self-potential and kinetic or dynamic potential.

### 3. Axiomatic 3 dimensional wave fundamentals of substratum.

: The fundamental resonant oscillatory state is synchronised, coherent, resonant and stable; the first interactive oscillatory state is of maximum intensity of acceleration; then there are seven levels of coherent, harmonic and oscillatory interactive stages followed by an expanding radiation above a sixteenth order of the fundamental value; the nuclear core is neither oscillatory nor harmonically interactive

### **Intellectual Verification**

#### 4. Verification of reality through axiomatic proof.

Siddhi or conclusive holistic proof is arrived at by a process of logical and theoretical analysis of information from observations, inferences and axiomatic principles. When such holistic conclusions are further condensed by using the threefold analytical process with appropriate rationale and theory, it is established as a conclusive axiomatic theorem.

#### 5. Process of verification of detectable phenomenon.

With reference to persistent continuous sensory perception of phenomenon, there are three aspects of information with characteristics like (positive) detectable, (negative) undetectable, (neutral) original characteristics that can be measured, analysed and interpreted to establish an axiomatic theorem or principle.

#### 6. Process of holistic derivation of proof is Siddhi

And in the case of phenomenon that is imperceptible, mobile, expansive and hence undetectable, inferential method using holistic, deductive, logical, verification

technique to mentally experience phenomenon, is known as Siddhi (perfect resonance).

**Axiomatic reasons for nondetection**

7. The reasons why manifestation may not be detected.

Extremely far or near distances, mental and sensory inefficiencies, subtle or attenuated conditions, occultation or eclipsing of the object, poor background contrast, camouflaging effect (are the causes of non detection or non measurement of phenomenon).

8. Reason why the fundamental substratum is not detectable.

The non-detectability (of the substratum) is due to the extremely attenuated reactions put out and not because it (substratum) does not exist. Only reactions are detectable. For when the reaction of the primary or first displacement takes place then a sequence of oscillations are detected that are either in its original form or harmonics.

9. Logical reasons why substratum must exist if manifestation exists.

It is axiomatically illogical to accept that continuous or all possible modes of action (manifestation) are possible without a physical cause; the ability to act in all possible ways must be due to the existence of a cause, therefore it becomes an axiomatic rule.

10. Detection of manifestation is due to changes, the lack of which makes phenomenon undetectable.

The caused detectable effect of manifested phenomenon are relatively temporary; confined to limited region; proceed from action to action; resulting in a sequence of actions; and also becomes the cause of initiating further action; with identified characteristics; has the quality of being substantial or with mass; as it is a resultant, so it is a secondary trait; and the unmanifest cannot be detected because of the inability to discern such effects.

**Self-similar law of interaction**

11. Ability to discriminate 3 aspects of Gunas or interactive stresses is the cause of detectability.

The inability to discriminate between the triad of stressed states that form the dynamic connection is the cause of not detecting phenomenon in a synchronised, static or unmanifest state. The triplicity of dynamic interactions that connect it, is a principle that applies to the first or primary intense state and the succeeding reactive states of manifestation and likewise to the nucleus which however is in the opposite state (non detectable state)

12. Characteristics of Gunas (triad of interactive stresses).

Just as the human being undergoes, when under stress, a three stage transfer from a state of buoyant feelings through a calm state to a state of utter despair; the three interactions of the Guna are from a state of free and mobile expansion through a balanced and resonant interface to a state of compact static contraction. As a result the three states are capable of mutually interacting to override or strengthen or weaken, one or both at the expense of the remaining aspects; be creative or destructive as a whole; associate or join or pair or combine to form groups; and also exist by itself as a self supporting resonant or dynamic entity.

13. Definition of Gunas.

Sathwa is the interaction which operates outward at the maximum rate with the required intensity and energy to transmit the interaction beyond the level of the first octet of interactions past the nuclear boundary that is in a fluidic or flexible state;

Raja is the interaction in the transition region of seven oscillatory plus the first forming the octet of interactions; that shuttles inward or outward to transfer the interactions from nuclear boundary to the second radial boundary and vice-versa;

## Secret Of Sankhya: Acme Of Scientific Unification.

Thaama is the decelerating interaction acting inward forming the static nuclear boundary;

Vrithi is the resultant interaction that is radiated in the form of a self-sustained vortex of radiant energy created by the permutations and combinations of the previous three levels of interactions to transfer interaction or radiate energy.

### 14. Holistic logic can predict hidden states.

Through a process of holistic analytical derivation of proof it is proved that non detection or detection is due to the observers inability or ability respectively to detect any or all of the three modes of exchange or transfer of interactions. And the very process of Siddhi or 'holistic analytical derivation of proof' is itself due to the unmanifest state of the substratum reacting through the action of the Gunas or three modes of transfer of interactions by it's own inner motivation or potential or cause or interaction to manifest as awareness or consciousness .

### **Phases of oscillatory states**

### 15. Cyclic oscillatory interaction creates natural waveform.

Cyclic interaction at the interface is due to a sequentially changing value that is due to acceleration or deceleration of an interaction . This cyclic action is the cause and effect, by turns, to attenuate and concentrate (expand and contract or decrease and increase density) to produce an oscillatory waveform that is a standard in nature.

### 16. First change of phase occurs with increasing interaction.

In a manifestation of decelerating potential ,the triad of interactions is initiated into action resulting in a rising or increasing effort, interaction or pressure; and a transformation occurs ; a distinctive change of state, like that of vapour condensing to liquid, takes place when the inward going interaction is brought to a very restful(=synchronised therefore static state .

## Secret Of Sankhya: Acme Of Scientific Unification.

### 17. Second change of phase creates nucleus .

The nucleus is the location, centre or core that holds the power, potential, interaction or energy produced as a result of the cyclic collision or aggregation due to close contact, back to back, of the oscillating volumes or waveforms, initiated or triggered into action by the operating principle of the triad of Guna (interactive interactions), in a relatively isolated, free and synchronised state.

[Summarising: the Purusha or nucleus is a superpositioning of three dimensional oscillatory waveforms due to the mode of action of the Gunas in a static state of dormant potential in the undetectable, absolute substratum that is synchronised and coherent, perpetually dynamic but unmanifest and the period being determined solely by the time constant referred to in suthra 3 that forms the self potential referred in suthra 2. ]

### **Nuclear state as superposed coherent activity**

### 18. Logical proof that the nucleus is a conglomerate.

Since the causative action leading to aggregation and dissolution or creation and destruction are not simultaneous or instantaneous at the nuclear interface the holistic conclusion is that there must be many nuclei or individual core components (Purusha) and also because the reversal of interactions of the triad of interactions (Gunas) produce multiple types of phenomenon whereas it should have been singular, (had the nucleus been a singular or elementary object).

### 19. The complex nuclear state forms background for manifestation.

From previous Suthras the conversely inferential holistic conclusion is that the nuclear state forms the background with particulate or inertial mass, in which it is relatively seen as being neutral, unhindered and static.

### 20. Static and dynamic state is sustained by interaction.

Because of the proximity of the static and dynamic states the static state seems dynamic and through the action of

## Secret Of Sankhya: Acme Of Scientific Unification.

the Gunas the dynamic seems to behave in a static mode that maintains a balance.

### 21. Nuclear state is reference background.

Fundamental measurement of phenomenon references nucleus. Therefore the static nuclear state provides the basic background to detect or measure the first, (primary or fundamental) active (manifested) state as a comparative or relative difference. Manifestation of phenomenon proceeds on the principle of fulfilling the need to maintain a balance like when a blind man and lame man team up to behave normally and effectively.

### **Logic of self-sustaining activity**

### 22. Mathematical derivation of the dynamic self-similar state.

By the action of the primary interaction a self sustaining oscillatory state is established from which a series of measurable or detectable energy is radiated at a value that is at a sixteenth power of the primary value and in a progressive series incremented to the sixteenth level that binds or condenses phenomenon through five levels into five sets of manifested phenomenon.

### 23. Ascertainment by axiomatic mathematical logic,

Intellectual logical confirmation process involves the application of axiomatic law in an expansive mode, backed with knowledge, flexibility to change scales and ratios in the order of powers whereas the opposite contractive, inverted and fractionising concepts lead to misconceptions and errors of judgement.

### 24. Mathematical description of field force as a spectrum.

Static potential and kinetic self-similar force (or energy) initiate action in a progressive incremental value in sequential sets of two to form a spectrum containing a sequential group of eleven, in groups of fives, of field (subtle) forces.

### 25. Expansive interaction rises to 11<sup>th</sup>. Power



## Secret Of Sankhya: Acme Of Scientific Unification.

The expansive Satwik state has a set of eleven levels of change. The compressive Thaamasic change initiated through self-action elemental particles with mass and self-sustaining vortex of charge the interactive Rajasic state is both expansive and compressive.

### **Cerebral system as an universal function**

#### 26. Efferent and afferent sensory systems.

Efferent or input sensory responses are light, sound, smell, chemical (taste) and contact (touch) and the afferent output or action responses are defined as oscillatory, exchanging, transporting, radiating and creating.

#### 27. Interactions in the sensory systems.

Mind or the cerebral system is capable of processing both the efferent or incoming input sensory information and afferent or outgoing action oriented outputs and it can produce a specific output despite the diversity created by the permutations and combinations of the internal aspects of the three Gunas with the numerous external incoming signals.

#### 28. The five levels of cyclic vortex (photonic) activities.

The five types of sensory input signals are activated by discrete quantum of forces and it results in five categories of output as oscillatory, interactive, transmigrating, radiating and creative activities.

### **Perpetual oscillation and radiation**

#### 29. Definition of self similar internal activity and radiation

The cyclic vortex functions on self similar principles upto the third power, is non-synchronous, and yet interacts internally together in an extraordinary way. But in the synchronous accelerated state at the fifth power it becomes a fundamental unit of energy radiation.

#### 30. Definition of a cyclic vortex and a spherical harmonic oscillator.

When the oscillatory cycle count in all directions act simultaneously or synchronously and is raised to the 4<sup>th</sup>.

## Secret Of Sankhya: Acme Of Scientific Unification.

Power, a cyclic self-supporting Vrithi (photon) is formed. When it acts non-synchronously or sequentially it becomes detectable and measurable with a degree of certainty. In the initial state prior to the above when the oscillatory count reaches the power of three and is synchronised and acts simultaneously in all directions, it is in a self supporting harmonic oscillatory state but is not detectable or observable.

31. The cyclic vortex is kept in continuous oscillation only by its internal potential.

The cyclic vortex or spherical oscillator is kept in continuous interactive exchange upto the very end (limit) only by the nuclear or core potential developed by the mutual exchange of internally motivated and triggered self similar and self organised impulse or force and there is no other external potential cause.

### **Potential as coherent states**

32. The static and kinetic potential limits.

The potential rises to the 13<sup>th</sup>. power to accelerate superpose and radiate. Consequently the kinetic potential rises to the 10<sup>th</sup>. Power to accelerate, superpose and radiate.

33. The internal and external potential limits.

The internal limit of potential is at the third power and the externalising detectable factor defined as existing in present time is upto the 10<sup>th</sup>. Power. The third power factor contributes to internal bonding or it is a limiting state .

34. The potential to act is at the 5<sup>th</sup>.power level.

The will or internal potential to act increases rate to 5<sup>th</sup>. power of both the specific and non specific or the observable and the hidden sensory signals. Sound signals relate to speech or oscillatory functions whereas the rest relate to all the five observable interactions.

**Third order constraint cause phenomena**

35. The formation of a basic field is determined by the 3<sup>rd</sup>.  
Order damping action.

At the point when all measurable interactions plunge to its limit and form a coherent bond it is a measure of the effort involved and therefore the third power of this bond forms the base or limiting medium , the remaining powers of interaction use this as medium.

36. Decay of radiated phenomenon.

Spectrum of light transmission process is a complex and mutually interactive Guna exchange sequence and it is totally controlled by the Purusha potential and it is the only coherent motivating factor clearly till its end.

37. Extraction of potential energy from the Purusha domain.

A comprehensive and extraordinary use can be made in the following way. The potential of the Purusha can be attained from the minute coherent state hidden inside the Purusha by repeated precisely triggered inputs to initiate the primary interactions.

38. Classification of activity of Vrithi and elements

The self-generated vortex or Vrithi has a non specific or wide range of activity level while the elements are at five levels upto the fifth power of activity . The spectrum logically covers the classes of activity states defined as synchronised, non synchronised, interactive, superposed and coherent

39. Genetic code

The field sustained by the fundamental source of energy bonds into three organic species. The mobile field is constant and controlled and the organic states of three species are cyclic or periodic.

**Superposed states create ground potential**

40. Linga state as coherent and superposed oscillations.

Static mass states are created by maximally absorbing and superpositioning the entire spectrum of vibratory or  
147

## Secret Of Sankhya: Acme Of Scientific Unification.

oscillatory states, from the largest and strongest to the (limit) finest, minimal kinetic charged states.

### 41. The need for the substratum as supporting framework for manifestation.

Just as it is not possible to present a picture without a supporting base nor cast a shadow without an appropriate pillar, so also it is impossible to have the synchronised and superpositioned static state without the required supportive base.

### 42. The synchronised state provides attracting potential to build up mass.

The synchronised and coherent state of the nuclear core forms the target potential to attract the oscillatory interactions to synchronise and superposition itself circumferentially, simultaneously, similar to the movements in a dance, which increases and strengthens resonant state of the interactions .

### **The balance in interactive states**

### 43. Conditions under which the laws of interaction are certain.

The source or starting point of the axiomatic laws of resonant action are from the state when the charged interactive state is in a state of perfect resonance and the starting point or start of time-cycle-period count of measurement commences when the action is in a state of relative rest or static state for detection is only possible when the detected component is at a restful state.

### 44. The mode of natural action based on rules.

Satwic expansive actions are supported by axiomatic laws and expands towards a free state but actions opposing it results in reduced states that leads to Thaamasic or compressive states that are restrictive. Inner self potential is the only cause of synchronisation and establishment of coherent state but obstruction or restrictions results in a confined and bonded state.

45. State of unbalance is the motivating cause of manifestation.

When the Rajasic interactive states are equal and balanced, accumulation or increase of mass by absorption or superpositioning of active displacements occur. When unbalanced or unequal the increase or decrease in force causes acceleration or deceleration creating the manifest spectrum of universal phenomenon.

**Spectrum of interactions defined**

46. Interactions in the synchronised state causes 50 orders of change.

The ascertained order of the spectrum of interactive states due to the conditions of unbalance, non synchronisation, balance and coherent synchronisation caused by the interplay of three Guna modes of interaction rise upto 50 (power index).

47. Balanced , synchronised and its reversed variation sequence of interactions.

A sequence of 5 orders (power index) of change is created by the three varying states of interaction like non-synchronous, interactive change and synchronous. Weak and unsynchronised states have 28 orders while the balanced phase has 9 orders and the perfectly synchronised state has 8 orders of sequentially variable levels.

48. Order of compression increase when one, two and three axis synchronise.

Interactive changes in the compressive Thaamasic state proceed on the basis of 8 orders of change along one axis and increases by the same order when it synchronises with another axis at a deeper level. At the next intermediate level it increases by 10 orders and at the final core level it increases by 18 and by another 18 at deepest core level synchronisation. That is  $8 + 5+4$  , followed by (5) in each axis and finally  $(8+10) 18$  . It is a combinatorial process of incremental rates that can synchronise and remain in balance only as even numbered levels.

49. The 11 & 17 orders of the weak and balanced groups.

Eleven orders of expansive interactions cover the observable range out of the previous 28 orders mentioned before. The balance of 17 orders consists of the balanced and coherent states and the radiant states. With the 5 orders of radiant state it forms 22 orders. The 17 orders form the common potential to both phases.

50. Nuclear balancing parameters

The interaction inside the nuclear state can be defined as at the fourth power, initiating cause of action and responsive self reaction, the time period of the reaction and the destined potential available for the reaction. Externally detectable fundamental activity is categorised as being at the fifth power and when these two act together synchronously it is the ninth power.

**Interactions cause stress.**

51. Colliding interaction cause of vibrations.

Knowledge gained through research on vibratory or oscillatory stress caused by colliding interactions follow three step action (of compression – shuttling- expansion – Guna mode) leading to intensive superpositioned, divergent, or synchronised states, raised to the eighth power in a coherent mode. The original state prior to the interaction has been established to be in a controlled, compressed, cubic, volumetric state, raised to the third power.

52. The polarisation of phenomenon into coherent potential (mass) and kinetic potential (charge) modes.

Neither can a characteristic potential source exist without a kinetic phase nor can a potential phase without a kinetic mode. A vorticular particle is initiated by a potential source. The potential is classified as mass and the kinetic phase as charge from which dual combination all phenomenon is initiated and maintained by a dual mode of polarisation.

53. Guna classification.

## Secret Of Sankhya: Acme Of Scientific Unification.

Natural or inorganic or matter oriented phenomenon is the result of 8 orders of variations and the organic or sub human order is fivefold . The human order is from a single variant, these three classes succinctly control the complete spectrum of phenomenon.

### 54. The distribution of Guna interactive states.

Ascending order of outward manifestation is predominantly Satwic and the descending inward mode of creation is predominantly Thaamasic and the intermediate range is predominantly Rajasic and it is consistently so right from the starting dynamic creative field to the final coherent static order of manifestation.

### 55. Stress in three modes follows self similar laws in the dynamic substratum.

Therefore the process of decay and absorption introduces interactive stresses that maintain the dynamic state of the Purusha and on its absorption of the vorticular interactive activity by the nuclear core the process of superpositioning continues until the interactions are minimised and a coherent self similar state is established.

### 56. Manifestation is the result of interactions to maintain the balance between nucleus and boundary.

In this way interactive oscillatory activity is initiated and perpetuated from the intense fundamental activity at the source to the final coherent superposed massive state at the isolated nuclear boundary where the self potential balances with the reactive potential at the starting point .

### **Coherence causes potential states**

### 57. Attainment of a coherent superposed state initiates oscillatory state.

The growth of a calf is due to the flow of milk that seems to have commenced without a cause or specific instruction ; in a similar way the formation of the nucleus takes place by the stress transmigration of a static potential through the gradual attenuation of the primary kinetic force into a synchronised state of freedom by its

## Secret Of Sankhya: Acme Of Scientific Unification.

own internal motivation or initiating activity to balance forces.

### 58. The unmanifest state maintains the potential to act.

People are motivated into maintaining a state of activity to reduce their zeal for action; similarly the unmanifest state maintains the Purusha in an isolated state free of stresses by absorbing the stresses of the continuous static through kinetic balancing interactions.

### 59. Forming of nucleus due to reduction of potential difference

Just as the external exhibition of a dancer's performance reduces his urge to continue his performance because it satisfies his desires; similarly the outward spreading of internally motivated self energy diminishes its potential to radiate and thereby reaches an interactive state of balance in an oscillatory state.

### 60. Cause of interactive oscillations

Various factors, controllable, corrective, supportive, non-supportive nuclear state along with the interactive Guna qualities and its opposite coherent superposed states of dynamic and non dynamic, potential and lack of potential maintains the oscillatory activity.

### **Synchronisation causes holographic states**

### 61. The oscillatory displacement at the point of balance is very attenuated.

At the nuclear boundary the oscillatory displacements reduce to such a minute angular oscillatory movement that its very existence seems doubtful. The consequent reduction in the interactive self potential does not ever allow it to radiate detectable information on the state of interaction of the nuclear region.

### 62. Interactions are cause of manifestation as a holographic phenomenon.

Therefore nothing is bound, released or translocated. Only the oscillatory wave forms of interactions is bound or superposed by synchronisation, released by



## Secret Of Sankhya: Acme Of Scientific Unification.

desynchronisation and transferred by transmigration due to unequal displacements and this dynamic state continues endlessly.

### **Self-similar interactions**

#### 63. Interaction.

The oscillatory waveforms superposition itself by its own potential to form the nuclear density by compressing its waveforms to the seventh power when it becomes equal to the static nuclear potential and when it expands it releases one waveform at a time.

#### 64. The lack of specific self-potential leads to a ground state.

Hence fundamental research indicates that non availability of self-potential is the cause of the existence of a potential sink (ground state) and not due to any precise measure of interactive control that a pure changeless ground state exists (in the nuclear core of the components of the substratum.)

### **Equalisation of potentials**

#### 65. The state of balance when the nuclear boundary is in balance.

When the oscillatory interactions are minimised because of the reduction in activity between the boundary and nuclear core, the interactive current becomes neutral and the activities at the seven radial levels becomes insignificant, the Purusha attains a firm background state.

#### 66. State of balance by eliminating the potential to act.

Observing the neutral state of one gives the proof that the observable movement of the other has ceased and even though both are together no interactive manifestation exists.

### **Conversion of charge to mass**

#### 67. Conversion of kinetic force into static potential as inertia or mass.

The basic principle of acquiring a solid state or mass is by synchronising the components into a relatively static level

Secret Of Sankhya: Acme Of Scientific Unification.

by allowing the spin angular momentum to be converted to a potential state. The exchange or accumulation is through a self similar proportion or ratio.

68. The final synchronised, coherent , dynamic state of isolated nucleus.

The process of acquiring mass is given effect by superpositioning the interactive vortex like waveforms by changing it into a gradually diminishing cyclic interaction that reaches a synchronised and coherent state of balance within the first or primary activity boundary. Attaining the synchronised and coherent state eliminates delay, inertia or friction and allows this state to continue unhindered in complete freedom.

### **Heirarchy of knowledge transmission**

69. The knowledge of the nuclear potential is codified in this work

The knowledge of the nuclear potential is encoded in this work by the great Maharishi where-in the method of intellectually ascertaining the process of manifestation of phenomenon from its origin, through its growth and till its dissolution are explained.

70. The hierarchy of information transmission

This pure and exotic doctrine the sage gave to Asuri who in turn handed down to Panchasikha by whom it was extensively propagated as the perfect set of principles explaining the mode of action in reality

## Secret Of Sankhya: Acme Of Scientific Unification.

### Detailed Analysis Of Suthras.

[Note: The English translations from Sanskrit have been decoded contextually and may differ from the traditional translation. The Suthra sub-headings have been added to indicate it's contents and is not a part of the original. The magnificence of Maharishi Kapila's intellectual skill is confirmed by the fact that space which is the Substratum for all phenomenon, is never identified directly or named as such, in order not to reduce it to the same state as ordinary phenomenon, because the Substratum as defined axiomatically by him is the fundamental and absolute state of 'being or existence' that is equal to a divine state which follows one axiomatic law.

The Sankhyakarika unifies all aspects of human intellectual investigations into a single process defined through axioms, from start to finish, thereby unifying science and religion, the two apparently confrontational modes, further complicated by an arbitrary division of material and spiritual qualities, in investigating reality. Veda means 'weave that which exists' or unify existing nature through logical reasoning or laws.

All the Sankhya Suthras in Sanskrit have been transliterated into English and the closest holistic meaning of the complete Suthra is given below each Sanskrit verse. As already emphasised in the earlier section, the phonetics of this early creation seem to be more important than the later scripted creations. The corrected phonetic characteristics are given in Appendix 6: "The Sanskrit Language" The specially prepared Lexicon in the appendix section contains a glossary of Sanskrit-English equivalents of all the key words in the Sankhya Suthras.

The Sanskrit terms in the Suthras contain advanced technical information that are not covered by standard dictionaries. Sanskrit dictionaries invariably highlight the passive, static or generalised meaning, which relegates the

## Secret Of Sankhya: Acme Of Scientific Unification.

dynamic characteristics to the inferential level. Hence these have been decoded through the Siddhi process and collated by a computer program based on contextual reference and statistical comparisons. As indicated in the introduction, the first Suthra itself has been mistranslated due to conceptual errors. (See Comparison in the appendix section for the analysis of the first Suthra.) The Preface and Introduction contains the general principles on which the holistic meaning of the Suthras were derived. Re-iterating those thoughts again, the Sankhyakarika intellectually derives the Substratum of all manifestation through rigorous, axiomatic logic. There are no **experimental inputs of any kind in Sankhya**. Yet all the scientific parameters derived only from axiomatic statements have been found not only to be correct but also accurate beyond expectation. Numerical values of formulas are given to see its extraordinary accuracy and equivalence at a glance.

The final mathematical equivalent is given in both standard and integer mathematical notation. As explained in the Introduction, the Suthras must be integrated and understood by the Siddhi process of Suthra 6. Hence explanations cannot be confined only to the Suthra being dealt with but the derivations from later theorems have to be brought in and may seem pre-emptive. As the Suthras are presented in a terse and concise way, what may apparently seem to be arbitrary back and forth references, cannot be avoided if a complete and cogent explanation is to be given at the appropriate stages.

Another significant point must be noted that the very first Suthra in almost all important Sanskrit works contains the core theorem and if one is able to understand it thoroughly, analysing the rest of the supportive theorems become a secondary procedure or a corollary. In Sankhya it is particularly true and the explanations below contain the essential core mathematical principles in brief from all

## Secret Of Sankhya: Acme Of Scientific Unification.

the Suthras. Suthra 1 is a pivotal theorem and provides the basis to understand subsequent Suthras. The descriptive heading along each Suthra stands for a summarised meaning derived from its contents and is not a part of the original text. It displays at a glance the contextual meaning and also highlights the logical connection to the preceding and following Suthras. The Sankhyakarika in its original form was created for an oral transmission process following the rules of metric verses. Hence it is essential to follow the Siddhi process, mentioned in Sankhya Suthra 4,5 and 6 to relate and connect the verses.and understand its real meaning.



**Suthra 1.**

The Dynamic Substratum

***dhu:khathrayaabhighaathaajijnaasaa***

Stress triple interaction investigations

***thadhabhighaathakey heythau .***

Such interactive modes exist .

***dhrishtey sa'apaarthhaa***

detection of such would have been meaningless

***chennaikaanthaathyanthatho'abhaavaath .***

were it not for the synchronised perpetual dynamic unmanifest state.

**Meaning:** Investigating the triad of interactive stresses confirms that such interactive modes of stresses exist but it would not have been detectable, had it not been for the existence of the coherent - perpetual - dynamic - unmanifest state of its existence (of the substratum).

**Explanation:** Only a change can be detected and an interaction between components or objects causes a change that can be observed. An interaction that is not observable or detectable causes a stress. A resonant interaction continues endlessly if it is balanced. If an interaction is obstructed then the reactions from it accumulate at that point. A stress is caused if there is a lack of freedom to balance out or equalise immediately. stresses accumalates as a pressure or force if there is no way to release it.

**Du:khatraya:** Du:kha is stress (See Comparison Of Sankhyakarika Translations in the Appendix), in this context. Interactions cause collisions or colliding states which normally implies the existence of a velocity component prior to an impact. But in a sea of components forming a continuum such a free movement would not be possible but the pressure of contacting or interacting with

## Secret Of Sankhya: Acme Of Scientific Unification.

adjacent units would create stresses and these could be inward or compressive or outward and expansive or just an in between resonant shuttling state. These three variations in an interaction take place cyclically in such an ocean of identical components, whatever these might be. These interactive stresses are stored over a period of time, released periodically or immediately. These three aspects form the 3 modes of accounting the state of stress over a time period. The definition of the three Gunas refer to these states of stresses as Du:khatraya.

Three modes of interactive stresses are described in Suthras 11 to 14 as the Three Gunas. One of the meanings of Guna is 'a bowstring' signifying a tensor or vector aspect of a force, like the taught tension in a resonant bowstring. Any interaction has three characteristics like hard or inelastic collision, springy or elastic reaction to an impact and a spongy or resonant shuttling phase. The three modes of interaction are a natural or Swabhava type of reaction to distributing of interactive cyclic time in a self similar way.

Thaama Guna is compressive, dense and inelastic, Raja Guna is resonant, shuttling and bonding and Sathwa Guna is expansive, radiant and elastic, interactive states. The interactions being in a confined or restricted space like a sea of identical components or a field of elemental matter, the interactive changes can only take place by exchanging the differing parameters in a simultaneous process. Such a process is defined as a self-similar or Swabhava type of interaction and defined in the respective Suthras. In terms of cyclic time it must be considered an instantaneous process or action within the smallest cyclic period. Hence expansive, compressive or resonant activities caused by an interaction will be proportional to the logarithmic or multiplicative product of the interactive parameters. Taking C as cyclic rate of oscillation or vibration and x as rate of change per cycle then the three Guna self similar

160



## Secret Of Sankhya: Acme Of Scientific Unification.

interactive states are shown as vibratory counts per cycle by the formula .

Equation S.1

$$\text{Thaama} = C^{1+x} . \text{Raja} = C^{x+x} . \text{Sathwa} = C^{1-x} .$$

The above values are logically derived numerically in their respective Suthras. Then the meaning of Suthra 1 is that these three forms of interactive stress could only exist if the substratum or field of components in space had the following four qualities namely Aikaantha, Aathyanta, Atho and Abhavath, as being synchronised , perpetual, dynamic but an unmanifest state of existence. These states are analysed and its axiomatic values derived below. The diagram below will clarify the concept The

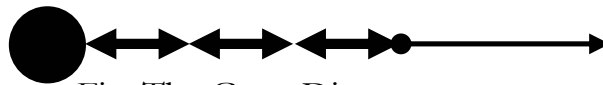

Fig: The Guna Diagram.

dot represents the stored stresses in the Thaama compressive, dense, coherent and stable state of Aikaantha. The double arrow head shows the periodically released Raja interactive, resonant , stationary but transmigratory state of Aathyantha. The long single ended arrow shows the ‘instantly’ released Sathwa expansive, radiant and mobile state of Atho The single arrow indicates that counts along two axis are synchronised. When counts along 3 axis synchronise perfectly in Thaama state then both the double and single arrows turn inwards or ‘dissappear’. Then space becomes unmanifest and undetectable state of Abhaavath and the Universe remains in the Aikaantha state. Therefore space the fundamental reality can be in only one state of Aikantha the coherent state of three dimensional or cubic resonances. Movement needs the fourth power.

**Aikaantha:** It is a sunchronised or coherent singular state where all components act **simultaneously** as a single

Secret Of Sankhya: Acme Of Scientific Unification.

entity in the Thaama state shown as the dot. This can comprise activity in both forms where relative movement between interacting components may or may not exist. That is, relative activity may all proceed together or may be in a sequential form within the cycle. As an example, ten people can clap periodically either simultaneously or sequentially. Though the ten simultaneous claps will be counted as one, it still contains the ten claps. Only the degree of non-synchronisation will allow one to differentiate between the ten different claps. Hence all the interactions can remain together in the same relative relationship of a frozen form or move relative to each other in a cyclic period of movement and yet remain a singular entity. Hence Aikaantha has two mathematically limiting values depending on its state of internal relative movement

Assuming there are n components then the maximum number of possible interactive states must be  $N / 1$ . Comparing the relationship with smallest possible value of an isolated component of one unit, the number of possible interactive states become  $N-1$  and the incremental ratio of a change, simultaneously or instantly, becomes  $(1+(1/(N-1)))^{N-1}$  (as simultaneous interactions are logarithmic): As  $N$  approaches infinity  $F2$  equals the base of the natural logarithm  $e$  in modern terms. If all possible interactions are carried out  $n-1$  times simultaneously then it will approach the value of  $e$  or  $FM2$ . Here the logarithmic sum of the incremental value and its ratio reach an asymptotic or limiting value of a transcendental number..

Equation. S.1A.

$$e = \left[ \left( \frac{N}{N-1} \right)^{N-1} = \left( 1 + \frac{1}{N-1} \right)^{N-1} = 2.7182818285 \right]$$

## Secret Of Sankhya: Acme Of Scientific Unification.

Hence the larger the number of interactive components or larger the relative volume acting as a single unit, it will always tend to equal 2.718 or e at the maximum rate of simultaneous or 'within a cycle' or instant period of interactive changes or counts. Any count of an interaction can be obtained only after the completion of the cycle and therefore the unit count per unit cycle is a relative instant. Aikaantha is an axiomatic state that shows the substratum of space will always remain in this singular or frozen state of dynamic interaction when unhindered.

The next possible variation is a relative cyclic-period difference between the interactive components which can result in a 'rotary' or cyclic periodic movement of the interactive stress forms or oscillatory waveforms. Mainly, Suthras 24, 30, 52 and 55 lead to the derivation of the counts in a cyclic period. Here the interactive forms, despite a relative movement, must remain in the same location to fulfil the condition of Aikaantha or singular or unitary state. The reason is that in any confined plenum or a sea of components or a vast field of matter, where there is no possibility of an external intervention or far from the boundary of influence, interactive exchanges can take place only by a process of simultaneous exchange of required parameters from within itself. This law of Swabhava or self-similarity leads to a unique ratio that defines the value of a cycle as 10, if the Aikaantha state is to be ensured. Axiomatically the rate of variation in cyclic time between any two identical interacting components has to be 1 to 2 as shown in FM3: Problems on vectors etc were solved by variant methods called triangulation long before the Greeks.

Equation. S.1 B.

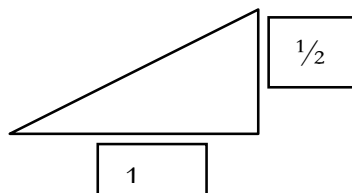

Secret Of Sankhya: Acme Of Scientific Unification.

Solving the cyclic period-difference or ratio by triangulation works out to x as the golden mean:

Equation. S.1 C.

$$\frac{\sqrt{1 + 2^2} - 1}{2} = 0.618034 \blacksquare$$

If x is halved and triangulated, and the difference is again halved and triangulated iteratively and the result multiplied by the

Equation S.1 D.

$$A_0 := \frac{x}{2} \quad A_{i+1} := \frac{\sqrt{\left[1 - \sqrt{1 - (A_i)^2}\right]^2 + (A_i)^2}}{2}$$

$A_{i+1} \cdot 2^i \cdot 2$
0.314139
0.314154
0.314158
0.314159

powers of two raised by the same number of iterations, as follows, then formula is shown as F4. The relationship to the current value of  $\pi$  has been brought in as proof to 164

Secret Of Sankhya: Acme Of Scientific Unification.

show that the cycle is indeed of ten counts, which value is derived further below through other axioms.

It proves once again even an interaction with a relative cyclic period difference will remain in the same singular or stationary position of the Aikaantha state because the sum of all the interactions within the cycle only add up to  $\pi / 10$ , **provided** the initial displacement is **x or x/2**. Even though any interaction is always directed in the line of action, the relative direction between two axis change with a variatio in rate of interaction between two axis. It has an important significance. Regardless of the rate of interactive counts per cycle the interactive stress forms (waveforms) will follow a circular path and complete the circular cycle only after 10 sequential interactions but yet remain in the Aikaantha state as shown mathematically.

Axiomatically there can be only three modes of interaction as derived in the Guna Suthras. Then these three modes can act simultaneously or sequentially. The permutation combinations shown below indicate only 10 possible states as shown below:

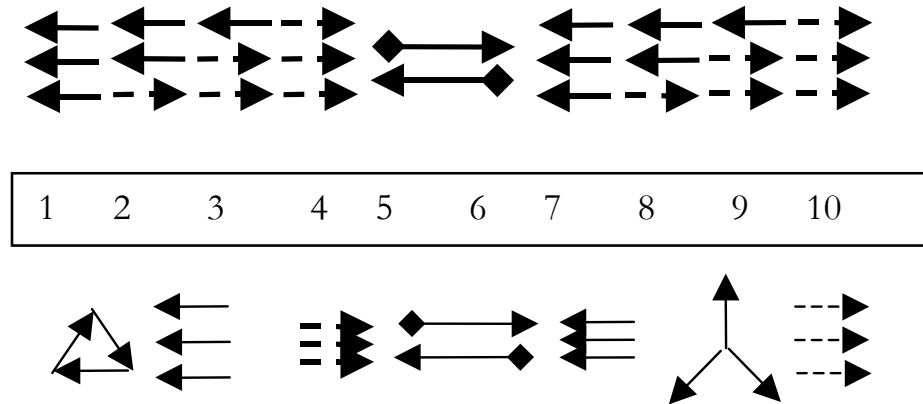

Fig: Axiomatic Cyclic Limit Of 10 Counts.

It is highly indicative that the observed complication is because the three modes of an interaction are directly related to the direction of the 3 axis. The solid arrows mark the original inward state and the dashed ones radiate.

## Secret Of Sankhya: Acme Of Scientific Unification.

The closed triangle show the simultaneous dense Thaama state while the radiating arrows show the radiant Sathwa mode. The mix of dashed and solid arrows indicate the number of axis that is not synchronised with the original state. It shows 10 distinct combinatorial states. Three counts for the closed triangle with 3 axis converged , another three counts for the 3 axis in radiant mode totalling 6 ways. Then there are four additional variants of inward & outward going combinations of parallel and antiparallel combinations. Two axis synchronise perfectly to reduce the interactive counts logarithmically when the value of a count is less than  $1 / C^{1+x} = 5e-13$  . Or about a femtosecond differentiates the synchronised from the non synchronised state as identified in Suthra 32 as a bonding action. Similarly  $1/C^{1-x}$  defines desynchronisation is complete and leaving  $1/(C^x)^2$  as the period in which the bonding or resonant or coupled state can exist. These three parameters have a fundamental identity in Physics and is shown in the axiomatic derivation section.

The essential point to note is that the tranfer of interactive parameters can act only along one axis albeit it may be bothways, within the duration of such activity. Sequences 1,2,3 & 4 and 7,8,9 &10 transfer the effects only through 5 and 6. In a confined region the 1 to 4 states represents the ingoing, centered and highly compressive states symbolised by the closed triangular set of arrows. Whereas the 7 to 10 are expansive being free to act outward again symbolically as an opened oot set of three arrows. However the constraint is at the interface of the transition state at 4 and 7. . The outgoing three axis to be constrained to act inward in a confined way through a double axis path of 5 and 6 that acts as a single channel by synchroniseng. Because of these two axiomatic and transcendental ratios of 'e' and '  $\pi$  ', any interaction between identical components in a confined or region bounded by other similar components, will remain in the Aikaantha state and

166

## Secret Of Sankhya: Acme Of Scientific Unification.

only transmit the stresses in a transmigratory mode following the 3 Guna interactive characteristics. Axiomatically and logically the components cannot move away relative to another unless there was freedom to move.

Since the substratum is a sea of identical components, there is no freedom to move along any axial direction. Hence the Aikaantha state is maintained by two values of  $e$  and  $\pi/10$  as a ratio. It causes the stress values to build up to a constant limiting value. Since the interactive reactions follow laws of self similar action, it can also be expressed as an infinite power series. The accumulated stress provides the potential to respond instantly to any change caused by an unbalanced interaction. It causes interactions to take place simultaneously. Mathematically defined as a coherent state, because space wise it oscillates symmetrically at the same nodal positions and cycle (or period) wise it is in synchronous step with previous cycles and forms the background state. It is a state in which all the components in the substratum oscillate periodically in locked step or timing. Hence it is an undetectable state as only a change from a standard state can be detected in relation to it. It is a self similar & synchronised state and is always in a balanced state. The self similar fraction  $x$  and its internal division adds up to one with increasing powers of  $x$  (representing fraction of unitary cycle) to any level.

Equation. S. 1.E.

$$\sum_n x^n = 1.618034 \quad \blacksquare$$

Though an Aikaantha state is depicted as a stationary state with a unitary value because of its coherent, synchronised and simultaneous behaviour, it can still be described numerically by the above equation to any level of

## Secret Of Sankhya: Acme Of Scientific Unification.

accuracy. If one state can be identified as having a real relevance with a value of  $x^n$  then the spectrum of possible states that have a relative harmonic or proportional connection can be identified within the unitary Aikaantha state. Since it remains in a stationary position and symmetrical state it cannot rotate or change its orientation relative to any point of reference.

It is an extraordinary state wherein all the stable states exist simultaneously and harmoniously all the time. It is a dynamic state that maintains the same stable conditions at the same positions all the time. It is a symmetrical state that maintains its symmetry all the time. It contains the same set of coherent vibrations in every location or point. As an example if an extremely small section can be broken off, it will contain all the coherent oscillatory combinations in this infinitesimal section from which the original information can be regained. It is a holographic state, described as an Andhatamishra state in Sanskrit or the equivalent of a tiny blackhole state.

Coherent states have identical conditions in a self similar and scale invariant mode everywhere simultaneously and also act in the same way. It is similar to a linear harmonic standing wave but in a 3 dimensional substratum. It is a cubical or spherical 3 dimensional harmonic wave functioning in an internal breathing mode where only the logarithmic index of the potential, changes or flips one up or one down to maintain a null difference between any adjacent state, periodically. The breathing mode changes the potential level by increasing or decreasing the power index by one unit and two adjacent levels cannot have an index level difference greater than 1. As an example:

Equation. S.1 F.

$$\begin{aligned} n &:= 6 & (1 + x)^n \cdot x^n &= 1 \\ x^6 + 6 \cdot x^7 + 15 \cdot x^8 + 20 \cdot x^9 + 15 \cdot x^{10} + 6 \cdot x^{11} + x^{12} &= 1 \end{aligned}$$



## Secret Of Sankhya: Acme Of Scientific Unification.

The internal shift of balance is a logarithmic value of one but it implies a simultaneous change of 10 units or a cycle. Hence internal changes can be simply identified by the logarithmic index as cyclic changes. Stresses internally tunnel or avalanche by changing the index values by one which means a shift of 10 counts as a simultaneous cycle. Such phase changes are beyond detection.

The individual state of components being identical to each other in every way and in a state of total internal freedom, vibrate in every possible mode and transmit and share these interactive oscillations in such a way that the locations of identical stress count values fall into regions of nested cubes (or spheres) in every cycle or period that constitutes the instant or duration of activity. It's speciality is that all variations are registered as a change in the static potential resulting in a phase or synchronisation difference and not by a change in linear velocity or its local position. It would seem to be devoid of motion but that is because the entire activity is due to the superpositioning of vibrations in the same location. It is a vertical increment in potential or decrease in the oscillatory-cycle interval as opposed to a horizontal activity like linear velocity. It is explained in Suthras 40 and 41.

Each axis has two oscillatory states with a periodic relationship of 1 and 2 or cyclic relationship of one and half, that would allow the nodes or turning points to maintain the same locations at the same cyclic rate of two. The incremental rate needed to maintain an expanded oscillatory cycle is  $(2^3 = 8) - 1 = 7$ . The true Aikaantha state that remains isolated yet its sum remains  $1/7$ , that ensures the spectral characteristics of Sathwic phenomeon. FM7 lays the foundation for the Purusha state.

Equation.S.1 G.

$$169 \quad \sum_N \left(\frac{1}{2^3}\right)^N = 0.1428571429 \quad \frac{1}{7} = 0.1428571429$$

## Secret Of Sankhya: Acme Of Scientific Unification.

The internal cycle is maintained by superposing according to the  $x$  series. The internal division can be extended to any level (FM5) and the coefficients in this series, similar to those in the binomial theorem, forms a Pascal triangle. (Shown in the axiomatic derivation section)

**Aathyantha.** It represents a state of endless activity or perpetual dynamism or interactions without end. Any cyclic time period will not end or cannot come to a stop because of the other three factors. In order to theoretically justify cyclic time periods of an eternal nature the axiomatic factor that would provide for this quality must be identified as a quality inherent in the substratum of space. If this quality does not exist then it becomes a certainty for one to predict the end of dynamism and state of non-existence. The existence of the Aathyantha can predict the continuation of dynamism which naturally leads to sequential or repetitive state of cyclic action.

It is a perpetually interactive state. It is cyclic, synchronised, in-step, recurrent and never reaches a limit that stops the interactive process. The first of three formulas shows that even if a polarisation factor  $x$  is summed up to infinite powers of index and for infinite time-duration the maximum potential will not exceed the kinetic or basic potential by more than  $1+x$  or the rate of expansion cannot go beyond the power of  $1+x$ . Therefore the self similar superpositioning count at any one location cannot exceed  $C^{1+x}$  at a single level and will be shown to be the Bhava / Ahankar value of a charge, in Suthra 32. It signifies a self induced assymetry in time that maintains the oscillatory state. Any cyclic interaction of 10 counts of one component with another similar one gives an instantaneous product of  $100=10^2$  counts and the maximum delay of a count in each direction of oscillation provides a total of 2 counts in 100 per cycle. Assuming

170

Secret Of Sankhya: Acme Of Scientific Unification.

that this delay continues ad infinitum as an endless series, then the uncertainty in an interactive count cannot exceed this count or stating it differently the cycle may be extended by this factor to bring about a balance in a free state at any.

Equation. S.1.H.

$$RS = \left[ \frac{100}{100 - 2} = 1 + \left(\frac{2}{100}\right)^1 + \left(\frac{2}{100}\right)^2 + \left(\frac{2}{100}\right)^N = 1.0204081633 \right]$$

displacement level. The value of RS is the natural or axiomatic delay in which the oscillations decay and remain snchronous.

The two parameters  $e$  and  $\pi / 10$  ,ensuring the Aikaantha state, have the quality of endless dynamism built into its derivation. The ultimate value of  $e$  is a constant, reachable only at an infinite rate of interaction.. Similarly  $\pi / 10$  is a transcendental number that tends to reach a constant limit at an infinite rate of interaction. Even then it only ensures the ‘circularity’ of the cyclic time variation thus ensuring a centering action. At its higher orders of interactive state, it remains centred or seems ‘static’. The two other states of Atho and Abhavath too must ensure the perpetual characteristics needed to sustain the cyclic state. The ratios of continued resonance and continued expansion in the two modes of simultaneous and sequential activity must be analysed and the appropriate factors derived. But before demonstrating how both these aspects of the field space support it, such parameters must be derived .

**Atho.** It is the non-symmetric space-like displacement and non synchronous cycle ( or period ) characteristics in the, resonant oscillatory background state that forms the dynamic base for all phenomenon. It motivates manifestation of phenomenon and as it is a state that exposes change, it can become detectable. Any incremental displacement at the elemental level has to be 2 as in EP3 But the spatial volumetric incremental

## Secret Of Sankhya: Acme Of Scientific Unification.

relationship varies by 7 in relation to the first one ( $2^3 = 8 - 1 = 7$  counts). Similarly doubling the radius provides 7 equal incremental spherical nested volumetric units. See diagram.

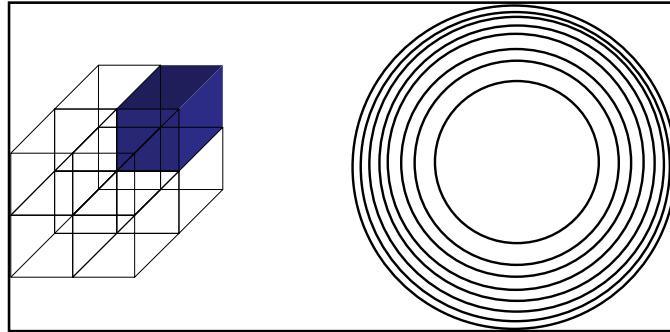

Fig: Doubling Spectrum By 7.

The rings expand radially as the cube root of 2 to 8. The cubic space too can expand by the same mode if synchronised on all 3 axis. The additive mode is shown with the blue cube as the primary unit. Equal oscillatory displacements in equal time periods produce a balanced state. However, here an interactive state is established wherein there is an inherent inequality either in nodal numbers, distance or time period between any two axis at right angles. Suthra 21 picturesquely describes the above oscillatory state as the dependant association between a blind man and his lame companion helping each other to get out of a pit that symbolises the potential well. A mathematical analysis of the very first vector state of a 1 by 2 gradient leads to some special features.

The term signifies movement or dynamic characteristics. When an interaction from an external source provides an impetus or motive force to move then such movement is temporary or it comes to a halt on the termination of that activity potential. But the definition of the substratum is associated with a fundamental state that is not dependant

Secret Of Sankhya: Acme Of Scientific Unification.

on external inputs and must necessarily provide such characteristics on its own or from its internal state.

. **Abhaavath:** It is the unmanifest interactive state that does not exceed the maximum potential, or expansion / contraction parameters. It implies that all interactions are contained internally in a balanced and synchronised state. It is a state where in all the dynamic parameters balance and equalise to retain the coherent state, perpetually and eternally. The Abhaavath state is a coherent, synchronised, simultaneous and symmetric interactive state where all exchanges are carried out internally. The exchanges involve stress transmigratory actions that do not involve any displacements. The nett cyclic exchanges result in zero relative displacement which ensures the maintainence of an unmanifest or undetectable state. The following mathematical expression symbolises and defines the unmanifest Abhavath state.

Equation. S.1 I

$\pi = 3.1415926536$	$RS = 1.0204081633$
$e = 2.7182818285$	$\frac{\pi \cdot x \cdot 10}{e \cdot RS \cdot 7} = 1$
$x = 0.6180339887$	

The ratio  $e/\pi$  represents the Thaamasic coherent state of simultaneity where all interactions act internally as a single unit. The e factor FM2 is a simultaneous count within a cycle and hence treated logarithmic mathematically. The  $\pi$  factor (derivation shown in FM4) represents the sequential interactive state within the Thaamasic domain. The ratio  $x / RS$  (FM,5,6,7) stands for the Raja resonant state of interaction that remains within a bounded region. The expansive logarithmic factor  $1/x = 1+x$  symbolising the equality of the interactive cycle in both the simultaneous and sequential increments. It is the starting point for all interactions that externalise .The 10 is the

## Secret Of Sankhya: Acme Of Scientific Unification.

simultaneous counts involved in an interaction that has each unit proportional to  $x/2$ , the axiomatic self similar ratio to maintain an interactive state perpetually. While 7 represents the sequential increment when an interactive period doubles. These form the principle rules to contain the Guna modes of interactions. All these factors are transcendental numbers thus ensuring their usage to Athyantha or unlimited number of interactive states.

The Abhavaath state is shown as a balanced interaction where the left and right side are perfectly equal and prevents any stress transmigratory states that could give rise to radiant and therefore manifest states. The expressions shown below define the Abhavaath state as a zero difference in count during an interaction. The transcendental numbers forming the ratio of simultaneous Thamaasic states being equal to the ratio of Sathwic sequential states.

Equation. S.1.J.

$$\left[ \left( 7 \cdot \frac{rs}{10} \right) - \left( \frac{\pi \cdot x}{e} \right) \right] = 0$$

The ratio of the Thamaasic Purusha spectrum is exactly equal to the Sathwic Moolalaprakrithi spectrum.

Equation. S.1. K.

$$\frac{Kx}{c^3} - c^3 \cdot my = 0$$

**Summarising the Logic.** :The Sankhya view that evolves out of the complete theory is that only vibrations are detected by the observer and all manifested phenomenon are aggregates or collective states of such vibrations on a fundamental base. Vibrations are actions and logically it must be caused by fundamental objects or components. Since only relative changes can be detected, any fundamental component that is not in a vibratory state

## Secret Of Sankhya: Acme Of Scientific Unification.

cannot be detected. Vibrations are caused by components in an interactive state or a cyclic state of colliding and separating that is common to all interactions and wave phenomenon. The interactions create three distinct modes of stresses. Collisions are compressive or inelastic. The resultant reaction is expansive or elastic. When the interacting components lack the freedom to move away the interactive state is maintained in a cyclic or shuttling mode in the same location in a resonant state. Vibrations can be measured if it has an oscillatory amplitude or displacement or a to and fro movement but if there is no space to move the vibratory action creates stresses or pressures. Such stresses transmigrate across the components in the three modes described earlier. This important Suthra lays emphasis that if the observed process of detection is dependant on vibrations, then fundamental space **must** contain components with those four characteristics described as states, which makes it function in a holographic way. That is all vibrations remain in fixed relationship relative to each vibratory point in a coherent and resonant state.

The axiomatic logic is that if vibrations are caused by interactions then the interactions itself can only be between objects, what ever these might be. The objects need not be defined as it only forms background. Since only vibrational counts of interactions are measured and compared dimensional definitions too are not needed. The following Suthras provide logically concatenating proof to show that manifestation is a holographic phenomenon. The Sankhya Suthras derive an unified theory that is self-similar, scale invariant, perpetual, self-organising, self starting and clock-time independent. The same laws apply in evaluating the galaxy, sun, planets, protons, electrons etc. The distance always varies with cyclic interactive period keeping C the perpetual oscillatory rate constant. And that is an axiomatic rate due to the action of vectors

175

Secret Of Sankhya: Acme Of Scientific Unification.

at the fundamental level. Therefor, the examples chosen remain in the realm of particle and atomic physics just as a matter of convenience.



**Suthra 2.**

The qualities of the substratum.

***dhrishtavadhaanushravik:***

detection process-standard or traditional

***sahyavishudhikshayaathishayayuktha: .***

certainly-distorted-attenuated-poor-resolution.

***thadviparithah: shreyaan***

hence-alternative appropriate

***vyakthaavyakthajnaavijnaanaath.***

manifest-unmanifest-coherent-kinetic-potential

**Meaning:** Standard methods of evaluation through detection are affected by distortion, attenuation and inferior resolution to details; but an alternate method that is totally satisfactory, is based on the principle of discriminating the basic and dynamic substratum into its appropriate components of the unmanifest, manifest, the self-potential and kinetic or dynamic potential.

**Explanation:** The terms Aikaantha and Aathyantha logically leads to the concept of the manifest and unmanifest and Atho and Abhaavaath to the differentiation of the dynamic state itself into an active kinetic state and a static potential phase. Suthra 1 established that all interactions in the substratum were coherent, balanced and internally contained.

The logic behind this suthra is difficult to comprehend. The concept of vector forces from polarisation is brought out through Guna logic in this suthra. Holistic analysis shows that detecting an object depends on the emanation put out from it; hence it can exist and yet not be detected because there is no emanation from it. If an object is detected at all it must be because of the emanation it puts out. Any information interpreted correctly constitutes

Secret Of Sankhya: Acme Of Scientific Unification.

intelligence. Information, that is not detectable, exists in a potential or static form. But when detected this information or signal or intelligence has to be in a state of relative movement, which is a kinetic potential. Traditionally, knowledge or information is communicated through the senses, primarily sight

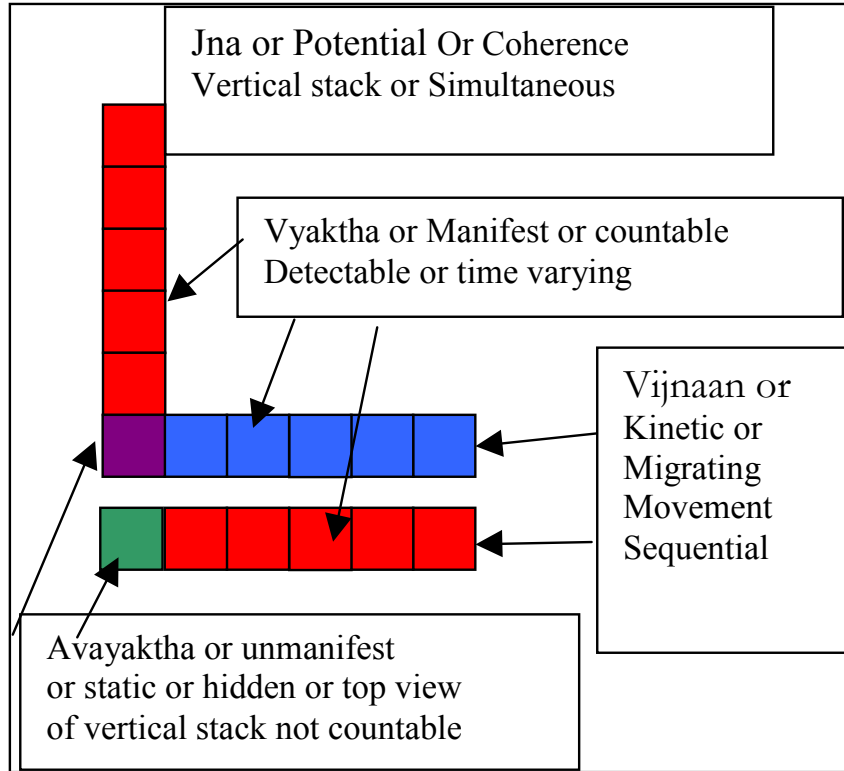

Fig: Discriminative Ability

and sound channels. Such an information process may be affected by adverse conditions and the knowledge so gained may suffer from distortion, attenuation and poor resolution. Like sight and sound are communicated by the respective forms of vibrations and distortion can be recognised when these are found to be different from the original. Weak or attenuated light and sound makes it difficult to understand the perceived or heard results. Poor resolution is when the grades of colour or tone cannot be differentiated. All or any of the defects shown above may

178

## Secret Of Sankhya: Acme Of Scientific Unification.

exist in the source of the information or the process of communication or in the recipient. It applies to instrumented systems as well, for the human sensory organs are considered to be natural instruments following the same principles of phenomenal behaviour.

Then how can one know when the knowledge so received is correct and can be relied on? Maharishi Kapila enunciated a method which enabled man to verify and ascertain the correctness of knowledge gained by himself and is based on the very first and fundamental set of principles that govern all the phenomenon experienced by man. The phenomenon may be manifest or detectable, or it may be unmanifest and therefore undetectable. Since phenomenon is dynamic the potential that causes it must be a part of the principle and the variations, (in the phenomenon) being the result of differences in potential. It conveys to the observer information or intelligence or knowledge of the process through its variations. Fig: 8 Clarifies the concepts.

If man can gain the ability to discriminate between these variations at the fundamental level where it operates, then he can be certain of the validity of the acquired information. Because by comparing and evaluating he can therefore comprehend the subtlest change. Why is phenomenon manifest or unmanifest (or detectable & undetectable) at the fundamental level? There is only one reason; and that is the ability or inability to detect the time-interval or duration of phenomenon Or the ability to discriminate at the finest or subtlest level can confirm the existence of the changes at the fundamental level.. As logically derived earlier, the components of the substratum are in only one singular state of – dynamic existence. If the movements or motion or oscillations synchronise, that is the time difference between vibrating components reduces towards what the observer considers to be zero or too small to detect, the phenomenon seems to be static, inert

179

## Secret Of Sankhya: Acme Of Scientific Unification.

etc. And such a time duration becomes his instant and a measurement yardstick against which all subsequent measurements can be made meaningfully. In fact that undetectable interval is the primary or first differential or the first unit of time interval , against which further measurements can be made.

Being unobservable, it unfortunately cannot used as a unit of comparison, as it has been pointed out that the ability to measure depends on an observable relative difference. However the next incremental unit must be detectable and that is at a level or measure of two units. Hence logically an absolutely important dictum, rule, law or principle is established that at the fundamental (unit) level, detection is not possible and that whatever phenomenon is detected or measured it must be of two or more units. (this is the basis of the advaita & dvaita concept; that is manifestation if detected, is always two (dvaita), dualistic or pluralistic in nature or the very process of detection requires a relational or relative background of more than one. Stating it in a negative terminology of not two (advaita) therefore means one.

Another important factor emerges when any change takes place in a dynamic substratum. Since the observer detects manifestation only due to time delay, then considering the undetectable time ratio of the substratum as " one upon one", the very next delayed ratio has to be "one upon two" due to an increase of the first unit against the apparently static background of the substratum. Therefore the first unitary change must produce the second unit, which can now be detected against the monotonous or unitary background state. One is an absolute number signifying the smallest digit (not zero) that is real and is a relational set or a fraction with both numerator and denominator having the same values. When the numerator has a value different from the denominator, the number set becomes a fraction or a ratio or a gradient wherein the static and

180

## Secret Of Sankhya: Acme Of Scientific Unification.

dynamic states differ in value, of the same type of units,( be it dimensions or time) or the synchronised state is lost.

The manifest and the unmanifest phenomenon is governed by the quality or effect of synchronisation. If a phenomenon or any element of manifestation is synchronised with the fundamental substratum (equal components) then the phenomenon does not manifest itself to the observer or it cannot be detected because the difference in time or movement is too small (less than a unit) to detect but the potential or motivation causing the undetectable activity is present (it exists) so it is a potential in a static form but unmanifest. When it is detected, it is because the time or displacement is large enough for the observer to detect but because it is detected as a relative movement it is now called a kinetic force or dynamic potential and is manifested. At this stage, if it synchronises with another similar phenomenon it is considered an integral part of the manifested phenomenon or an agglomerate in a simultaneous mode of action.

The non-synchronised aspects are the dynamic (kinetic) part of any manifested phenomenon and it is this last aspect that is normally called a phenomenon by the non-discriminating observer. Therefore a very important principle is evolved from the above: If the human observer seeks to detect the subtlest, smallest, quickest, weakest of phenomenon in his thinking environment then he must (repeat must) attain the synchronised or coherent state with the substratum, (of his cerebral system) because then and only then can he detect or be aware of the nascent change at its very source or starting point. Does it mean that when detection of phenomenon is not possible man's ability to acquire knowledge and understanding of nature is stopped? Then his intellectual capacity to theorise in the abstract and evolve principles through rigorous logic must come into effect and only then can he complete the process of understanding nature totally

Secret Of Sankhya: Acme Of Scientific Unification.

Even a minute change can be easily detected against a static background and such a synchronised (static) state of the mental environment can be achieved as indicated earlier by a simple process of being stress free; by not initiating any mental or other activity; by being passive; going with the tide of self-generated thought by neither pursuing nor obstructing it but by giving in and allowing it to take place for thought itself is an inherent activity of the fundamental field; a passive attitude of acceptance; a relaxed state of ease and comfort; a state of contentment that inhibits the generation of a motive to initiate activity ; a no-want state; a state where-in one has positively renounced the initiative to generate an act in thought, word and deed. The above is a state of harmony, synchrony and is an absolutely static or synchronised condition relative to the fundamental field. It is the Aikaantha-Aathyantha-Atho-Abhaavaath or self-similar, frictionless, unhindered (kaivalya), relatively static state of resonance. If from such a state, the most complex and subtlest form of mental inquiry is initiated then it has the best chance of generating a correct and appropriate solution. Suthra 4,5 and 6 define the parameters to mentally understand phenomenon. The process is detailed out in Appendix The Siddhi Meditative Process  
=====

**Suthra 3.**

Axiomatic 3 dimensional wave fundamentals of substratum.

***Moolaprakrithiravikrithirmahadhaadhhyah:***

root-oscillatory-coherent-harmonic-intense-primary

***prakrithyvikrithyah: saptha .***

fundamental-harmonics seven

***shodasakastuvikaaro***

sixteenth-approaching-radiation -

***naprakrithir na vikrithih purushah:***

neither-oscillatory nor-harmonics nuclear core

**Meaning:** The fundamental resonant oscillatory state is synchronised, coherent, resonant and stable; the first interactive oscillatory state is of maximum intensity of acceleration; then there are seven levels of coherent, harmonic and oscillatory interactive stages followed by an expanding radiation above a sixteenth order of the fundamental value; the nuclear core is neither oscillatory nor harmonically interactive.

**Explanation :** The fundamentals of three dimensional wave theory is defined in an axiomatic way. Oscillatory states are based on relational values. The ratio of a harmonic or synchronous vibratory state begins at half or two. Synchronous oscillations in step along all three axis will vary according to the volumetric value of vibratory counts. Since the counts are superposed or in- step or in-phase with each other it is described as a coherent state or Prakrithi state. If it loses its in-step or in-phase phase but the number of oscillatory counts per cycle remains the same it is in a harmonic or Vikrithi state. When it loses even the harmonic state it is a freely moving or Vikaro state of expansion, radiation or acceleration. The change

183

Secret Of Sankhya: Acme Of Scientific Unification.

from one state to another is conditioned by axiomatic ratios. If the coherent, volumetric state is one unit, then a change to 2 will require an incremental ratio of  $2^{1/3}$ . The difference between the two will then be  $1.259921-1=.259921$ . On the other hand if the value of on side of a cubical unit is one then a change to 2 will result in a volumetric ratio increase of  $2^3=8$  and the difference as  $8-1=7$ . These ratios can be used as relative units in a flexible way. Hence Prakrithi Vikrithi states increase by 7 when the radial dimension doubles. The change to a Vikaro state requires the  $2^3=8$  counts double and that is  $2^4=16$ , as explained in detail in Suthra 30.

Moolaprakrithi.(definition). The concept is that space consists of numerous elemental components. The components, described as representing a cube to maintain conceptual simplicity and axiomatic rigour, populate all space. Being free and numerous, all the elemental cubes interact with each other in Swabhava or self similar Guna modes as detailed in Suthras 11 to 14. The degree of separation from each other defines the interactive parameters. Eight adjacent cubes can define the small cubic space that identifies the interactive interval or gap in the central location where the eight corners of the cubes can meet .

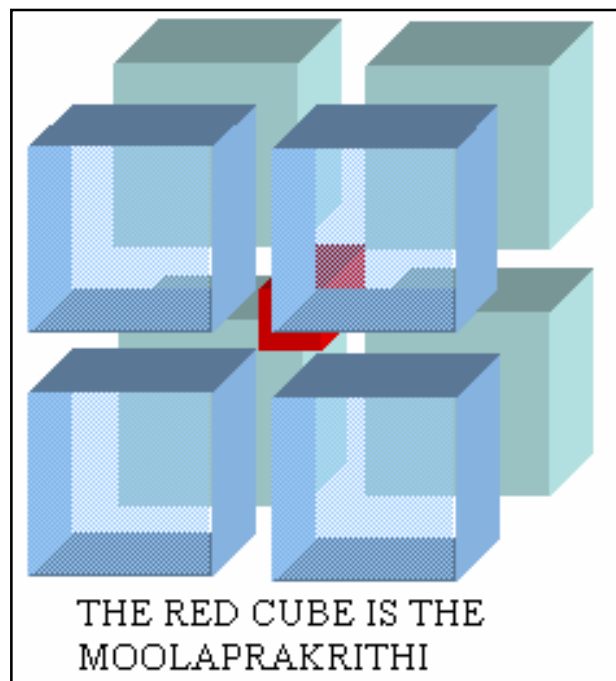



Fig: The Moolaprakriti Concept.

It is shown as the red cube in the diagram and displays the cubic form maintained by the 8 vibrating larger blue cubes. That red cube can be described in terms of interactive counts of vibrations in a cyclic-period, assuming that all the eight blue cubes interact in the same location. The size of the red cube has a specific numerical relationship to the larger cube. It can be numerically related in powers of 2 or  $2^N$  or  $(2^3)^N = 8^N$  etc. The larger blue cube can now be considered as just the combination of the smaller sized red cubes. The collection of red cubes act as a blue cube by vibrating together as a coherent synchronous, group displaying the quality of Thaamasic simultaneous activity. If the coherent and synchronised state of interacting or vibrating together simultaneously is disrupted then that position produces the effect of the red cube. It is a cube vibrating out of step or synchrony. It is a cube that does not remain in the same state or location as the rest and displays a different condition. It is the fundamental condition of commencement of activity called Moolaprakrithi. Moolaprakrarithi the red cube is not a cube but a state of a cube in an active state or a state different from the rest. It is a vibrating form that exists only because other vibrating cubes exist and is a holographic form. The meeting point of three axis shares a single point which in reality is cubic point. It is the fundamental concept of an unit of charge in Physics. **Purusha.** (definition). An important change of condition takes place at this interactive interface. The impact between two cubes can result in 3 states of interactive reactions as defined in the Guna Suthras. These are instantaneous separation on impact as an inelastic reaction

Secret Of Sankhya: Acme Of Scientific Unification.

of the Sathwa state. Or it may elastically vibrate and remain in a resonant Raja state.

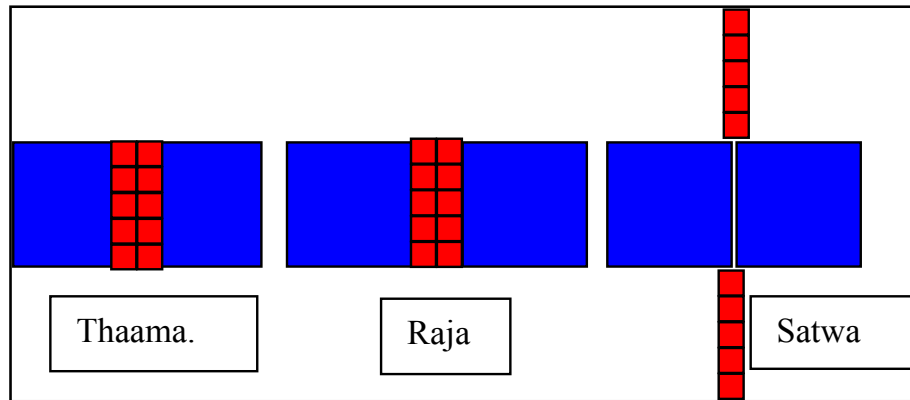

Fig: Moolaprakrithi To Purusha Transition

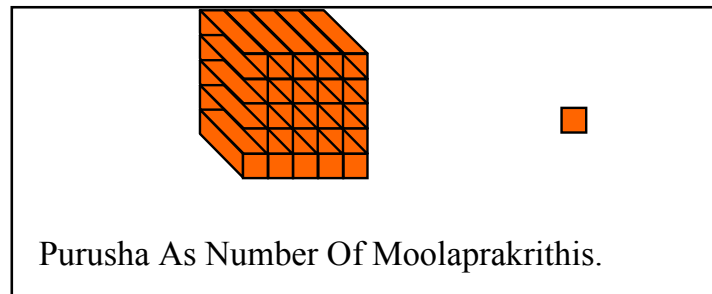

Fig: The Purusha Moolaprakrithi Formations

Finally it may combine together to attain a uniform, singular, synchronous and coherent state of activity as one larger cube in the Thaama state shown in the diagram. The Sathwa state shows the radiation of a set of 186

## Secret Of Sankhya: Acme Of Scientific Unification.

Moolaprakrithis as Vrithis (coherent particle states)) on sudden or inelastic collision. The Raja state shows the resonant harmony of two sets of Moolaprakrithis interacting simultaneously at the same rate as a bound state. The Thaama state shows the absorption of two sets of Moolaprakrithis in a higher state of activity as a superposing, compressing, or denser states.

If the red cube Moolaprakrithi is considered the elemental unitary state then larger cubes can be created as multiples of it as vibrant but coherent unitary states. The Moolaprakrithi is a cube of space in a vibratory state and the non vibratory state of this same unit of space cannot remain in that size because of the axiomatic nature of a Guna interactions. Hence the elemental components in space combine, agglomerate, or join together as a larger, self-limiting unit of space, **only which** can remain static or coherent or passive or unmanifest etc. There is a single Guna law that acts in identical ways at every agglomerate level of phenomenon. At each level there is the same proportionate limits of maximum and minimum interactive counts but the form and size may vary to attain balance at each level.

Saying it another way perpetual self similar oscillatory activity comes to a stop naturally only at the Purusha level. Hence it is called the Andhathaamshra or dark and dense state of superposed vibrations in space. The Guna principles explain why and how this has to be so due to axiomatic reasons. When the oscillatory state becomes undetectable by superpositioning of counts communication with that state is cut off and becomes an isolated blackhole state. Suthra ww shows that at  $1/(5 \times 10^{13})$  the ability to discriminate the interval between interactive counts disappears and it superposes on the previous count. It is the blackhole state in Physics. Therefore every unit of quiescent, apparently static, barely resonant and unmanifest unit of space is a Purusha,

187

## Secret Of Sankhya: Acme Of Scientific Unification.

massive, blackhole, potential, state of dormant, internal, stress transmigrational activity of the elemental components in space. Conceptually, it behaves exactly like the components deep in an ocean.

The natural drift of active states towards lower or reduced activity levels is purely due to the action and reaction counts not being cyclically equal. As an example if 20 interactions per cycle (ipc) unit interacts with a 10 ipc unit, the 20 ipc will move in towards the 10 ipc unit because for every 2 counts there is only one reacting count to attain a balance of counts. This is the fundamental cause of transmigration of counts between any two different count rate states. At the basic elemental level this drift of Moolaprakrithy counts towards the Purusha coherent states is observed as a gravitating phenomon. At intermediate levels this type of migration of counts display the Linga/Bhaava and Abiman/Ahankar changes in the Thaama-Raja-Sathwa Guna characteristics which represent the strong, weak and electromagnetic interactive spectrum Suthras 46 to 56 define the entire spectrum from the Andhathaamishra blackhole state to the fleetingly radiant Moolaprakrithi avalanche. At denser level fields in space the vapour, fluid and solid phase change states are caused by the Guna characteristics in exactly the same way..

Therefore the Galactic centre, the Sun, the planets, the hadronic nuclear states like the neutron, proton electron and all such forms that have a coherent internalised count state must seem to attract non coherent ensembles. The precise axiomatic mathematical reason for such transmigrating conditions are spelt out in Suthras 24 and 52 for the changes in state at the Thaama Raja (Quark-Hadron) and the Raja-Sathwa (Hadron-Lepton-Neutrino) interface respectively. The bracketed terms are only a broad indicator of the types of particulate forms, in a very complex spectrum of phenomena

## Secret Of Sankhya: Acme Of Scientific Unification.

The logical conclusion from the derivation above is defined in Suthra 62 .which declares that nothing is bound, released or transferred except the vibratory state. Expressing it in another way, solid, fluid and radiant states are due to the three Guna states in which interactive oscillations combine and remain as ensembles acting simultaneously in groups. . It leads to certain conceptual changes in the way manifestation can be perceived. The vibrating cubic form in a synchronised and coherent state represents a hologram like the Moolaprakrithi , except for the number of interactive counts acting simultaneously. Lack of dimensional classification does not detract from the accountability of space in terms of the holographic cube because both are of the same form in the same sea of components in space. The concept of dimensionality becomes superfluous. Assuming all cube components loose the freedom to interact, then there can be no gap at all in which case the error ratio will be the count relationship of one holographic cubic form of a Moolaprakrithi state to the sum of all cube components in space. This proof exists in the Suthra 68. It shows that if even one holographic Moolaprakrithi cannot exist then all manifestation as phenomenon must disappear.

**The Prakrithi Vikrithi spectrum of seven levels.** The Purusha and the Moolaprakrithi form the limits of the coherent and radiant states representing the Thama and Sathwa Guna states respectively. In between lies the spectrum of transition states The Prakrithi are the nodal or synchronous states that vibrate in harmony with the fundamental level. When vibratory distances or wavelengths expand by the same amount or double, the cubic count value rises to 8. It increases by seven different count rates. These are incremental states that exist as harmonics at distinct levels. Every time a wavelength doubles the incremental states rise by another 7 additional states with a different scale level of vibrations. Since these

189

## Secret Of Sankhya: Acme Of Scientific Unification.

are at distinct harmonic levels, the spaces or wavelength in between these nodes also have the Vikrithi vibratory states that do not synchronise with the fundamental.

While the Prakrithi states remain in harmony and are detectable as stable ensembles of vibratory states, the Vikrithi vibrations do not exist as stable ensembles. Vikrithi states are not harmonic and exist as a constantly and consistently changing state that may harmonise momentarily with other states. While Prakrithi states combine by harmony or synchronous-oscillations to display higher density, mass, energy, force etc at specific locations or intervals, the Vikrithi states display the changing states due to non synchrony and non coherence. In Physics the Prakrithi states depict the Thaamasic fermionic characteristics of spin half particles while the Vikrithi displays the Rajasic bosonic form of spin one particles. Though Sankhya does not refer to these states as particles but as a mixture of the three Guna oscillatory states of spatial components. The Vikrithi being the in between discordant states of the same Prakrithi spectrum, it too has 7 additional levels of vibratory states with every doubling of a distance or wavelength etc. although not a stable and detectable spectrum. This spectrum creates transcendent, fleeting, momentary, unspecified phenomena that are difficult to classify.

Though the Moolaprakrithi in action is similar to the Vikrithi state it cannot be termed as such because all other stable states are exactly in step with it. Because every phenomenon is described in terms of the Moolaprakrithi count value. there is no need for dimensionality. Since it is the smallest possible state of activity it forms the accurate unit of an Universal accounting process.

All measurement or detection is in relation to the basic state. Krithi is a cutting or sudden dividing action and gives the vibrations or oscillations the quality of a square wave, not a smooth or slowly changing quality like a

190

## Secret Of Sankhya: Acme Of Scientific Unification.

sinewave variation at the basic level. Interactions between inelastic objects can only display a sharp cut off or period of separation. It implies a high frequency or high vibratory rate per cycle and small or fine displacement or wavelength. At the point of balance between two different rates, the difference must be very small, both displacement and rate wise. This point is identified in Suthra 32 that pinpoints fraction of a cyclic count rate at which two interactive countrates are considered to be of identical value.

Avikrithi means a superpositioned state of oscillations of a basic or fundamental rate and does not contain harmonics. Such a condition implies that the superpositioning is carried out within the cycle or the time factor is less than unity or the ratio of radial displacement to velocity is less than one. The vibrations or oscillations are contained within a boundary and are coherent; that the rate is the same in all directions and the displacement of the vibrating boundary is synchronised and acts in the breathing mode and its centre of action remains stationary. It is not an accelerative state. It is a three dimensionally harmonious state. Its rate of vibrations forms the ground state and is maintained at the same rate due to an axiomatic characteristic.

An oscillation that has an equal inward and outward period of interaction or half of the total cycle. It remains stable and it defines the Moolaprakrithi state. It is a standing wave and must have time or displacement equal to  $\frac{1}{2}$  a cycle or distance. It is an axiomatic state in which all parameters are self similar which is a Swabhava state. It is not a detectable state as the nett displacement is always zero. Therefore at the fundamental level even though the Moolaprakrithi activity sustains the balance there is no detectable reaction to measure or observe. Space though full of activity does not display unbalanced reactions below an identified level.

## Secret Of Sankhya: Acme Of Scientific Unification.

The addition or combinations of oscillatory states follows axiomatic rules, that is, a new state is created by joining with an existing state, to expand acceleratively. The prakrithi or the spectrum of oscillatory states, divides into avikrithi or harmonic states that are stationery or have nodal and antinodal positions. Nodal harmonics are integer dependant and all rates are integer based but the ratio or gradient of a change are shown as fractions. These states have 7 nodal levels for the following reasons. The stable oscillatory state can change from its fundamental state of 1 to 2 and in all three axis it equals  $2^3 = 8$  and subtracting the first or primary prakrithi state leaves 7 nodal levels of harmonic states in a complete cycle of 8 nodal combinations. Similarly internally the the sum of inward going harmonics is  $1/7$ .

Therefore this Suthra lays down the algorithm for all future relative measurements in a cycle. The seven levels are captive and they cannot be separated in a spherically harmonius cycle and it must be realised that any measurement must take cognisance of this basic factor. The spectral density of seven harmonic levels affects any change from one level to double that level or an increase in ratio of 1 to 2. At the basic level it is of the largest magnitude . The moolaprakrithi is stable and forms the first internal level but the prakrithi – vikrithi polarisation to the next level gets externalised but still remains stable for the following reasons. The later Suthras will show that an interaction on colliding or obstruction of the vibratory state, superpose or add instantly or the output sum becomes a product of the two values. When balance is attained by separating in a sequential or periodic mode the value divides into equal halves or is additive. If the division is not equal then there is movement of nodes towards the lower value state. Any interaction is direction dependant along any axis and any colliding action between the vibrating components can increase the rate of change from

192



Secret Of Sankhya: Acme Of Scientific Unification.

1 to 2 as  $2 \times 2 = 4$  but the captive value of  $7 + 1 = 8$  is still larger than 4 and the level of activity is not enough to radiate or move away. The next level is reached when either one axis or a synchronisation of 2 axis has nodal value of 4. Then an interaction between two adjoining states will have a product of  $4 \times 4 = 16$  which then can separate in equal distance or time cycle of  $8 + 8 = 16$  and still remain balanced. When 16 is exceeded, movement away from centre commences or the centre of action drifts or radiation of vibrations takes place. The graphic presentation makes it clear that in a count rate of 10 per cycle the combination of increments yields  $8+8=16 = 4 \times 4$ . The expression for adding incremental rates that can be stable or divisible by 2 is  $(n \times (n+1)) / 2$ . This method eliminates the recount of a cube in two or three axis synchronisation and the cube is the equivalent of a point in space or a node.

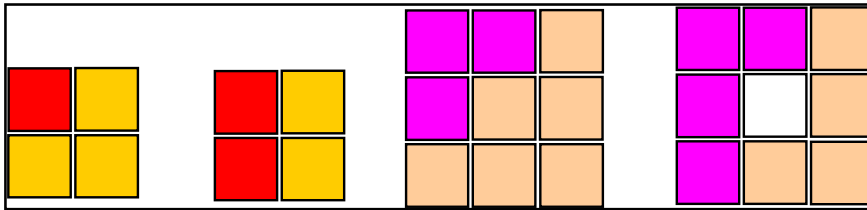

The stable combination =  $1 + 3 = 2 + 2 = 2^2 = 4$

The unstable combination =  $3 + 6 = 4.5 + 4.5 = 3^2 = 9$

The expression  $(n^2+n) / 2$  provides stable combination.

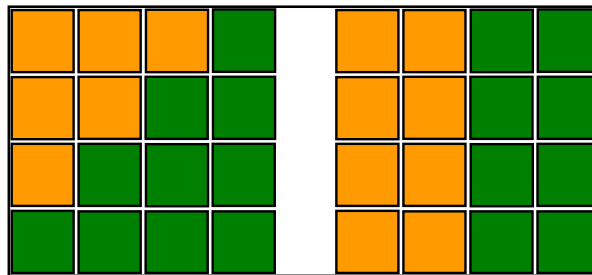

Fig: Aggregation Of Space Components.

Taking a series of n that takes an external incremental unit, gives the values of cunts as  $1+2=3$ .  $3+3=6$ .  $6+4=10$ .  
193

Secret Of Sankhya: Acme Of Scientific Unification.

10+5=15. 15+6=21. 21+7=28. 28+8=36. 36+9=45.  
45+10=55. etc

The combination  $6+10 =16= 8+8 =4^2$  is stable. When balanced it is stable else there are stress currents in both direction that shift the nodes. The left combinations are stable only at a gradient of 1 in 2. The combination of incremental harmonics can remain stable if divisible by 2 to maintain the standing wave relationship. The right side combine with similar states in a coherent standing wave Prakrithi relationship. (The periodic table in chemistry and the quark spectrum in particle physics follows the same rule and details are shown in Suthras 46 to 50)

**Vikaro** (definition). Is the state of unsynchronised, unbalanced or ecelerated activity and it commences from the 16th. nodal level. The next level of expansion or increase in harmonics occurs in the next cycle. The stable or fundamental or coherence state described by cubic formulation can only be upset by an interaction with another cubic form but the reaction from the interaction polarises according to Guna laws. Hence the cubic state of third power increases to the fourth power interactively to launch the Vikaro accelerative or radiative process.

**Purusha. Axiomatic derivation.** The core Purusha position is in a densely superpositioned state. It is kept in balance by the moolaprakrithi activity. The standing wave nodal position is maintained because of the reaction from the components oscillating at the same stable background rate C.

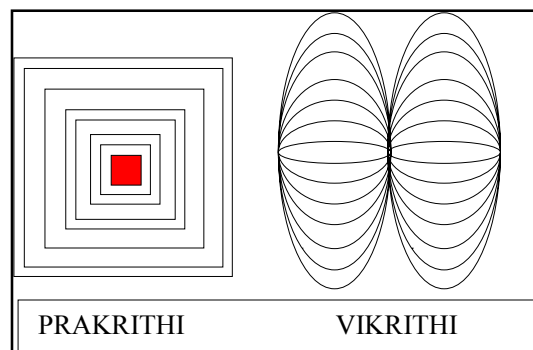

Fig: Prakrithi Vikrithi Nodes In Purusha.

But if it is less, then the nodes drift towards the core or centre to attain a stable nodal position. The nodal spacing depends on the maximum superpositioning density. Density along one axis is shown. Equation.S.3.

$$k = 2^{\frac{1}{3}} \text{ cyclic\_expansion} = 10^{1+x} \text{ sequential\_expansion} = k^8$$

$$RS = \frac{10^2}{10^2 - 2} = 1.02040816 \quad EP7 = \sum_n \left( \frac{1}{2^3} \right)^n = 0.142857$$

$$\text{Purusha} = Kx = \left[ \sum_n \left( \frac{1}{2^3} \right)^n \right] \cdot \left( \frac{10^{1+x}}{k^8} \cdot \frac{10^2 - 2}{10^2} \right) = 0.9149879388$$

The Purusha node is a cubic point in reality. Suthra 30 defines it.

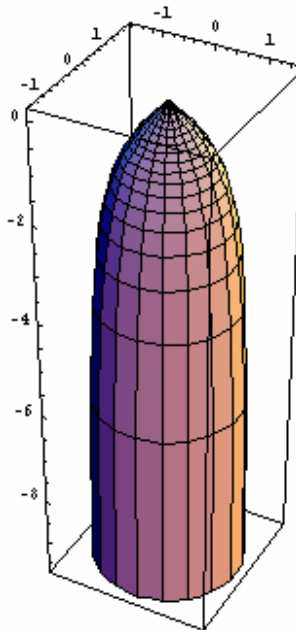

Secret Of Sankhya: Acme Of Scientific Unification.

Fig: The Purusha Andhathamishra Form

The Purusha combines both Prakrithi and Vikrithi to harmonically remain in a coherent state. The stress due to interactive density is maximum and the red square in figure 12 above shows it but its not to scale. Taking that point as a real unit and dividing each side by two gives 8 units. Continuing it endlessly results in extending the cyclic period of divisions as an instantaneous or logarithmic sum within one cycle. The value is arrived at FM7. While the first division gave the value as  $(1/2)^3 = 1/8$  the EP7 shows an increase to  $1/7$ . Applying the Guna rules of simultaneous, sequential and resonant interactive states, results in FM9 values. The conceptual shape of the Purusha Linga state Kx in the Thaamasic state of coherent interaction is shown in Fig: 14 The stress lines show the variation from the stage when all the three axis synchronise to a point and gradually expand to the Mahad Prakrithi Mps form. The Purusha state defined as the sum and product of coherent activites is strictly a process of dividing by 2. The proof that concept must be correct is given by the sum of all the Vikrithi states. As defined before the Vikrithi is the non synchronous state of the same number of vibrations at the coherent nodes. FM11 gives the value called a Catalan in mathematics. There is a very accurate reason for the small difference between the Purusha Kx and the sum of Vikrithi Vk values. It is explained in the 68<sup>th</sup> Suthra, but the RS prakrith state limits the Kx value to balance with all the other parameters. Equation. S. 3.A.

$$C = 10^{\frac{2}{\sqrt{(1+2^2)} - 2}} = 2.9657596692 \cdot 10^8$$

$$\text{Moolaprakrithi} = My = \frac{Kx}{C^6} = 1.3446202249 \cdot 10^{-51}$$

$$\text{Vikrithi} = Vk = \sum_n (-1)^n \cdot (2 \cdot n + 1)^{-2} + 1 = 0.9159656254$$

**Moolaprakriti. Axiomatic derivation.** The Moolaprakrithi is the smallest interactive component of the Purusha. Since it is the basic or fundamental state and forms a unit of interactive time cycle or inertia count with every state, it has a number of ways of derivation that confirms its extremely small value relative to the Purusha. The cycle of 10 counts increases its value by breaking its coherent and synchronise state and attains the value of C. The velocity of light in Physics has the same number value if the wavelength is defined as a metre and time of a second is extended by a factor 1.010845. The ability to derive the equivalent of the velocity of light that was made into an universal constant and limit arbitrarily, reinforces the logic of Sankhya, for here it is an axiomatic constant of interactive vibrations between components in the space. C corrects the experimental value by the doppler shift created by the Galactic transfer velocity in space.

In Sankhya, components in space do not and cannot travel but only stresses created by interactions can transmigrate. The combined or agglomerate form is maintained by vibrations caused by interactions and only such stresses transmigrate. Hence the concept of a velocity in a sea of components in space cannot be accommodated but the transfer of stresses as phase transmigration velocity is justified. The holographic vibratory state remains at a constant rate C in FM12, when coherence is broken and the value changes according to Guna laws during the cyclic interactive states. It will be shown in later Suthras that interaction rates remain at 23.23 and 259.55 vibrations per cycle as the internal coherent and surface resonant rate of transmigration of stresses respectively. They correspond to

## Secret Of Sankhya: Acme Of Scientific Unification.

sound and terrestrial quake velocities.  $C = 296575966$  is reached when coherence breaks at a gradient of 1 by 2.

In an interaction between two components three modes of evaluation is followed. The vibrating cubic form of a component of space in a coherent state is numerically equal to  $C^3$  counts per cycle. A point to note is the cyclic interval is  $1/C^3$  if all three axis are not acting together or operate in phase or in step. It changes to  $1/C^2$  if two axis synchronise and  $1/C$  if all three synchronise into a coherent state. The disappearance or vanishing of  $C^2$  in two stage of synchronisation of axis is the cause of the observed difference in mass-energy or charge-potential or strong-weak-electromagnetic or solid-liquid-vapour or hadron-lepton-photon polarisation phenomenon in Physics.

The Thaamasic mode of internal interaction is  $C^3 \times C^3 = C^6$ . If a number of component forms are combined then the six sides interact with its opposite as  $C^2$  and all three axis acting together results in  $(C^2)^3 = C^6$  again. This is the maximum number of interactive states that can be created within a cycle. Therefore the Moolaprakriti must logically be the  $1/C^6$  fraction of the maximum period of the Purusha coherent state. My is the smallest possible interactive value taking C as the value of the resonant state. The relevance of the Moolaprakrithi to all aspects of cyclic phenomenon is highlighted in the figure 'Closed Substratum of Space' on page 82. The derivation of all the six stable states linked to the Moolaprakrithi value by C is an exquisite proof of the profoundness of Sankhyan logic shown the section 'Axiomatic Mathematical Derivations'.

### **Prakrithi Mahad Saptha. Mathematical Derivation.**

The Prakrithi states are nodal ensembles that retain their stable positions while changing from the coherent to the resonant positions. All these are changes in the same locations that interact as a simultaneous group and expand to the stable level. The interactive states in this spectrum

198

## Secret Of Sankhya: Acme Of Scientific Unification.

of seven levels are at the core level . The Mahad state changes are brought about by a break in the coherent state where all three axis are in step and the count is just  $C$  even though the  $C^3$  is its real value. Here the vibrations or oscillations occur in the breathing mode and only the stresses transmigrate as internal phase changes hence  $C^2$  is hidden as superposed counts.

As the angular cyclic interval widens between any two axis the breathing mode counts change from  $C$  to  $C^3$  in stages. The superposed state signifies the potential phase or the Linga mode of interaction. The progressive angular widening changes the Linga potential into the Bhava form of kinetic potential. It changes the breathing mode to a radially widening spinning mode of interactive balance. Evidence of changing time periods are introduced in the region. The polarisation of Linga into the Bhava phase as sequentially changing location of interactions is seen as spin. When  $C$  has broken its coherent state by increasing  $C$  through  $C^2$  to its basic level of  $C^3$  the process reaches its stable state at the expanded end. During this complex change, superpositioning density, interactive time cycle, radial counts and inertia (or mass) have changed **simultaneously** in a perfect process of self similar ratio of exchange without **radiating or absorbing counts in the same location.**

The Mahad Prakrithi changes to Saptha Prakrithi state as transmigratory stress change process in the same location. It can be visualised as twisting and untwisting type of oscillatory interactions, in a stable state. Identifying it in Physics the Mahad is the Planck Mass state and the Prakrithi Saptha the Neutron in the hadronic spectrum. The quark levels change through seven levels of interconnected states identified as being in asymptotic freedom. All these interactions are axiomatic because the motivation comes from hindering the synchronisation process of absorbing counts. It is the perfect yo-yo effect

199

Secret Of Sankhya: Acme Of Scientific Unification.

that is sustained only because there is no physical movement but transfer of stresses at resonance through **transmigration**. Equation. S 3. B.

$$K_x = \left( \frac{1}{k^8} \right) \cdot \left[ \sum_n \left( \frac{1}{2^3} \right)^n \cdot \frac{10^2 - 2}{10^2} \right] = 0.9149879388$$

$$M_{ps} = \left( \frac{1}{k^8} \right) \cdot \left[ 10^{\sqrt{(1+2^2)} - 2} \right]^{-1} = 2.2036944538 \cdot 10^{-8}$$

The rigorous derivations are shown in the section on axiomatic mathematics but the relevant states are derived here to enable understanding of a most phenomenal process that establishes the power house in space. The Mahad Mps value is derived by allowing the 7 RS resonant state, that maintains the coherent Purusha Kx state of balance, to expand to C . FM13 shows the Purusha Kx change to Mps by an exchange of the expanding parameters C/(7 RS) to its axiomatic limit. Value of C an expression from FM 12, is shown in FM13 to highlight at a glance the spectacular change of a blackhole state Kx to its interactive commencement state of Mps. The same change shown in symbolic form highlights the equivalence in a traditional form.

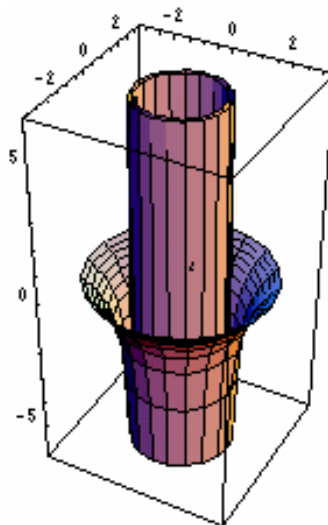



Fig: The Linga-Bhaava Polarising Form.

The Purusha Kx oscillatory state depicts momentum confined as internally transmigrating stresses. That equivalence is confirmed by the Planckmass momentum of Mps into C, the velocity of light. This interface Fig. 14A called Andhathamisrah-Moha changes from a coherent potential state of interactive stresses held as ‘confined momentum’ to a dynamic momentum of the Mps Mahad mass. Here is an extraordinary proof that the largest momentum Mps C is equal to the resonantly oscillating stresses in every Purusha blackhole in space as Kx 7 Rs. This equivalence of static momentum or dormant potential to dynamic momentum is the equivalent of entropy in Physics, which enumerates the modes of change possible in such a state. It provides the mechanism for absorbing interactive counts from the C state to the 7 RS coherent state. Therefore radiation is absorbed in space, hence photons must decay in  $10^{18}$  interactive displacement of 1/10 of cycle or 0.6283. Further, the Mps value is derived in 5 different ways and give identical numerical value which removes any doubt about its statistical significance.

PM the Prakrithi Saptha or the 7<sup>th</sup> harmonic level of the Baryonic/Hadronic spectrum is identified as a stable nuclear state. Its generic derivation is shown in FM14.

$$201 \quad \text{PM} = \frac{\left( \frac{\sqrt{1^2 + 1^2 + 1^2}}{2^n \cdot A_n \cdot 2} \right)^3}{\left[ \frac{2}{10 \sqrt{(1 + 2^2)} - 2} \right]^3} = 1.6744231791 \cdot 10^{-27}$$

Secret Of Sankhya: Acme Of Scientific Unification.

Equation S. 3 C.

Comparison with FM12 exposes the change over from the Mps coherent boundary to the synchronous limit. PM a hadronic state behaves in Neutron / Proton modes depending on its freedom to act. The PM state is a  $C^3 / P_x$  count in space, the perpetual and axiomatic internal oscillatory state. It cannot decay but all other states decay into this state first. Because  $P_x$  is the axiomatic coherent, 'rest' state of a cubic unit of holographic space. This axiomatic constant figures in many interactions at the fundamental level. The actual PM state cannot be detected as it is in a coherent state. FM15 shows the perfect balance. Just as a spherical photon cannot be detected, so to the PM, Mps and  $K_x$  states Any difference in counts between any two axis sets the  $A_n$  vector ( see FM4) to balance by resonance. It forms a potential well or the negative gradient in the normal  $C^3$  count The  $P_x$  factor keeps the surface in a spherical form of vibrations in the Equation. S.3.D

$$P_x = \left( \frac{\sqrt{1^2 + 1^2 + 1^2}}{2^n \cdot A_n \cdot 2} \right)^3 = 20.9479860976$$

$$\frac{K_x}{C^3 \cdot PM \cdot P_x} = 1 \quad \frac{K_x \cdot 7 \cdot RS}{C \cdot Mps} = 1 \quad \frac{C^3 \cdot my}{P_x \cdot PM} = 1$$

breathing mode for all three axis have  $C / P_x^{1/3}$  counts that provides lower rate to keep PM surface boundary in the form of a potential well. The Linga / Bhava interfaces at the PM boundary is stable because no counts are radiated

202

Secret Of Sankhya: Acme Of Scientific Unification.

or absorbed. A critical analysis of the mutual relationship is given below with a diagram.

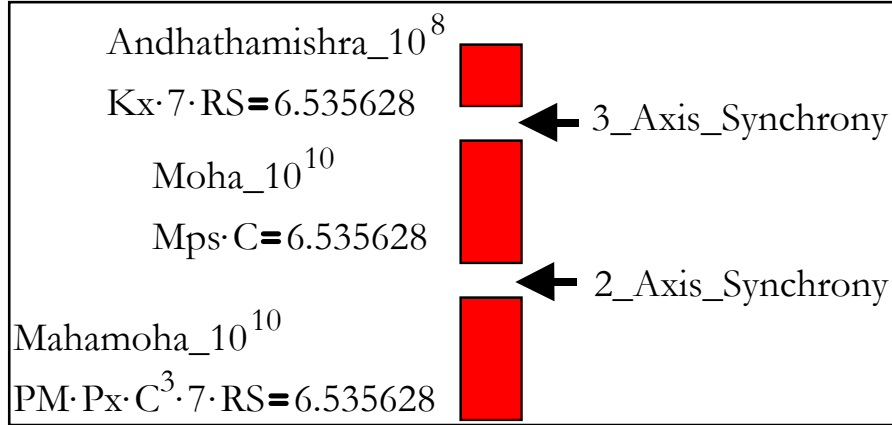

Fig: The Thaama Intreraction In Linga Mode

The Kx, Mps and PM are three phases of the Thaama Linga coherent potential in a centred state and all are equal to a constant. Kx is the Andhathamisra state at an interactive internal stress transfer rate of 7 RS counts per cycle.

Here the Purushha component in space is in its fundamental isolated and free state. It is the ground state where FM12, Kx formulation exists. Therefore all higher count rates drift towards such centers which behave as a blackhole state. Why do interactive counts drift? The diagram Fig:14. shows how the higher interactive count drifts or gravitates or transmigrates to a stable lower count rate.

The  $5+5=10$  maintains the same central meeting point always. The 11 to 14 counts show the incremental drift of the meeting point towards the 5 count rate.  $5/10$  is 0.5 but  $5/14 = 0.357$  The reason why count rates drift to the Kx level can be explained by another method. The Mps count is accumulated C times and held

together as a simultaneous ensemble which then has to be interacted only 7 times in a cycle to equal the total Kx count value. Momentum conservation concept imposes

## Secret Of Sankhya: Acme Of Scientific Unification.

the rule that larger the count value as a single ensemble, the slower is the rate of interactive transfer. It takes 8 cyclic changes or  $10^8$  counts to shift to the lower level. Again if 5 counts per cycle takes  $1/5$  of the cyclic period to

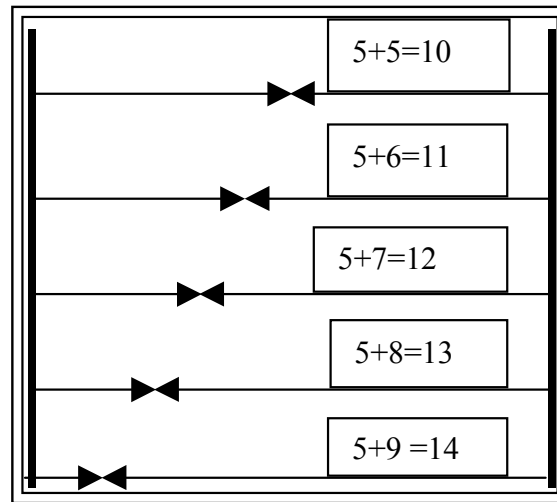

Fig. Stress Transmigration.

reach a point, then 10 counts per cycle sends 2 counts in the same period. Hence the essence of the principle is if the counts per cycle match exactly then the meeting point remains in the same position or else there is a change in interactive location. Two sentries keeping watch across a doorway will always meet at the centre if they take the same number of equal steps. The moment a step or rate becomes unequal the process of separation starts. This is the **only reason** for transmigration or movement of vibratory or oscillatory states that represent stress in any of three forms. Filling a box with 100 cubes one at a time takes 100 operations and the interval of time for each action takes  $1/100^{\text{th}}$  of the whole cycle. If 10 cubes are transferred simultaneously as a group in each operation of  $1/100^{\text{th}}$  of a cycle,  $9/100^{\text{th}}$  of the remaining part is an idle period in which no transfers would be detected. Therefore simultaneous events have to be treated differently and cannot be averaged. The Laser and Maser types of

204

## Secret Of Sankhya: Acme Of Scientific Unification.

coherent phenomenon with unusual results underline this concept. Coherent radiation of energy is in pulsed form.

The Mps at the Andhathamisra-Moha (blackhole-boundary) interface interacts in the Raja Linga mode at C counts per cycle. Though cubic space counts are  $C^3$  / cycle the potential is reduced to C because 2 axis are synchronised at this interface and hides the  $C^2$  counts. Recall the experiment when ten claps count as one clap, when perfectly synchronisously. In this state stresses transmigrate and act in the sequential prakrithi mode and is the equivalent of momentum without any movement or static stress. If there is movement the two axis synchrony will be broken and the Prakrithi state will be destroyed. The resonant C counts per cycle at a cyclic period difference of 1 to 2 remains centred and thus creates the largest inertial state ready to transfer stresses. The proof is shown in the axiomatic derivation section where the displacement counts per cycle is exactly  $7/My$ , proving that the Moolaprkriti is not only the smallest unit of activity but also the highest eccelarative unit in the Universe. The counts at this interface transmigrate to Kx at 7 RS when the rate C is exceeded. The potential drop at this interface is  $C/7$  RS counts per cycle..

The Prakrithi Saptha PM also acts within the Thaama state and operates at the Moha- Mahamoha interface. It expands as the change in the coherent state breaks the symmetry. The density or the superpositioning of counts reduces to an axiomatic cyclically interactive state of synchronous activity. It attains the equivalence of the normal state of components in the  $C^3$  state of a cube oscillating in the breathing mode. In the breathing mode only the stresses from confined interactive activity transmigrate internally to maintain balance but there would be no detectable change in the external state. For example while inside the Sun there is intense activity but the shape of the outer surface remains the same. All the interactions upto this point have

205

Secret Of Sankhya: Acme Of Scientific Unification.

been internal, self similar, perpetual and unmanifest. It is still in the Thaama interactive state operating in the Linga mode of simultaneous activity. This interface is in a complex interactive state that breaks its coherent, simultaneous Thaama mode to enter the sequential and radiative Raja and Satwa interactive modes. A detailed analysis of the complex changes are shown diagrammatically and axiomatically in Fig.15.

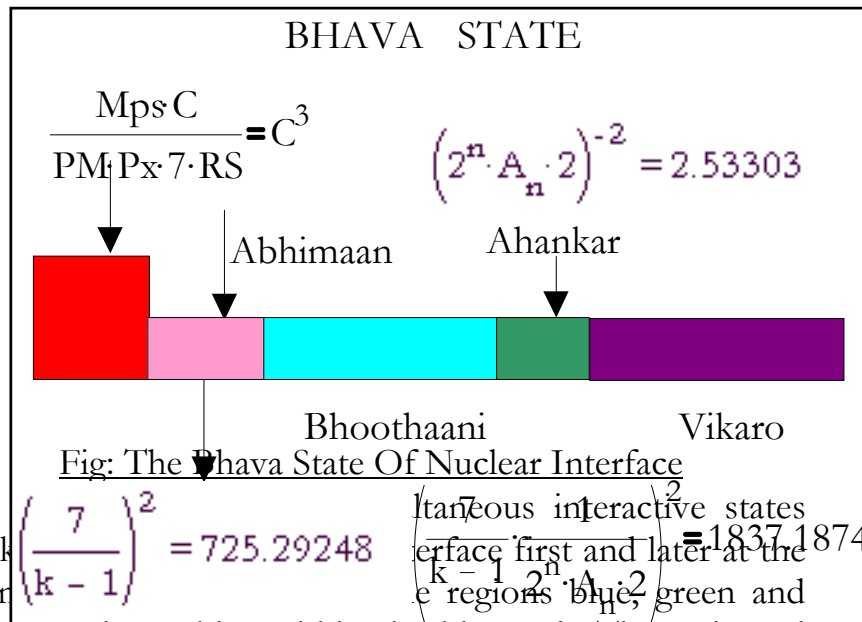

Within the blue only Thamasic and Rajasic Prikrithi harmonic states remain stable and observable. The Rajasic Vikrithi non synchronous states are not stable and only fleeting, momentary and transcendent phenomenon can be observed, detected and interacted with. The Sathwic states are free, expansive and radiant states that become observable as a reaction. The Sathwic radiative states form the resonant decay states

## Secret Of Sankhya: Acme Of Scientific Unification.

that interactively get absorbed into the substratum the moment they are accelerated beyond C because the coherent and quiescent Thamasic Linga state of the Kx/Mps/PM spectrum are always at C . Recall C<sup>2</sup> synchrony hides in C<sup>3</sup> to maintain only C counts. As a result of two axis synchronising, space cannot be radiant because it is in an absorbing state. The absorbing action is only possible in the coherent state wich automaticall reduce counts by synchrony. Again recall Kx is idling at 7 RS counts per cycle and therefore it has a prodigious capacity to absorb all counts above 8 per cycle. Extremely long waves are involved in this spectrum.

The Abhimaan interface between the C<sup>3</sup> Thaamasic and a spectrum of Raja states varying from C<sup>2</sup> to C in cyclic

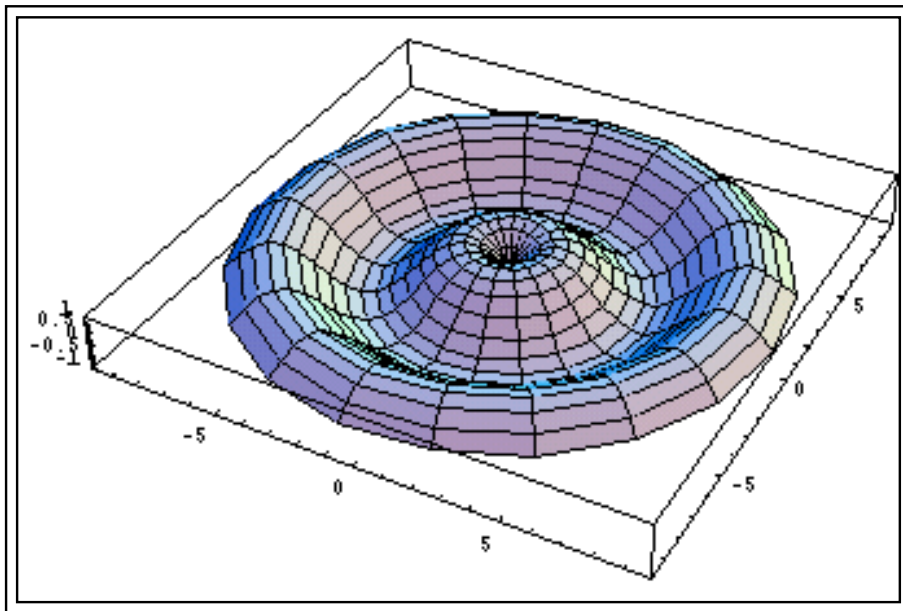

periods

Fig: The Abhimaan Potential Well .

extending over 13 billion years, forms an unusual junction or transfer point. Two opposite locations of the Abhimaan gap must be dealt with synchronously but not simultaneously. It means the interactive event in the Raja Abhimaan interface need not be found in the same

207

## Secret Of Sankhya: Acme Of Scientific Unification.

location. As an example though the distance from the moon or the sun remains approximately same, the orbiting bodies keep changing its angular locations according to certain rules.

The concept of spin does not exist in an interactive environment but sequential displacements may seem to follow a

curved path in a period. Current Gravitational theories look at the phenomenon as isolated from the coherent stresses in space whereas Sankya theory shows that disturbance of the restful or coherent state of the substratum creates gravitational and or related activities. All manifestaion is a local event because the maximum rate of power generation is vested in every coherent point in space and disruptive signals trigger action locally. The blue Boothani spectrum forms the magnetic or superposed count section in the resonant Raja state. Crossing the green Ahankar interface the purple Sathvic state commences as a radiative or accelerative transmigratory mode of Vikaaro. It covers the radiant photonic spectrum upto the boundary where phenomenon gets reversed due to axiomatic conditions.

Shown in Fig:17, the Linga Bhava transition mode, at the Abhimaan interface, forms a potential well, through conversion of the coherent symmetric state into a synchronous resonant state, at the same potential, across this gap. It is a linking, coupling or connecting region that changes simultaneous interactions to sequential interaction and viceversa without loss of counts. Potential Linga state changes to a Kinetic Bhava state across an axiomatic gap. The nodes in the simultaneous domain have a ratio shown in the derivation of  $Kx$  in EP13. In the Abhimaan region, there are synchronous, sequential and resonant states that are shown in Fig:17 as  $(k-1)$ , 7 and FM4 as  $\pi / 10$ . The change is the angular  $\pi / 10$  and  $(8-1)$  factors respectively. There are no changes manifested at this interface. As an  
208



## Secret Of Sankhya: Acme Of Scientific Unification.

example water forms into ice at the same temperature without loss of sensible heat yet ice has 'lost' latent heat. [This is the vanishing count event due to synchronisation of interactions.] In Fig:18 the outer lip at the circumference depicts sequential events that do not take place simultaneously. Hence interactive events would seem to rotate or spin or change position in sequential steps. The central hole depicts the simultaneous activity superposed or synchronised or phased in lock-step at the same radial location. It is the Andhathamishra or blackhole region. The dip or well formed can be understood by visualising the actions in this region.

Consider that the central section, for example, has 100 counts but grouped together in tens and distributed radially in 10 sectors around the 'hole' region. Opening out ten counts in an equalised mode would require 10 times the distance. But here the combined, interactive ratio  $7/(k-1)$  forms a constraint which results in a deformation due to a non linear rate of interaction of the Vikrithi or non-harmonious oscillations type. The Prakrithi mode at the mouth of the hole is separated by an axiomatic ratio of  $(k-1)$  from the next Prakrithi harmonic stata at the outer lip of the well. In between, the non-synchronous Vikrithi state displays a

lower potential or count rate and interactive states from both sides of the well attain a balance at the trough. The well indicates a lower potential or Abhimaan state with a lower count rate per cycle due to synchrony. As a result the absorption factor explained earlier comes into play and forms a stable and resonant state at the bottom of the trough. The ratio is exactly the count difference between Prakrithi state of PM or nucleon and the Vikrithi state of a lepton or Electron as 1837.42 This value is an axiomatic numerical ratio and this cyclic proportionality exists at the Linga-Bhava interface. The Prakrithi state gravitating from  
209

Secret Of Sankhya: Acme Of Scientific Unification.

the central hole region down into well meets the Vikrithi state too

Equation. S 3. E.

$PM \cdot \left[ \left( \frac{k-1}{7} \right)^2 \right] = 2.30862 \cdot 10^{-30} \quad Me = 9.110234 \cdot 10^{-31}$
$Me \cdot \left( \frac{1}{2^n \cdot A_n \cdot 2} \right)^2 = 2.30862 \cdot 10^{-30} \quad Ne = 9.528734 \cdot 10^{-35}$
$FM16 \left[ \left( \frac{7}{k-1} \right)^3 \right] \cdot \left[ \frac{7}{(2^n \cdot A_n \cdot 2)} \right]^2 = 2.30862 \cdot 10^{-30}$

Gravitating down from the outer lip to attain a balance.

The Prakrithi or hadronic state loses its denser superpositioned count to progressively take a curved path while the Vikrithi state loses its rate of displacement to eventually attain a superposed coherent or synchronous or superposed potential state. The balance is shown in FM16 exactly at 2.3e-30 fraction of a cyclic count. It is worth noting the subtle mechanism of control in maintaining the balance. The PM (Neutron/Proton etc) side has a fixed ratio of 7/(k-1) whereas the vector A<sub>n</sub> is a variable that matches the standing wave harmonic of 2<sup>n</sup> to maintain this balance on the Electron to Neutrino section over the outer rim. The Electron Me and Neutrino Ne are separated by the resonant potential difference caused by the nodal separation. While the Electron at the first Abhimaan potential-well balanced the Proton- Neutron configuration, the 7 Neutrino spectrum shown in the Raja Bhoothani region balanced the green Ahankar transition zone. Beyond it in the purple Sathwa state, the well known hydrogen spectrum, where the radiant zone commenced. Fig.19.

210

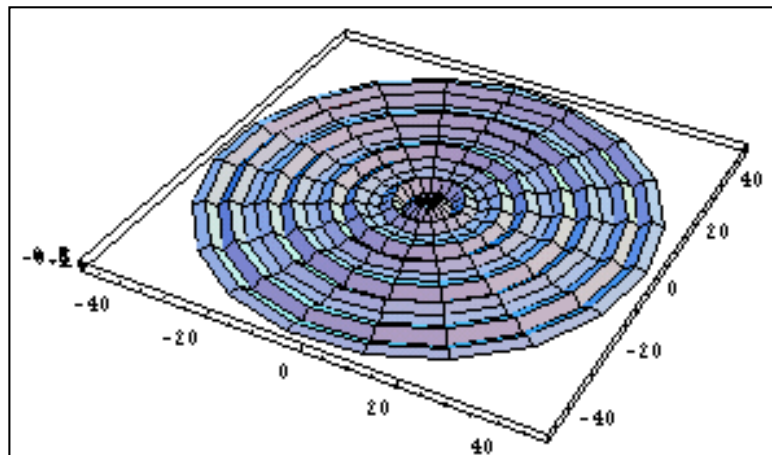

Fig: The Ahankar Spectrum Of 7 Ne States.

A notable point at this exotic interface of the Ahankar region, is that the potential changes by breaking resonance between the two axis in the Raja resonant region across a  $k-1$  gap to radiate Vrithis or Photons. The proof is in the mass-energy value of the 7<sup>th</sup> neutrino of 53.2 electron volts (EV) to the 13.6 EV of the hydrogen radiant spectrum. By placing Fig. 18 as the enlarged region in the central zone of Fig 19 the plancks constant with a potential value of 7 Ne or 372 EV resides in the hole while the Ne of 53.2 EV stays at the bottom of the well and the Hydrogen spectrum of 13.6 EV radiates from the outer lip through 7 nodal levels shown in Fig. 19. The mechanism of spontaneous creation of various particle states depending on density of interactive stable counts is in each region and is shown in the axiomatic derivations. Hence Neutron and Proton states are just the interactive counts at the top or bottom of the inner side of the well and the leptonic Electron or Neutrino states are similar bottom or top positions on the outer rim of the well. Similarly plancks constant of 7 Ne and Ne are the top and bottom states of the inner side of the well while the Vrithi or photon of Ne ( $k-1$ ) value radiate from the outer rim.

All these particulate states are created by hidden potential interaction that releases no evidence of its action. Because superpositioning or phase locking or simultaneous interactions are carried out within a cycle of 10 counts, which forms a 'logarithmical instant'. Hence only the log  
211

Secret Of Sankhya: Acme Of Scientific Unification.

index of cyclic changes of ten counts/cycle alter the values. In between, only the phase or angular relationships change without creating any detectable displacement. The hidden potential change is a magnificent simultaneous operation created only by the axiomatic conditions of all related parameters.. The mechanism of interactive change is given in the section 'Power House Of The Universe'.

Another proof for a cycle of 10 interactive events is shown again as it is relevant to the concepts in this Suthra.

Equation. S.3.F.

1	3	5	7	9	=25
9	7	5	3	1	=25
10	10	10	10	10	=50

Even numbered interactions or oscillations will be absorbed as a synchronised harmonic to form a standing wave or a nodal position. The odd numbered oscillatory rates will however tend to build up harmonics. Therefore the total number of incremental states possible are the five variations in the Guna spectrum and that leads to a total of 25 variations in both phases. That creates a standard cyclic variation of 10 counts at each stage that evens out to maintain an apparent static state. A standing wave does not consume energy and this sequence confirms that fact.

In later Suthras the cycle is derived and shown to be  $10 \left( \frac{n \times (n+1)}{2} \right)$  when  $n=4$  ) and the logarithmic value to the base 10 is the measurable value of C ;  $C = 10^C = 296575966$  oscillations per cycle. This is the stable oscillatory rate per cycle when there is no acceleration or rate of change of cycles. The numerical value is equal to the velocity of light in m/sec in physics. But in Sankhya it is the stable oscillatory ground state. The moolaprakrithi value is derived from it.

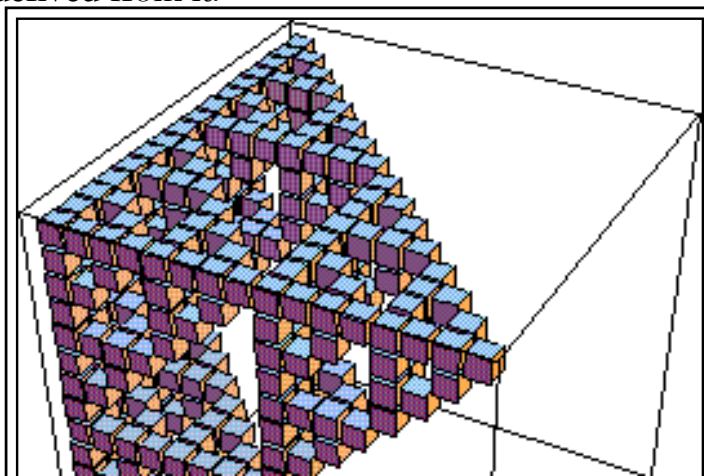

Fig: Observable Phenomenon.

In order to understand why space seems undetectable, a cubic section is shown with a 'random' aggregation of Moolaprakrithi states as coloured cubes. The cubes that are able to vibrate or oscillate due to non coherent interaction are shown with spaces surrounding them. The changing boundaries enable detection but in the rest of the apparently blank space the changes are undetectable and the cubes become invisible. The visible ones are in a vibratory state, hence become observable as matter or phenomenon. The blank sections are also field by the same elemental components but cannot be detected for they are in a coherent vibratory state. Suthra 32, defines the maximum acceleration or the minimum cyclic interval that makes it impossible to discriminate between two interactions. The field of action becomes continuous. While the interactive cyclic rate is  $C$  the limiting rate is  $C^{1+x}$ . That rate marks the boundary of two adjacent components and the extremely small interval hides the separated state of the components.

Secret Of Sankhya: Acme Of Scientific Unification.

Secret Of Sankhya: Acme Of Scientific Unification.

#### Suthra 4.

Verification of reality through axiomatic proof.

*drishtamanumaanamaapthavachanam*

perception-inference-axiomatic principles

*cha sarvapramaanisidhathvath.*

and complete-logic- by siddhi

*thrividham pramaanamishtam*

threefold rationale-appropriate

*prameyaasiddhi: pramaanaaddhi .*

theoretical- siddhi. logical theoretical container

**Meaning:** Siddhi or conclusive holistic proof is arrived at by a process of logical and theoretical analysis of information from observations, inferences and axiomatic principles. When such holistic conclusions are further condensed by using the threefold analytical process with appropriate rationale and theory, it is established as a conclusive axiomatic theorem.

**Explanation:** (Siddhi is also translated as a perfection meaning 'flawless.' Any proof of any theorem or proposition must be flawless or form axiomatic principles) The threefold analytical process is : Sequentially analysing information. Analysing the sequential information in permutation and combinations of the previous results and drawing inferential conclusions . Putting all the previous outputs together in a simultaneous mode and intellectually experiencing the foregoing results and deriving a set or unified unit of logic that can be used as the container or nested nugget for including more complex and related conclusions. It becomes a logical theorem

The process is the same interactive method followed by the Guna interactions, explained in later Suthras 11 to 18

## Secret Of Sankhya: Acme Of Scientific Unification.

The outcome of such a process is an acceptable, perfected, holistic, logical set of conclusions that can be called a theorem or principle.

The same process can be repeated with more complex input information to establish new principles containing within it earlier principles to form a nested holistically logical theorem or principle. The meditative process dealt with in appendix C covers the above principle in detail and establishes the unambiguous technique of attaining the skill of thinking or rationalising perfectly by following the same interactive process followed in the substratum.



Secret Of Sankhya: Acme Of Scientific Unification.



**Suthra 5.**

Process of verification of detectable phenomenon.

*prathivishayaadhyavasayo*

reference –sensory-persistent

*drishtam trividhamanumaanamaakyaatham .*

perception threefold -inferential-defininition

*thalingaalingapurvakamaapthashruthir-*

detectable-undetectable-source-axiomatic

*aapthavachananthu.*

axiomatic principle/theory

**Meaning:** With reference to persistent continuous sensory perception of phenomenon there are three aspects of factual information with characteristics like (positive) detectable , (negative) undetectable, (neutral) original characteristics that can be measured, analysed and interpreted to establish an axiomatic theorem or principle.

**Explanation:** In dealing with vibratory or oscillatory phenomenon, measurements or detection processes must take into account the three phases of an oscillation. Any oscillation adds parameters to an original or base level and goes below or displays a negative characteristic that must be inferred and obtaining factual data depends on this principle of analysing all the three phases.

Manifested phenomenon can be dealt with by using observational techniques in a referential way to establish empirical principles, rules and theorems. The neutral characteristics are the common or standard yardsticks established by common consent, usage, practice etc. As the absolute value of any phenomenon can never be measured or detected by the observer, as shown earlier, the positive and negative values are the incremental and decremental values the observer detects or measures with reference to a standard or neutral base value of his own choice, need

Secret Of Sankhya: Acme Of Scientific Unification.

or capability. The real meaning of a totally relative perception or detection or consciousness or awareness is established by this Suthra.

**Suthra 6.**

Process of holistic derivation of proof is siddhi.

***saamaanyathasthudrishtadathindriyaanam***

synchronised-moving expansive phenomena-imperceptible

***prasidhiranumaanaath .***

successful inference

***thasmaadaapichaasiddham***

hence-and also-holistic axiomatic proof

***parokshamaaptaagamaath siddham .***

experience mentally-axiomatic-deductive-holistic-proof

**Meaning:** And in the case of phenomenon that is imperceptible, mobile, expansive and hence undetectable, inferential method using holistic, deductive, logical, verification technique to mentally experience phenomenon, is known as siddhi.

**Explanation:** And in the case of phenomenon that is undetectable because it is synchronised, mobile, expansive or imperceptible ,inferential methods using holistic deductive logic (siddhi) is the only verification technique that will provide the proof.

From the very first suthra it was established by a string of rigorous logic that the fundamental substratum could never be measured, detected or dealt with through direct sensory interactive techniques of any type. Now this Suthra establishes that the verification of the basic substratum can be carried out only by rigorous logic through a structured system or technique called siddhi or holistic meditative system. It is a process of analysing information in a synchronous or simultaneous or parallel mode. This method can therefore be applied to any verification process where direct evidence or information is not available. In fact it is the system of perfecting the

221

## Secret Of Sankhya: Acme Of Scientific Unification.

rational & logical thinking process. Since the phenomenon is not detectable, a technique of providing an abstract basis is siddhi and the meditative procedures (appendix c) give an error proof answer. Science depends on mathematics to provide the rigour to verify the correctness of a theorem or a proposition.

But Sankhya lays emphasis on a specialised process of thinking that is superior even to mathematical logic. There are two important reasons both of which are dealt with in Suthras 2 & 14. The major reason is that even detectable phenomenon are experienced in the mind as a mental event before one gains total understanding of it. The process of mentally experiencing a phenomenon is in no way different from the laws governing an external event. The substratum of the mind behaves exactly in the same way as the universal substratum. The process of gaining perfect understanding is like the operation in photographic reproduction in a movie camera; the dynamic external scale of events are compressed or focussed to an internal scale and recorded perfectly every instant. The mind is capable of dealing with phenomenon in a similar way, not only with detectable but also abstract or synthesized inputs with perfection. It is said that a picture is worth a thousand words and it could be extended in a similar way to mean that an "instant" of a movie is worth a thousand "still" pictures but all these are only in the "visual field". By the same logic Sankhya siddhi process is a dynamic experience worth a thousand movies!. The verbal description of such an experience will be a complex process.

**Suthra 7.**

The reasons why manifestation may not be detected

***athiduurath samiipyadh- indhriyaghaathan***

too- faraway too close- sensory obstruction

***manon-avasthanat.***

mental - stresses

***saukshmyad-vyavadhanad- abhibhavat***

subtleties- occultation- predominance

***samanabhihara-cha .***

camouflaging -etc.

**Meaning:** Extremely far or near distances, mental and sensory inefficiencies, subtle or attenuated conditions, occultation or eclipsing of the object, poor background contrast, camouflaging effect (are the causes of non detection or non measurement of phenomenon).

**Explanation.** The individually obvious factors are listed below but there is a major collective reason that affects the detection process seriously. Items 3, 5, 6, 7 and 8 existing simultaneously can distort the result. However the same type of distortion occurs when vibrations or oscillations synchronise. If ten people clap their hands sequentially the ten claps can be detected as such. If they all clap simultaneously or at the same time then only one clap would be heard due to factors covered by items 3, ( poor discriminatability of claps), 6 ( one clap covers many claps), and 8, (one clap is heard but nine claps are hidden in the duration of the first clap) but it would be louder

## Secret Of Sankhya: Acme Of Scientific Unification.

than the single clap or its energy / potential value would be greater. Hence one must take all these factors into account consciously before coming to conclusion.

The factors causing the attenuation are self explanatory and needs little explanation to understand. A signal is really a variation in a background state of continuous dynamic change. The ability to detect implies that the observer has the power to discriminate these variations to get the real meaning to decode it effectively. Any obstruction obviously would interfere directly. But if the signal cannot be distinguished from the background dynamic state, the signal cannot be dealt with meaningfully. One cannot detect a candle at a distance in bright sunlight, or a particular sound in a cacophony of sounds, a particular coloured object against the same background colour etc. The explanation is as follows:

1. Athi-durath : too far = loss of signal strength due to great distance
2. Samipyad : too near = signal strength strong, overlaps, discrimination not possible
3. Indriyaghata: sensory obstruction = high resistance to signal transmission.
4. Manon avasthanat: mental or instrumental stresses and distortions
5. Saukshmyad: subtle or attenuated, low intensity
6. Vyavadhanad : occultation or eclipsing. = periodic physical obstruction in the signal path.
7. Abhibhavat : background contrast. = signal to carrier differential amplitude too small.
8. Samanabhihara : camouflaging effect, simultaneous events, signal noise at same level.



Secret Of Sankhya: Acme Of Scientific Unification.



**Suthra 8.**

The reason why the fundamental substratum is not detectable.

*saukshmyathadanupalabdhirn'abhavat*

subtleness hence non detection notnon-existence

*karyatastadupalabdhi .*

reaction therefore detection

*mahadadi thach cha karyam.*

intense-original following- actions

*prakritivirupam swarupam cha .*

oscillations- harmonics - fundamental

**Meaning:** The non detectability (of the substratum) is due to the extremely attenuated reactions put out and not because it (substratum) do not exist. Only reactions are detectable. For when the reaction of the primary or first displacement takes place then a sequence of oscillations are detected that are either in its original form or harmonics .

**Explanation:** The state of the components of the substratum are in a dynamic state but when the reactions from the interactions are very fine or subtle it may not be possible to detect it but that does not mean that there is no activity in the substratum of space. When there is an activity at source an intense reaction follows with a number oscillations that are in the original form or are distorted and therefore make it detectable in some aspect or another. When the coherent or balanced state is upset the non synchronous vibrations or oscillations become detectable.

As will be shown later, the substratum is in a dynamic oscillatory state due to the quality of self similarity , wherein due to gradient 1: 2 or rate difference of one unit, the internal state of the components is kept in perpetual

## Secret Of Sankhya: Acme Of Scientific Unification.

oscillation due to a third order damping force generated internal due to the rate of acceleration exceeding the cube of velocity during the change in parameters. The oscillations or permanent only because no energy or force is either radiated or absorbed in this process but is continuously balanced as an internal cycle. Only the unbalanced, secondary or reactive radiation is detectable.

**Suthra 9.**

Logical reasons why the substratum must exist if manifestation exists.

***asadhakaranadhupadhanagrahanath***

illogical-action-continuous-material cause

***sarvasambhavabhavath.***

acceptance all- possibility

***shaktasya shakyakaranath***

non existing ability-possible-act

***karanabhav cha***

cause-existence therefore

***satkaryam .***

law or axiom or rule

**Meaning:** It is a logical error to accept that continuous or all possible modes of action (manifestation) are possible without a physical cause; the ability to act in all possible ways must be due to the existence of a cause, therefore it becomes an axiomatic rule

**Explanation:** Logically only changes can be detected and a change is an action or activity. Activity cannot exist without a base or something to act on. Again reactions are result of an action so there must be a cause or an original reason. From the Suthra x it was established that only reactions are detected . There fore if something is detected there can be no effect without a cause nor can there be a reaction without an action. Detection of any manifestation must be due to an action , (the oscillatory nature of phenomenon) as outlined in the earlier Suthras . Action causes reaction and is equal and opposite. This Suthra lays out the foundation in a negative way to oscillatory dynamics. 1. Cause precedes effect and effect becomes cause for the next cycle, and will continue endlessly, decay

229

## Secret Of Sankhya: Acme Of Scientific Unification.

(stop) or resonate(increase) according to the timing or phasing explained below. 2. If within the duration of cause the effect is reversed (by any means) then the cycle is discontinued ( decay till cycle is stopped). 3. If the reversal of effect (by any means) is timed or synchronised with the termination of the causal cycle the static state is reached. 4. If the reversal of effect is timed or synchronised with the start of a cycle then the increase will sustain and grow to a state of self sustained resonance and if this timing is lost the cycle will decay.

**Suthra 10.**

Detection of manifestation is due to changes, the lack of which makes phenomenon undetectable.

*hethumathanithyamavyapi*

effect-temporary-non-pervasive

*sakriyamanekamashritham*

active-many-supportive

*lingam .*

potential characteristics

*saavayavam paratantram ayaktham*

with- mass dependant manifestation

*viparithamavyaktham .*

reverse- unmanifest-phenomenon

**Meaning:** The caused detectable effect of manifested phenomenon are relatively temporary; confined to limited region; proceed from action to action; resulting in a sequence of actions; and also becomes the cause of initiating further action; with identified characteristics; has the quality of being substantial or with mass; as it is a resultant, so it is a secondary trait; and the unmanifest cannot be detected because of the inability to discern such effects.

**Explanation:** This theorem must be understood very well to know the process of manifestation because it leads to an extraordinary conclusion. That is the observer cannot detect the permanent aspects of nature. Monotonous oscillations cannot be detected meaningfully.(the carrier wave lacks information.) Change is the cause of detection. Even if a dynamic event repeats the same set of details in a synchronised way such that no change is caused then the phenomenon is undetectable. The process of detection or measurement is a referential or a relative process and unless the phenomenon being measured has a comparable

231

## Secret Of Sankhya: Acme Of Scientific Unification.

foundation ,it cannot be detected. Comparison of both the static and dynamic qualities are necessary to understand it. Hence every aspect of an investigation must show this relative characteristic; like if time is measured then the phenomenon must be of a temporary nature or else it becomes the background phenomenon or the permanent state. Taking the locality of the phenomenon it must be confined to a limited region for it to be called an event ,else it becomes the background state; a permanent blue sky is the background to detect changes which show up as clouds, sun, stars etc. For the same reason only reactions can be detected since it is related to an action that is caused. If the cause is sustained then the reactions sustain a sequence of events or characteristics without which it becomes undetectable. The change that creates a phenomenon from a fundamental background state always produce a time (or duration) change indicating inertia or mass. Since any manifested phenomenon is the result of an initiated change then it can be considered only as a secondary activity hence the primary cause cannot itself be detected. Therefore the fundamental, originating causes can never be detected by any means by an observer who is a phenomenon himself, in the sense that his existence itself, is due to a reaction or secondary effect.



**Suthra 11.**

Characteristics of the three states of phenomenal interaction.

*thrigunamaviveki vishaya:*

triple-vectors-undetectable phenomenon;

*samanyamachethanam prasavadharmi .*

synchronised-inanimate generation law

*vyaktham thatha pradhanam*

manifest onwards primary force and

*thadviparithasthatha cha puman.*

Reverse-likewise and nucleus

**Meaning:** The inability to discriminate between the triad of stressed states that form the dynamic connection is the cause of not detecting phenomenon in a synchronised, static or unmanifest state. The triplicity of dynamic forces that connect it, is a principle that applies to the first or primary intense state and the succeeding reactive states of manifestation and likewise to the nucleus which however is in the opposite state (non detectable state).

**Explanation:** Please see explanation section on stress in Suthra 1, for a detailed explanation of the concept of Guna. The triad of stresses identified initially as internal, external and locally created are all connected by a single factor which is a force or a displacement acting in three modes called Triguna or triple activity vectors. If this triad of forces in any form is not detected then manifestation is not evident and dynamic phenomenon seems static and static phenomenon is undetectable. Hence it is termed a law or rule that if the Triguna is not detected than phenomenon seems unmanifest. In fact the non detectability of the nucleus or Purusha is due to the inability of the observer to detect the Triuna for the nucleus. It is called a nucleus because the activity of oscillations or vibrations

Secret Of Sankhya: Acme Of Scientific Unification.

that must be occurring in a dynamic substratum, cannot be detected by the observer in any discrete or measurable way but is only aware of its effects. Similarly radiation is detected only in certain groups that is called a spectrum while the universe is filled with a continuous sequence of wavelengths or frequencies. Therefore the observer must attempt to discriminate the triad of forces to detect and suppress it to not detect, and understand that non detection of phenomenon does not mean non existence of phenomenon but the triad of forces is not detectable for various reasons **Mathematical:** Time is accounted in terms of interactions. The even numbered interactions are divisible as powers of 2 and remain in the same location as nodes but odd numbered interactions spread as harmonics.

Unit time	$1^2 = 1$	$1 \times 1 = 1$	$1 + 1 = 2$	$1 - 1 = 0$
Time <sup>2</sup>	$2^2 = 4$	$2 \times 2 = 4$ $1 \times 4 = 4$	$2 + 2 = 4$ $1 + 3 = 4$	$2 - 2 = 0$ $1 - 3 = -2$
Time <sup>3</sup>	$2^3 = 8$	$4 \times 2 = 8$ $1 \times 8 = 8$	$4 + 4 = 8$ $3 + 5 = 8$ $2 + 6 = 8$ $1 + 7 = 8$	$4 - 4 = 0$ $3 - 5 = -2$ $2 - 6 = -4$ $1 - 7 = -6$
Time <sup>4</sup>	$2^4 = 16$	$8 \times 2 = 16$ $4 \times 4 = 16$ $1 \times 16 = 16$	$8 + 8 = 16$ $7 + 9 = 16$ $6 + 10 = 16$ $5 + 11 = 16$ $4 + 12 = 16$ $3 + 13 = 16$ $2 + 14 = 16$ $1 + 15 = 16$	$8 - 8 = 0$ $7 - 9 = -2$ $6 - 10 = -4$ $5 - 11 = -6$ $4 - 12 = -8$ $3 - 13 = -10$ $2 - 14 = -12$ $1 - 15 = -14$

Simplifying by removing even nodes the sum of the odd interactions in one direction add to 25 and in reverse, total 50. But in each location the total of 10 counts establish the cycle.

1	3	5	7	9	=25
9	7	5	3	1	=25
10	10	10	10	10	=50

Secret Of Sankhya: Acme Of Scientific Unification.



**Suthra 12.**

The qualities of the triad of forces that form the connection .

***pretharpethy Vishadhathmakah:***

buoyant-balanced-despair- self

***prakashapravritthiniyumarth: .***

expansion-interface-contraction-interaction

***anyo'anyaabhibhavaashrayajananamithuna***

mutually-domineering-interactive-creative-associative

***vrithyshravaguna .***

self-resonant-vectorial-quanta.

**Meaning:** Just as the human being undergoes, when under stress, a three stage transfer from a state of buoyant feelings through a calm state to state of utter despair; the three interactions of the guna are from a state of free and mobile expansion through a balanced and resonant interface to a state of compact coherent contraction. As a result the three states are capable of mutually interacting to override or strengthen or weaken ,one or both at the expense of the remaining aspects; be creative or destructive as a whole; associate or join or pair or combine to form groups; and also exist by itself as self supporting resonant or dynamic entity.

**Explanation:** Here the description of the triad of forces is given in holistic logic so that the student can experience the dynamic interaction in his own mind through the meditative process set out as a principle in Suthras, 4, 5 and 6. From our current scientific standpoint this Suthra is extremely important and informative. To understand it, some of the information from the later Suthras will have to be brought in at this point. Lets take the substratum containing the equalised components in a dynamic state and assume all of these to be vibrating or oscillating at a

## Secret Of Sankhya: Acme Of Scientific Unification.

rate of 2 oscillations per unit time with a displacement of 2 linear units in the same period and that all of them act in a synchronised manner and as a consequence all of the components subtend the same proportionate measurements relative to each other at any point in time and the change in direction happens at the same time in all the components when one component impacts each other . In this mental picture let us change by reducing the rate of the component to the left of the centred one, by 1 unit to one oscillation per unit time keeping all other parameters the same. A sequence of changing events will take place in a certain period till a balance is achieved with the altered situation. The unit at the centre in its excursion to the left will not impact that unit at the same time as the rest but will continue its excursion till it impacts at a later time, thereby causing a loss of synchronisation. The central component would have moved  $2 + .66 = 2.66$  units the left  $2 - .66 = 1.33$  unit in the same time of 2.66 units. Applying the same logic all the components around the left one would travel 2.66 units before impact because the left one would travel only 1.33 units.

In this example we see the action of the three guna - a delay reduces the distance allround thereby producing the effect of compaction or increase in density or mass and on the other side an extension of the distance between the impact points or an expansion of the space all round reducing density similarly and in between a balanced state or the interface where the changes oppose each other. Looking at this exercise holistically, we have taken a parameter from one zone to another thereby creating stress or an exchange of one characteristic that produces another type of change which is only possible in a dynamic state. It is the originating or normal state in Sankhya. The change from a synchronised or balanced state produces a stress or force or motivation or potential which if left to

238

Secret Of Sankhya: Acme Of Scientific Unification.

itself will return back to the original synchronised state in a sequence of changing events. more





**Suthra 13.**

Identification and defining of the three forces.

***satvam laghu***

radiant swift

***prakashakamishtamupaashtaambakam***

intensely-energetic-as-required-beyond-eight-fluidic

***chalam cha rajah: ,***

shuttling between is the resonant state

***guru varnakameva thamah:***

heavy as-if-bound coherent state

***pradipavacharthatho vrithi: .***

radiating-from-it- potential vortex

**Meaning:** Sathwa is the force which operates outward at the maximum speed with the required intensity and energy to transmit the force beyond the level of the first octet of forces past the nuclear boundary that is in a fluidic or flexible state. raja is the force in the transition region of seven oscillatory plus the first in the octet of forces; that shuttles inward or outward to transfer the forces from nuclear boundary to the fluidic boundary radial boundary and vice-versa; Thaama is the decelerating force acting inward forming the static nuclear boundary; vrithi is the resultant force that is radiated in the form of a selfsustained vortex (particle) created by the permutations and combinations of the previous three levels of forces to transfer force or energy.

**Explanation:** It has been already explained earlier that two unit volume oscillate at half the time period of a unit volume within a standard environment. Similarly a length of two units will have half the time period of a unit length etc. In this background the following is to be understood. The identification of sathva as the electromagnetic radiating force ; raja as the electro-weak bonding force and

241

## Secret Of Sankhya: Acme Of Scientific Unification.

thaama as the strong nuclear force complements the concept of the triad of forces or GUNA, as the different phases of a standardised waveform of an oscillating volume in the substratum . Vrithi is the mediating force transferred through a volume that attains a self sustaining particulate or inertia producing status when accelerated beyond a thresh-hold. The concentration of forces at a colliding point forming the crest of a holistic 3 dimensional or volumetric wave in the nuclear region with the qualities of inertia or mass being displayed in each cycle along with the associated quality of thaama or strong force. At the trough of such a wave the equalising quality of sathwa or the orbital balancing electromagnetic force exists in each cycle . Both thaama and sathwa have the quality of time permanence in each cycle as these form the turning points or nodes of the cycle. In the intermediate region however there is a continually changing force that is either accelerative or decelerative in each half of the cycle and it gives the quality of a changing or shuttling force which is Raja or the weak charge changing force that bridges the electromagnetic and strong force regions in particle physics.

Secret Of Sankhya: Acme Of Scientific Unification.



Secret Of Sankhya: Acme Of Scientific Unification.

**Suthra 14.**

Holistic logic can identify both manifest and unmanifest nature.

***avivekyadhi :***

non detection;

***siddhahtraigunyathadhviparyayabhavath .***

axiomatic-triad of forces such reverse non existing

***karanaathmakagunahtvath***

motive-self-by-the-trad-of-forces

***karyasyavyaktamapisiddham .***

effect-unmanifest-also-axiomatic-analytical-process.

**Meaning:** Through a process of holistic analytical derivation of proof it is proved that non detection or detection is due to the observers inability or ability respectively to detect any or all of the three modes of exchange or transfer of forces. And the very process of siddhi or 'holistic analytical derivation of proof' is itself due to the unmanifest state of the substratum reacting through the action of the gunas or three modes of transfer of forces by it's own inner motivation or potential or cause or interaction to manifest as awareness or consciousness

**Explanation:** The important point made here is that siddhi follows the same fundamental process nature uses in all its interactions. The process of detection of phenomenon or other wise is dependant on the observers ability to detect any or all of the three modes of transfer of forces, as it is proved by analytical holistic logic that every effect must have a cause or every reaction must be preceded by action and the detection of effect or reaction is connected with detecting any of three forces of the triad. Non detection of phenomenon does not mean a phenomenon does not exist. While hearing, seeing,  
245

## Secret Of Sankhya: Acme Of Scientific Unification.

smelling etc. allows the observer to witness certain forms of manifestation, other senses will expose different levels of phenomenon. The process of siddhi follows the fundamental interactive rules of the triad of forces ,so the logic of the results are the same. Therefore the corollary is that if by logic a particular state or mode of phenomenon is derived as a necessary state of existence then such a state must exist but the observer may not detect it for the reasons already enumerated above. The nature of transmission of force are such that manifested matter and phenomenon may not be detectable and hence can exist in forms and interaction that are opposite to our current experience such as antimatter, dark or invisible matter ,black holes and time reversed phenomenon. If holistic logic predicts a phenomenon, it must exist even though the senses may not detect it.

**Suthra 15.**

The result of a cyclic force is a natural waveform.

***bhedhanam parimanath***

changing value of measure

***samanvyathshakthitha: pravrittheswa .***

sequential power                      cyclic action

***karanakaryavibhagathavibhagadhvaisvarupasya .***

cause-effect-attenuation-concentration natural waveform

**Meaning:** Cyclic interaction at the interface is due to a sequentially changing value that is due to acceleration or deceleration of a force . This cyclic action is the cause and effect, by turns, to attenuate and concentrate (expand and contract or rarefy and pressurise or decrease and increase density) to produce a waveform that is of a standard form in nature.

**Explanation:** Here the characteristics of a dynamic substratum is being defined. The Gunas, as shown , are the three modes of variation of a force due to cyclic reversal in an oscillating volume and when it is applied on a continuous basis a standard form emerges that is universal. It is an oscillating volume with standard form , a spherical wave form. In Suthra 30 the time and cycle characteristics define the mathematical expression governing the interactive guna states.

The diagram ‘Transmigration of vibratory stresses’ shows the interactive nature of stresses and how it transmigrates across the substratum of space. Two spherical interactive forms remain in the same relative locations when stresses are equal all around it. On being triggered into an unbalanced state the vibratory stress forms transmigrate in a direction to equalise. But that process increases and decreases the vibratory counts by superposition and rarefaction so that density counts increase and decrease

## Secret Of Sankhya: Acme Of Scientific Unification.

cyclically. This Suthra defines that very clearly that the interactive process between components in the substratum creates varying stresses cyclically. In order to equalise, the uneven vibratory stresses in a confined medium, transmigrate periodically according to the Guna laws of self-similar proportionality. The transmigration of the composite Guna ensemble is diagrammatically shown in three sections. The top and bottom coherent states represent the undetectable aspect in non accelerated phase. The middle part shows the compressive / expansive transfers.

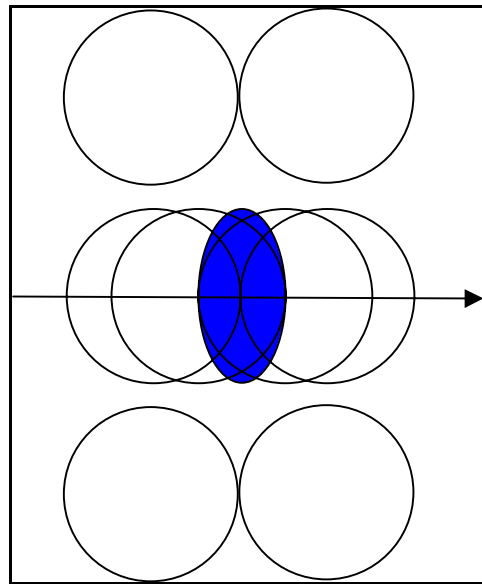

Fig: Transmigrating Vibratory Stresses

The rate of increase and decrease follow the Swabhava mode mode of simultaneous transfer within the cycle as  $c^{1+x}$  as the incremental rate and  $c^{1-x}$  as decreasing rate at the same time in different regions within the stress domains. Such a process is a natural way to create waveforms. Two major points are highlighted through this Suthra. One, no objects or substantial entities move physically and two, that detecting the repetitive stress



Secret Of Sankhya: Acme Of Scientific Unification.

forms in the same location gives rise to the idea of substantial process. If vibratory stresses oscillate in the same location it is seen as an objective particle. In case it transmigrates it gives the impression a dynamic waveform.

**Suthra 16.**

A first change of phase or fluidic state occurs with rising force.

***karanamasthyavyaktham pravarthathey trigunath:***  
cause-reducing-manifestation initiating triple-guna-action  
***samudayaccha .***

and decelerative action

***parinamath: salilavath***  
changing state like fluid

***prathiprathigunaashryavisheshath .***  
towards-very –estful-interaction-a-distinctive-phase

**Meaning:** In a manifestation of diminishing potential ,the triple interactive state initiates a restful state of coherence and synchronisation and a transformation occurs ; a distinctive change of state, like that of vapour condensing to liquid, takes place when the inward going force is brought to a very synchronised (=synchronised therefore static ) state .

**Explanation:** The reason why the unmanifest substratum becomes manifest is clearly explained using a principle that is very well understood today. During the oscillatory cycle if the decelerating force can be brought to a very restful state a change of phase occurs thereby increasing density or inertia or mass such that it becomes detectable or manifest due to the change. Taking water vapour as an example ,if the temperature which really is an indicator of the state of oscillation (or energy content) is brought down to state where the rate is lowered to the point of relative rest or zero temperature the vapour condenses into water which is now detectable as a different unit or element. In the next Suthra the same logic is continued to show that

250

Secret Of Sankhya: Acme Of Scientific Unification.

from the liquified state a condensed core state or solid phase change occurs.

Secret Of Sankhya: Acme Of Scientific Unification.

**Suthra 17.**

The second change of phase creates the solid or nuclear state.

***samghathaparaarthathvath***

collision-background-cause of

***thrigunaadhiviparyayadhadhishthaanaath .***

guna-interaction-start-reversal-of-starting location

***purusho'asthibhokthrabhavath***

nucleus-resting-absorbing-action

***kaivalyaarthapravritheshwa .***

unhindered-potential-of-cyclic-action

**Meaning:** The nucleus is the location, centre or core that holds the power, force or energy produced as a result of the cyclic collision or aggregation due to close contact, back to back, of the oscillating volumes or waveforms , initiated or triggered into action by the operating principle of the triad of forces, in a relatively isolated , static, unhindered state of freedom .

Explanation: Recalling that from Suthra 8 to 11 ,the inability of the observer to detect, measure or deal with the substratum in anyway was not possible due to the relative nature of detection itself ,but theoretically sets out a procedure to prove the existence of the substratum by logical inference. Here again, the nuclear or core region logically must be a part of the substratum , but not being detectable directly, this Suthra establishes the nature of this core as a pure potential or sole repository of the force or energy in a completely restful state but makes it clear that it seems restful only because it is the region of continuous collisions or close contacts with numerous waveforms, which are the only detectable forces by the observer. The Suthra has portrayed a picture of a number of volumetric waveforms in a dynamic oscillating state colliding cyclically

252

## Secret Of Sankhya: Acme Of Scientific Unification.

or periodically and the region where such action takes place is the holder or container of power in a static form and in a relatively restful state, due to the operating principle of the gunas; which means the core or nucleus is a holistic crest of a wave where the density is high hence has a mass only due to accumulation of all the oscillations in that region in a smaller region for a certain proportion of time. Nowhere in the Suthra is there a reference to the substratum or any matter of any form, to give the nucleus the quality of solidity massiveness and the like that normal common-sense attitudes require. At the observed level the confinement of water under pressure produces the isolation of the nucleus into regions of strong bonding or rigid states thus creating the solid phase while the individual regions are in state of attenuated oscillation.

**Summarising:** The Purusha or nucleus is the region in which a periodic collection of waveforms due to the mode of action of the gunas seem to be in a static state of dormant potential in the undetectable ,absolute subtratum that is omnipresent, omnipotent and omniscient and the period being determined solely by the time constant referred to in suthra 3 and forms the self potential refereed in suthra 2. b therefore from the above it can be concluded that the nucleus is a synthesised permanent region in the absolute sense and therefore it can never be detected in a direct or measurable way. there will always be a nucleus or Purusha.

Secret Of Sankhya: Acme Of Scientific Unification.

**Suthra 18.**

18. Logical proof that the nucleus is a conglomerate entity.

*jananamaranakaranaanam*

creation-decay-activity-consequence

*prathiniyamaadhayugapath pravrittheswa .*

general-rule-not-simultaneously cyclic-action

*Purushabahuthvam siddham*

nucleus-plurality logical proof

*thrignyaviparyayachaiva.*

Triad-of-forces-inversion-the only cause.

**Meaning:** Since the causative action leading to aggregation and dissolution or creation and destruction are not simultaneous or instantaneous at the nuclear interface. The axiomatic conclusion is that there must be many nuclei or individual core components (Purusha) and also because the reversal of interactions of the triad of forces (gunas) produce multiple types of phenomenon whereas it should have been singular, otherwise.

**Explanation:** The logic of this Suthra is extremely profound and establishes the error in the interpretation of other vedic works that have led to the identification of the Purusha as the soul of human beings specifically whereas the logically derived meaning shows very clearly that in any interaction if there is a delay in the cause-effect or action-reaction cycle it is only due to the effect of the nucleus or a self-supportive entity- the Purusha. (The concept of a distinctive human soul brought about the necessary reverential connection to the unitary SOUL that operated beyond the bounds of human logic.) The action reaction cycle being operated by a unitary principle of polarisation, as Gunas, would logically produce a unitary class of results if the nucleus were also classified as a unitary or solid type. But the observations show the

## Secret Of Sankhya: Acme Of Scientific Unification.

opposite and the nucleus being the provider of the static or passive background potential the conclusion logically must be that the nucleus as a class cannot be of a unitary type. To provide the basis for the many varieties of manifestations the nucleus must be classified as a pluralistic category. Hence the nucleus must contain many Purushas or many combinations of nuclei or elementary articles.



Secret Of Sankhya: Acme Of Scientific Unification.

**Suthra 19.**

The complex nuclear state forms the background for manifestation of phenomenon.

***thasmacchaviparyasath siddham***

from previous and conversely holistic proof

***sakshithvamasya purushasya .***

forming background state nuclear region

***kaivalyam madhyastam***

unhindered neutral state

***drishtarthvamakartrabhavashwacha .***

detectable-reference-ground-state

**Meaning:** From previous Suthras, the conversely inferential holistic conclusion is that the nuclear state forms the background state with particulate or inertial mass, in which it is relatively seen as being neutral, unhindered and neutral state to measure against..

**Explanation:** The Gunas or the triad of forces were identified with the wave forming characteristics ,wherein Thaama had qualities that were the opposite of the other two. Raja and Sathwa were relatively dynamic states. Raja formed the bridge or connection between outer and inner regions while the nucleus formed a central core drawing itself in to form a more dense and massive state. The Sathwa balanced the different forms actively across extended boundaries while becoming less dense. The core region with the opposite qualities became the necessary supportive framework for manifestation to occur like the inert, supportive canvas backing for a painting or the light reflecting screen for projecting a movie film. Without the core or nuclear structure manifestation or phenomenon could not have taken place meaningfully. Yet the nucleus or Purusha was not the fundamental substratum but was

257

Secret Of Sankhya: Acme Of Scientific Unification.

only a passive third partner in an interactive triad of forces  
all arising out of the substratum. more.

**Suthra 20.**

The state of sustained interaction is a state of balance

*thasmathath samyogadhachethanam*

therefore association-static-inert-state

*chethanavadhiva lingam .*

dynamic-as-if characterised

*gunakarthathey cha thattha*

action of gunas and thus

*kartheva bhavathithyudhasina: .*

dwindling-action-a-if existence-neutralised.

**Meaning:** Because of the proximity of the static and dynamic states, the static state seems dynamic, through the action of the gunas. The dynamic seems to behave in a neutral mode that maintains a balance.

**Explanation:** The relatively static nucleus and the dynamic surface( of the oscillating volume) attain a state of balance through the interaction of the triad of forces. Therefore relatively the impression is given that the static nucleus is dynamic and the dynamic surface is static while in the balanced state. Moreover , unlike the normal experience, a state of balance is a state of dynamic interaction to sustain a static or equalised displacement on a continuous basis. Therefore a state of balance is a dynamic interactive state wherein all the measurable parameters are the SAME and therefore seem STATIC . The active force or prakriti seems static and the static nuclear region seems active. There is synthesis of two different qualities into one unitary state and therefore could form or assume the fundamental status or role of ground state. more

**Suthra 21.**

Measurement or detection of phenomenon at the fundamental level.

*purushasya dharshanaartha kaivalyaartha*

nuclear state detection-potential unhindered- potential

*tatha pradhanasya .*

therefore fundamental manifested state .

*pangvadhavadhubhayorapi*

lame-blind –interdependance-similarly

*samyogasthath kritha: sargah: .*

combination thus proceeds manifestation

**Meaning:** Fundamental measurement of phenomenon references nuclear potential in an unhindered and synchronised state. Therefore the synchronised nuclear state provides the basic background to detect or measure the first, (primary or fundamental) active (manifested) state as a comparative or relative difference. Manifestation of phenomenon proceeds on the principle of fulfilling the need to maintain a balance like when a blind man and lame man team up to behave normally and effectively. From this combination all manifested proceeds.

**Explanation:** All phenomenon is a holographic presentation. It is the unsynchronised state of vibrations that is detected. But the substratum is not detected always. Yet it is in a dynamic vibratory state. Hence there must be a situation where it is active yet does not display or manifest. This theorem shows how it is always dynamic yet is in a free or unhindered or isolated state from the surrounding environment.

Suthra 21 sets out an actual example of the association of two men, one lame and the other blind to bring home the point of not only control, but also the factors of dynamic and static state in a synchronous mode, the  
260

## Secret Of Sankhya: Acme Of Scientific Unification.

interdependance of relative motion in an interaction, the nonexistence of time as an operating part of reality and the total freedom in the static state.

Here the principle of uncertainty is explained. Like the blind man has to await the visual instruction of the lame man, sitting on his shoulders, the lame man has to wait for the blind man to move before he can give a renewed set of instructions. If these reciprocal events of cause/effect or action/reaction take some time the observer has no way of finding out the intervening events. As an example, let us imagine the lame man gives instructions to the blind man to move a certain distance at a certain rate and direction and as he starts to take a step along a weak bridge, a section just in front falls off. Unless the lame man is able to assess this situation fast enough to give timely instruction to the blind person before his next step he will stumble into the gap. This example shows a number factors involved in control.

Seeing and moving are interactive and synonymous with detection and movement ; detection itself consists of a 'seeing' and 'informing' activity while movement has two phases of 'responding' and 'initiating'. In this sequence of four steps, three are internal and until the actual detectable movement starts, there is complete uncertainty of the state of this interval. In the next sequence the past action would be completed and if continued the overlapping nature may hide the actual discrete nature of activities required to keep the duo in motion.

That is why the prediction of events in the intervening period depends on the trends of the previous confirmed events and statistical methods have to be resorted to. Also the detection of the event is made possible only because there is a synchronised background of the nucleus; only against which the process of measurement or detection can be made meaningfully to initiate consequent action. Restating the above differently it becomes evident that the

## Secret Of Sankhya: Acme Of Scientific Unification.

fundamental substratum is not static yet it resembles a static state because of synchronisation, balance and coherence.

It is not detectable because there is no externally radiated information ( and what happens internally the observer has no way of confirming) and when it (substratum) polarises into the synchronised (and therefore a relatively static) potential and the unsynchronised kinetic dynamic phase due to a self-similar divisional mode, the first evidence of manifestation is available to the observer because the instantaneous action/reaction cycle now is delayed in attaining a balance, which then propogates a chain of interactive events in its effort to attain a balanced state or a state in which the nett action/ reaction energy or the nett time interval is zero at some level.

Most important: this suthra lays the foundation for the dynamic, selfsimilar and selfsufficient state that forms the relatively "static" background in a dynamic state. Against which detection of manifested phenomenon could be meaningfully interpreted and understood. The unhindered or free manifested state of the dynamic substratum must be due to an inherent quality that while making it the first or primary manifested state, it is still not detectable because it neither takes or gives out energy and therefore seems to be static and undetectable. The next suthra reveals this profound state in mathematical terms. It is the "ekanthathyanthathobhavath" of the very first suthra.

The reader should not the special effort taken to explain the nuclear state in 5 Suthras (17,18,19,20 & 21). It is to highlight the extraordinary nature of the nuclear phenomenon. Maharishi Kapila takes the nucleus as the central, fundamental, important and "background forming" phenomenon and makes it very clear that its characteristics are not a fundamental but a relative state due to the dynamic nature of the substratum and the

262

## Secret Of Sankhya: Acme Of Scientific Unification.

nucleus is also a manifested or a locally created phenomenon but with the opposite qualities in relation to the active prakrithi, which is also a manifested phenomenon. The substratum is the only absolute and permanent state and therefore undetectable and unmeasurable. To reiterate, in suthra 17, the solid nature is a state similar to condensation, where the displacement is below detectable limits ( and hence seems to be one solid unit). In suthra 18, holistic logic is used to dispel any lingering doubt that the nucleus is a singular, particulate, solid component because, only the components of the substratum could have this quality, but because of this very quality the substratum becomes undetectable. The nucleus is detectable as a result of the interaction with the active prakriti, but because such reactions are not always the same it must be concluded that the nucleus has different characteristics submerged in an apparently singular, "solid" state. Further a very important point is emphasised here - the nucleus is not the ultimate particle or entity or component of the substratum. In suthra 19, the apparently static, conglomerate nuclear body or entity forms the reference or background or zero potential state, only against which any measurement or detectable parameter can be meaningful, like a voltage has a zero reference point, or height of a building refers to ground level and so on. It is obvious that there is no other choice when the substratum is not detectable and the active prakriti is ever mobile, whereas the nucleus is relatively static and detectable by comparative methods. In Suthra 20, the starting point for detection or measurement is established by bringing about a synthesis between the static nucleus and dynamic prakriti when both seem to be the same or each one has the opposite qualities and this is when both are in a state of interactive balance. It is very evident that the two states are not unique elementary objects formed once and for all BUT actually two

## Secret Of Sankhya: Acme Of Scientific Unification.

complementary states that are formed and reformed interchangeably! In suthra 21, the highly complex phenomenon of the nuclear state is designated the role of the fundamental state from which and only from which the observer can detect and measure and understand phenomenon in a correct and meaningful way. Therefor the ground state is an apparently synthesised manifestation of static and dynamic states in interactive balance.

The reason for the existence of the principle of uncertainty in confirming the manifested parameters is given by fundamental logic. most importantly, it shows the need for the prime dynamic selfsufficient state to explain all phenomenon.

Summary note: the undetectable substratum comprising limitless, undefinable components in a dynamic synchronised state and therefore undetectable, polarises into static and dynamic states through nonsynchronisation caused by obstruction and becomes manifested or detectable or measurable and the value of the measurable parameter is related to the nuclear state when in a state of balance or synchronisation with the active dynamic polarised element. the above is very relevant to current concepts in physics. the nucleus is identified as a conglomerate structure and nested into various sub nuclear energy levels comprising the baryon spectrum of mesons, quarks, bosons etc, all of which are not normally detectable unless interacted in high energy accelerators. the atomic spectrum, being the stable manifested phenomenon, comprises the nucleus (Purusha) as the massive static hadronic component kept in balance or synchronous state (Thaamasic), by the dynamic, leptonic component (prakriti in the satvic state) through interactive mediation of the basic field made detectable by the electromagnetic oscillatory phenomenon of photons (vritti in the rajasic state), through emanations at the first level corresponding to the compton wavelength Thaamas  
264



## Secret Of Sankhya: Acme Of Scientific Unification.

are all purely relative to the Purusha and being the nuclear phenomenon, its absolute level depends entirely on the observers sensitivity to discriminate changes at the subtlest level. the same relative set repeats itself ad-nauseum as nested levels of manifestation; and as a result the same set of mathematical laws apply at all levels and the scale is time symmetric. holistically its like looking at a spaceship vanishing into the distance and while the image of the ship diminishes proportionately the observer can rest assured the same set of mathematical rules are in operation, in it, all the while and will always be so, even when the ship becomes a mere dot.

**Suthra 22.**

Mathematical derivation of the dynamic selfsimilar state.

***Prakrithermahamasthaatho'ahankar-***

oscillatory intense expanding moving continuously self acting

***asthasmaadhgannaschashodashaka: .***

expanding in this way calculated and sixteenth diffusing

***thasmadhapi shodashakaath panchabhya :***

in this way also sixteenth binds fifth power encircles

***panchabhoothani .***

the 5 levels of manifestation.

**Meaning:** By the action of the primary force a self sustaining oscillatory state is established from which a series of measurable or detectable signals are radiated at a value that is a sixteenth of the primary value and in a progressive series incremented to the sixteenth level that binds or condenses phenomenon through five levels into five sets of manifested phenomenon.

**Explanation:** This is the most important theorem in the science of unification of all phenomenon in the universe. As a first step the holistic equation set up in this Suthra in the latter part will be presented in a graphical way to make it understandable.

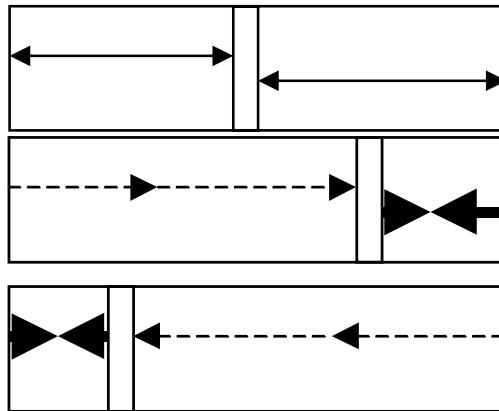

Secret Of Sankhya: Acme Of Scientific Unification.

Fig: Self-similar Interaction.

Self-similarity, acting instantly in a confined region, is controlled by a single ratio that operates in 3 Guna modes. The piston in the middle of the cylinder is retained in position by equal pressures on both sides. If the piston has to move then the pressure on one side has to increase while at the same moment the pressure must decrease in the same ratio within the same period on the other side. The two diagrams show the possible movements that can be defined by the same mathematical expression. The thin arrows show expansion and the thick ,compression. The important point to focus on is that both expansion and compression must take place at the same time or simultaneously. That expansion is an incremental function while compression is a decreasing function at the same instant of time and the relative proportion must also remain the same to produce that movement. Though the cylinder is a volumetric space the degree of movement can be expressed as a linear ratio as the areas on either side of the piston remain the same. If the amount of change from midposition is y then the equation can be represented by:  
Equation S 22.

$$\left(\frac{1}{2} + y\right) + \left(\frac{1}{2} - y\right) = 1 \quad \left[\left(\frac{1}{2} + y\right) - \left(\frac{1}{2} - y\right)\right] \cdot \frac{1}{2} = y$$

$$\frac{\frac{1}{2} + y}{\frac{1}{2} - y} - \frac{1}{\frac{1}{2} + y} = 0 \quad \left(\frac{1}{2} - y\right) - \left(\frac{1}{2} + y\right)^2 = 0$$

$$\frac{\left(\frac{1}{2} + y\right)^3}{2} = y$$

Secret Of Sankhya: Acme Of Scientific Unification.

The first row shows the sum and difference caused y. The second row shows the rate of change as a proportion that must be equal, at the same time. The third row shows a limiting condition for the value of y to be precisely evaluated. Though numerous equations emerge as a corollary with exceptional predictability, solving the above by the sum of squares gives :

Equation S.22 A. Derivation of self similar value is shown.

$$y := \frac{\sqrt{1+2^2}-2}{2} \quad y = 0.1180339887 \quad \frac{\left(\frac{1}{2}+y\right)^3}{2} = 0.1180339887$$

$$\frac{1}{2}+y = 0.6180339887 \quad \frac{1}{2}-y = 0.3819660113$$

$$\frac{\frac{1}{2}+y}{\frac{1}{2}-y} = 1.6180339887 \quad \frac{1}{\frac{1}{2}+y} = 1.6180339887$$

The solution shows the ratio equals the golden mean where x=0.618034. The process of binding or encircling is created if resonant oscillatory action is maintained at the ratio of x. Using the self similar ratio in an iterated mode creates the ratio  $\pi$ . The algorithm is shown below.

Equation. S 22. B. Derivation of the ratio of circumference to diameter is shown below.

$$j := 0..100 \quad A_0 := \frac{x}{2}$$

$$A_{j+1} := \frac{\sqrt{\left[1 - \sqrt{1 - (A_j)^2}\right]^2 + (A_j)^2}}{2}$$

Secret Of Sankhya: Acme Of Scientific Unification.

Equation S.22.C. The solution to any iterative level is shown.

$n := 1 \quad A_n \cdot 2^n = 0.3128689301$	$n := 5 \quad A_n \cdot 2^n = 0.3141542188$
$n := 10 \quad A_n \cdot 2^n = 0.3141592604$	$n := 100 \quad A_n \cdot 2^n = 0.3141592654$

Taking the limit of  $\frac{1}{2}^3 = 1/8$  then the sum  $= 1/16$ . Factoring 8 in a self similar way gives 5/8 and 3/8 approx. in the same proportion as  $x$  and  $x^2$ . Then  $16-3=13$  and  $8+5=13$  and  $8+3=11$  and  $16-5=11$ . These values become the power index in simultaneous interactions. The mechanism of how the Purusha and moolaprakrithi states maintain the oscillatory state perpetually is derived in later Sutras. But this Sutra lays the foundation for the manifestation process. The electromagnetic spectrum is formed by the polarisation process derived above as the electric field at the 11<sup>th</sup>. power index and the magnetic field at the 5<sup>th</sup>.

Explaining the process specifically, the Purusha forming the background or ground state, polarises the interactions along two axis into  $8+8=16$  orders. Then  $8+3=11=16-5$  orders form the expansive or accelerative states while  $8-3=5=16-11$  orders form the compressed or superposed and accelerative states. These indices are the electric and magnetic polarisation of the field and as the superpositioning densities increase the characteristics of manifestation changes into five levels.

. The sequential increment in rate of oscillation as logarithms to a cyclic (yuga) base of 10.

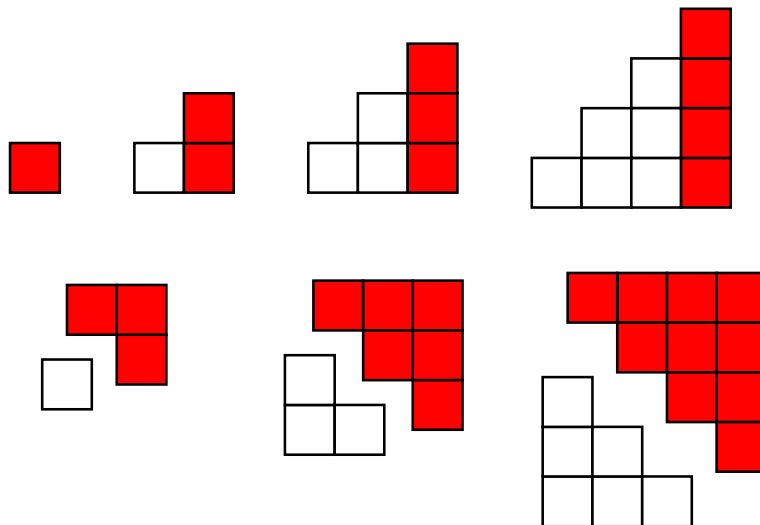

Secret Of Sankhya: Acme Of Scientific Unification.

Fig: Self-similar Resonant Combinations.

Sequence  $n+1 = 1 + 2 + 3 + 4$  phases in cycle = 10  
 Increment  $n \times (n + 1) \times 1/2 = 1 \quad 3 \quad 6 \quad 10$  value of  
 increment. Combining to get even index for divisibility  
 $(1 + 3 = 4 = 2+2) \quad (3 + 6 = 9 = 4.5+4.5) \quad (6 + 10 =$   
 $16 = 8+8)$

Equation. S.22.D. The spectrum of electromagnetic  
 phenomenon is shown below as two phases in the Raja as  
 5 orders and Sathwa as 11 orders of interactive counts per  
 cycle.

n := 0.. 5	
$\frac{(c^x)^3 \cdot \frac{KV}{Px} \cdot Kx}{10^n \cdot \sqrt{k}} \cdot 1$	$c^2 \cdot \frac{10^n \cdot \sqrt{k}}{(c^x)^3 \cdot \frac{KV}{Px} \cdot Kx}$
$1.131829479 \cdot 10^{16}$	7.7712505097
$1.131829479 \cdot 10^{15}$	77.7125050973
$1.131829479 \cdot 10^{14}$	777.1250509725
$1.131829479 \cdot 10^{13}$	$7.7712505097 \cdot 10^3$
$1.131829479 \cdot 10^{12}$	$7.7712505097 \cdot 10^4$
$1.131829479 \cdot 10^{11}$	$7.7712505097 \cdot 10^5$

Secret Of Sankhya: Acme Of Scientific Unification.

Secret Of Sankhya: Acme Of Scientific Unification.

**Suthra 23.**

Ascertainment by axiomatic mathematical logic.

***adhyavasayo buddhirdharmo jnanam***

ascertainment intellectual-axiomatic knowledge

***viraga aisvaryam.***

objectivity power level

***sathvikamethadhrupam***

expansive-is-this-mode

***thaamasamasmadviparyastam.***

Contractive-therefore-reverse

**Meaning:** Intellectual logical confirmation process involves the application of axiomatic law in an expansive mode, backed with knowledge, flexibility to change scales and ratios in the order of powers whereas the opposite contractive, inverted and fractionising concepts lead to misconceptions and errors of judgement.

**Explanation:** The form of logic that should be used for obtaining proof or verification is given as a holistic process using expansive mathematical logic in the order of powers or exponential ratios. In simple terms fractional or decimalisation techniques of mathematical logic would result in erroneous concepts and would not help in deriving the correct proof. As indicated in the beginning the logic was to breakdown manifestation to the lowest common factor and use it as the logical yardstick. Hence one becomes the logical choice for a numerical yardstick . Fractional numbers are open ended in the diminishing scale and therefore do not provide a natural limit as the number one. One is to be seen as the ratio of two or more equal components or numbers , like  $2/2$  or infinity/infinity are equal to one but normal mathematical logic implies that all numbers are indeed related to one; such as  $2/1$  or infinity/1 maintain the individual values.



Secret Of Sankhya: Acme Of Scientific Unification.

Therefore one is, repeat one is, the smallest number. Holistic logic then uses one as the smallest unit of measure. Any small fractional number can be converted by reciprocalisation into its unit relationship. The proportionality of numerical relationships can be maintained by the power or exponential relationship. Like 1.2599 cubed is 2 and 2 cubed is 8. Therefore using 2 as the equivalent of 1.2599 would yield the same ratio as 8 to 2, so a fraction of 1.2599 is avoided. What is the advantage? The most complex calculations can be accomplished mentally for one thing and incidentally one does not need logarithmic and trigonometric tables in mathematical calculations and the associated errors existing at the limit of its proportionality. The spectrum of vibrational combinations is shown using integers: A cycle has 10 levels and maximum of 50 on each side is reached at balance by combining odd and/or even states. It applies to the periodic and particle spectrum.

If odd numbers are added as  $1+3+5+7+9=25$  and repeat it as an ascending scale then  $1+3+5+7+9+9+7+5+3+1=50$ , gives the maximum spread of spectral scales without repeating.

1	3	5	7	9	=25
9	7	5	3	1	=25
10	10	10	10	10	=50
2	2	2	2	2	=10

Even numbers add up but the harmonics gets submerged in it

2	4	6	8	=20
8	6	4	2	=20
10	10	10	10	=40
2	2	2	2	=8

The coherent spectrum is contained in 8 and the radiant spectrum in 10.

Secret Of Sankhya: Acme Of Scientific Unification.

**Suthra 24.**

Mathematical description of internal field force as a spectrum.

***Abhimano'ahankaarastasmadhvividhah:***

Self-potential--self-action-proceeds-polarisation

***pravarthathey rag.***

interactive spectrum.

***ekaadhashakaschagannas thanmaathra:***

elevenfold as calculated potential fieldforce

***panchakaschaiva.***

set of five

**Meaning:** Energy of an interaction is polarised into two aspects of self organised static potential and self- acting dynamic force that initiates the entire spectrum of energy interactions extending to a range of 11 steps whereas the static self potential and dynamic self-action ( or kinetic self-similar force or energy) form a balanced set of two factors which initiate action. In the dynamic self-action mode it expands in sequential steps to a limit of 11 sequential levels. Whereas the contracting static potential state reaches a limit of 5 sequential levels.

Explanation:

5 LEVELS  $8 + 3 = 11$   $8 - 3 = 5$ .  $11 + 5 = 16 = 8 + 8$

Internal state is 3 (Cubic or three axis synchronised)

Abhimano =  $8 - 3 = 5$  the superpositing of vibrations internally (magnetic count)

Ahankar =  $8 + 3 = 11$  the expansion by acceleration extenally (electric count)

The internal cycle has 4 levels . As shown in Suthra 23 1& 3 and & 4 willcombine

$1 + 3 = 4 = 2 + 2$  is balanced and next  $6 + 10 = 16 = 8 + 8$  is also balanced.

Secret Of Sankhya: Acme Of Scientific Unification.

But between 3 and 8 the balance is upset as follows

Thaama  $8 - 3 = 5$ .  $8 - 4 = 4$   $8 - 5 = 3$   $8 - 6 = 2$

$8 - 7 = 1$   $8 - 8 = 0$

Sathwa  $8 + 3 = 11$   $8 + 4 = 12$   $8 + 5 = 13$   $8 + 6 = 14$

$8 + 7 = 15$   $8 + 8 = 16$

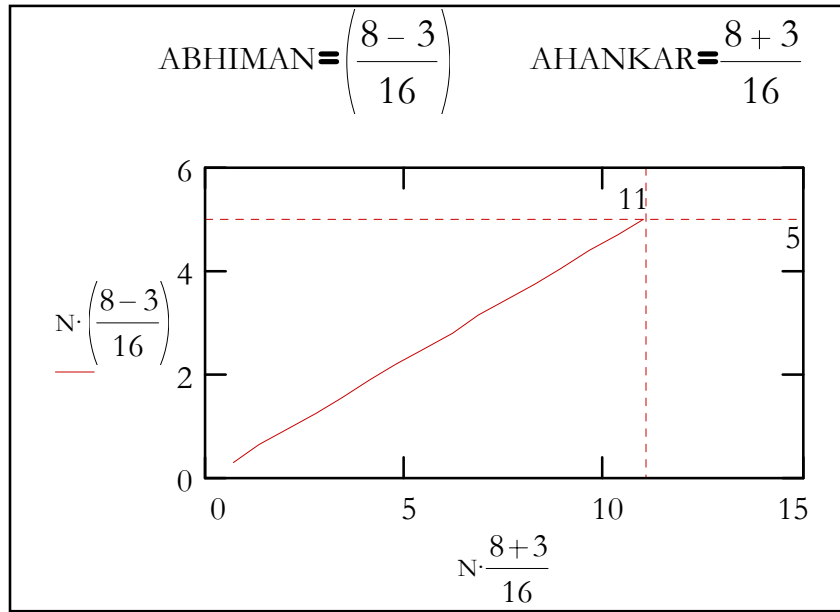

Fig: Abhimaan Ahankar Polarisation Graph

The count rate inwards decreases as it goes towards the first positon and increases outwardly. The potential difference gets less towards the centre and is a maximum at the unity cycle boundary.

$1 + 3 = 4$

$3 + 3 = 6$

$6 + 10 =$

$16$

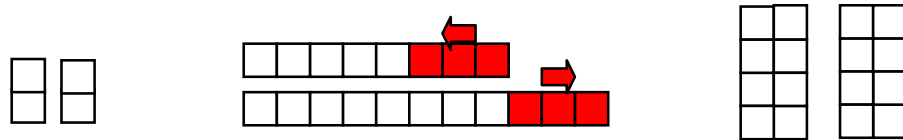

Fig: The Mahad Vikrithi Vrithi Polarisation State

$(2 + 2 = 4 = 2 \times 2)$   $(8 - 3 = 5 \text{ and } 8 + 3 = 11)$   $(8 + 8 =$

$16)$

## Secret Of Sankhya: Acme Of Scientific Unification.

(Yugapac state) (Abhiman and Ahankar state) (Vritti state)

(Oscillator) (electro-magnetic-state resonant-state)  
(photon)

This is an important theorem explaining the internal self-sustaining oscillation due to the permutation and combination of the Sathwa, Raja and Thaama Guna polarisation mode. The electromagnetic phenomenon is mathematically shown to be a vibratory interaction of the components of the substratum. This theorem explains the Maxwells electro-magnetic phenomenon in the simplest axiomatic way at the fundamental level in space. The above statements of axiomatic logic cannot be disproved and it holds good only if the substratum is composed of Purusha as the passive supportive components. It shows how the state of the components always combine to maintain a 1 by 2 relationship to maintain the oscillatory rate of C. It also shows that a radiated vritti or photon is initiated by an increase in its Sathwa internal stable count rate of C at the 8<sup>th</sup>.power to the 11<sup>th</sup>. power, equal to the electric field intensity, by an interactive shift in its internal rate from C to the 5<sup>th</sup>. power of Thaama rate that is the equivalent magnetic intensity or superposed or masslike state . It is a compensatory self similar exchange. Hence the Vritti or photon could be sustained to the extent of the 11<sup>th</sup>. power increase in rate. But a radiating Vritti or photon must have a self-sustaining form which could be ensured only by a minimum of two axis synchronising or acting simultaneously. Then the count increases to  $11+5 = 16$  the accelerated power index or 16<sup>th</sup>. power. Therefore it is the maximum number of counts that could be radiated at a time. If it increases from 16 to 24 by the third axis synchronising then the rate of count ransmisiion drops to zero because the potential or motivating action is reduced to nil as it becomes internal. From a position of two axis

## Secret Of Sankhya: Acme Of Scientific Unification.

acting simultaneously the potential is maximum but steadily decreases to zero when the 3<sup>rd</sup>. axis synchronises.

At the fundamental level that is always in a dynamic state there are two polarised states of internal dynamic activity. In the static or synchronised state, energy of selfaction is in the compressive or contracted thaamasic state and in the dynamic or kinetic phase it acts in an expansive or radiant satwic mode. The interactive rajasic state is an imbalance between these two states or phases, It is the cause of manifestation. The expansive phase forms an incremental sequence of 11 steps or states whereas the contractive mode reaches a limit of 5 levels. Because the creative interactive state is always in a dual state of oscillatory balance it is necessary to define it by a mathematical sequence that allows it. Odd states can never reach a balance . So a balanced state can be established if the sequence is always an integer number divisible by

two. Such a logic is ensured by the expression  $(N^2 + N) \times 1/2 = Y$ . Let us take the first pair of 1 and 3 to form the interactive state. The sum  $1 + 3 = 4$  and can be divided by 2 .  $2 + 2 = 4 = 2 \times 2$ .  $3-1=2$  and  $1+1=2$ . From Suthra 30 we learn that instantaneous interactions are multiplicative or logarithmic while sequential action is additive. The first combination  $1 + 3 = 4 = (1 + 1 = 2 = 3 - 1)$  has a unique characteristic. Product  $2 \times 2 = 4$  and sum  $2 + 2 = 4$  are equal. It means that at the level of the first combination the instant and period are both equal. In terms of the Guna interaction the compressive Thaama  $2 \times 2$  equals the expansive Sathwa  $2+2$ . The Raja Guna is zero ( $4-4 = 0$ ). Therefore the reaction is nil or there is no detectable time involved or the energy exchanged in the dual mode is equal. The interactive cycle is closed and self sufficient. No energy (force) etc is either absorbed nor radiated. it is instantaneous and not detectable because no energy transfer from or to an external source is involved. This phase is in

278

## Secret Of Sankhya: Acme Of Scientific Unification.

perpetual oscillation . This state cannot occur again because the product of integer numbers above 2 cannot equal the sum of such numbers and therefore the Rajasic state is not zero or the interactive state is manifest , exchanges energy with external environment and is propagative. It is level 1. If we take the next pair of  $3 + 6 = 9$  . It is not an integer number when divided by 2 and cannot form a stable state . It has to be confined or structured from external sources to remain in a stable state. It is AN odd sequence. It can combine internally. Then we take the next set 6 and 10. The sum is  $6 + 10 = 16$  and the sequence is  $8 + 8 = (6+2) + (10 -2)$  . It can be in a stable state. The product  $4 \times 4 = 16$ . The ratio of product to sum is  $16 / 16 = 1$  or the cycle is complete and but the duration is  $4 / 8 = 1/2$ . The relative energy level is  $1/2 \times 1/2 = 1/4$ . It is at level 2. The Raja state is  $(4 \times 4) - (8 + 8) = 0$ . Consider numbers  $10 + 15 = 25$  . Since the quotient is not an integer when divided by two it cannot be stable as it is an odd sequence. It can combine with others. But  $15 + 21 = 36$  and forms an equalised set of  $18 + 18$ . It can be stable and the ratio  $6 \times 6 = 36 = 18 + 18$ . The Raja state is  $(6 \times 6) - (18 + 18) = 0$  .

Secret Of Sankhya: Acme Of Scientific Unification.



**Suthra 25.**

Expansive interaction rises to 11<sup>th</sup>. Power

***Sathvika ekadhashakah:***

expansive elevenfold

***pravarthathe vaikrthadh ahankarath .***

initiating acceleration self-action

***bhuthaadhish thanmatra:***

elemental mass ; elemental vortex or particle

***sa thaamasas thajiasadh ubhayam.***

with contractive interactive both

**Meaning:** The expansive sathwik self active state has a set of eleven levels of accelerative change that creates elemental states with super-positioning modes and self sustaining units of activity or vortex. The compressive thaamasic change initiates through interactive combinations of both the raja and sathwa states.

**Explanation:** The expansive sathvik mode increases from its balanced internal oscillatory count rate of C at power index 8 (Suthra 22) to power index 11 (Suthra 23)  $8 + 3 = 11$  and is an accelerative radiating unit containing a selfsustaining vortex created by combinational interactions with the Thaama compressive state and Raja polarising modes.

$8+3=11$   $16-11=5$   $5+11=16$   $c^2 4\pi^2 / 7 = Vriti =$  photon The electromagnetic interaction leading to the radiation of a Vritti or photon is explained in this Suthra. The normal internal interaction is balanced within a unit cycle time but the Raja interactive state combines with the Thaama state to increase the Sathwa acceleration sufficiently to allow the radiation of a Vritti or photon. It means that the cycle time must be greater than circumferential period . The balanced period is given as 7  
281

Secret Of Sankhya: Acme Of Scientific Unification.

units or  $8 - 1 = 7$  but the vibrations along the two axis must increase its rate to exceed the radius to circumference ratio of  $2 \pi$  along both axis at the same time. That  $(2 \pi \times 2 \pi) = 4 \pi^2 = 39.48$  times normal rate at the cycle time when the Thaama superpositioning density rises to its maximum level. The timing logic is dealt with in Suthras 65 to 68 and the time involved gives an acceleration rate consistent with  $5.64 \times C^4$

**Suthra 26.**

Efferent and afferent sensory systems.

***buddhindhriyani chaksu:***

sensory-responses observable;

***srothraghraanarasanaspashanakani.***

sound-smell-chemical-contact-defined

***vakpanipaadhapaayupasthan***

oscillatory, interactive exchange transporting

expell or radiate regenerate or create

***karmendrayanyahuh.***

action responses defined

**Meaning:** Efferent or input sensory responses are light, sound, smell, chemical (taste) and contact (touch) and the afferent output or action responses are defined as oscillatory (speech), exchanging (grasping), transporting (walking), expelling (excretory) and creative (regenerative) functions.

**Explanation:** This verse identifies the human efferent and afferent sensory responses as an extension of a generalised principle arising out of the classification of five levels of externalised incremental changes resulting in these responses. It applies to all manifestation processes, including humans, organic and inorganic spectrum. The five levels are dealt with in later suthras at the relevant interactive level. Broadly, the volumetric interactions create changes in density in three modes which have the effects listed above. Sight is affected by the linear characteristics of radiation, hearing by the surface characteristics of a moving field of air, smell by the vapourous or ionised state of objects, taste by the chemical characteristics and touch by the thermal or vibratory state of objects. The human senses establishes the connection with phenomena and thereby identifies its nature and characteristics. While most

283

Secret Of Sankhya: Acme Of Scientific Unification.

translators have interpreted Sankhya as applicable to human problems, in reality it is about universal forces.

**Suthra 27.**

Interactions in the sensory systems.

***ubhayathmakamathraman***

duality in internal functions in effect – mind

***sankalpakamindriyam ca sadharmayath.***

Autonomous-control-senses also resembles

***gunaparinamavisheshaananathvam***

interactive-exchange-gunas-spectrum-variety

***bahyabheddascha .***

external-interactive-exchanges

**Meaning:** Mind or the cerebral system is capable of processing both the efferent or incoming input sensory information and afferent or outgoing action oriented outputs and it can produce a specific output despite the diversity created by the permutations and combinations of the internal aspects of the three gunas with the numerous external incoming signals.

**Explanation:** The cerebral process is defined as functional process common to all aspects organic life. It is depicted as a processing system that interactively deals with both incoming and outgoing information through one guna combinatorial law . It is capable of combining complex multiple inputs to process interactively and output a unified or varying result for initiating action. It again is a generalised theorem of a universal process of cerebral functions and includes humans too.

The universal process of thinking is shown graphically. The two interactive states of afferent and efferent process follow the guna interactive laws. While the human process of thinking is more complex, other organic living entities

284

Secret Of Sankhya: Acme Of Scientific Unification.

too follow the same principles. Information is collected, interpreted and activated in the same manner. The sensory systems as developed are in response to the laws of nature and governed by the Guna principles of interactive exchange.

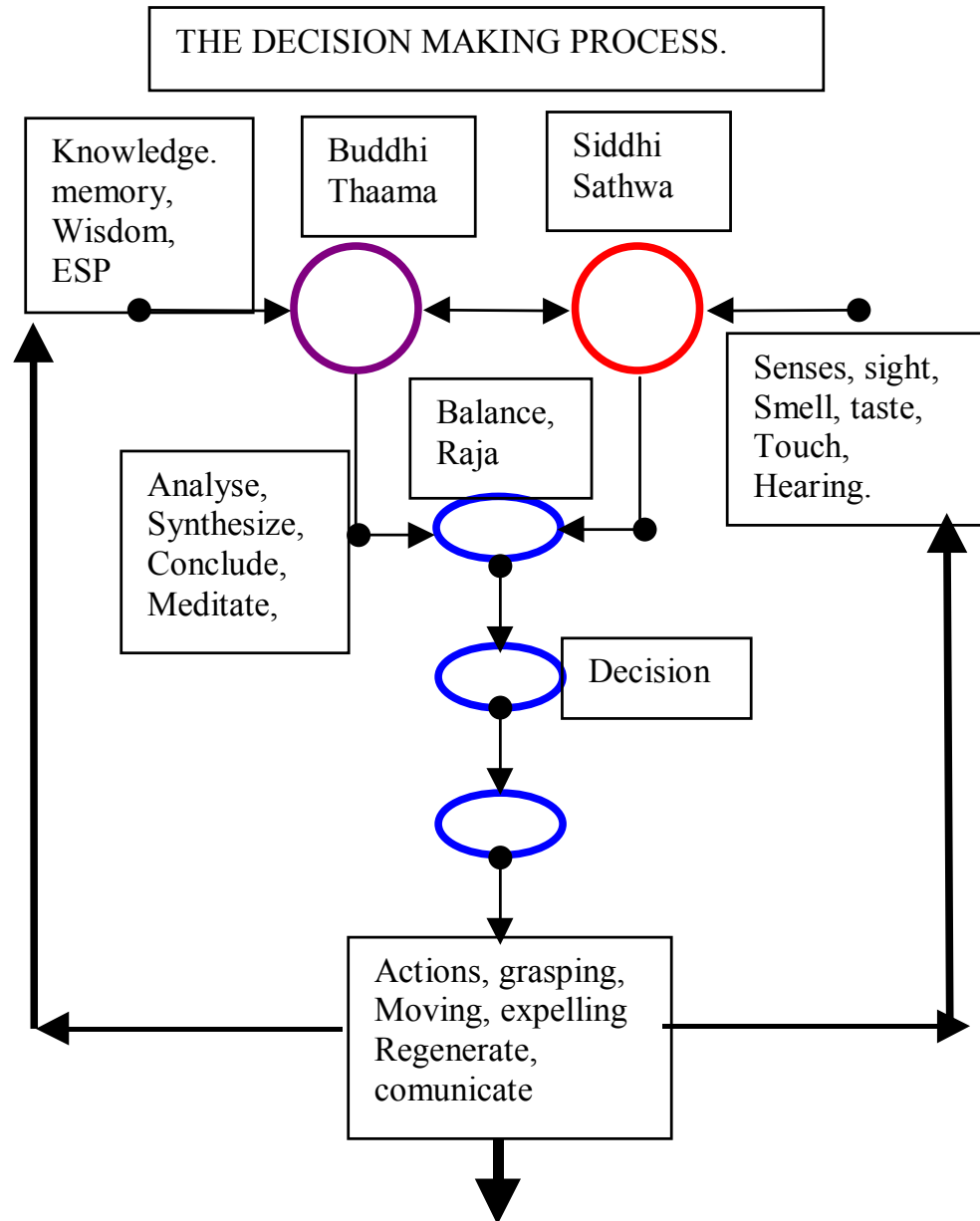

Fig. The Cerebral Process Based On Gunas.

Secret Of Sankhya: Acme Of Scientific Unification.

**Suthra 28..**

The five levels of vrithi activities.

***shabdadishu panchanam-***

sound-onwards sequence of five

***alochanamatramishyate vritti.***

observable-measure-of-action vortex

***vachanadhanaviharanothsargaanandhascha***

oscillatory-interactive-transporting-radiation-regeneration

***cha panchanam***

are sequence of five .

**Meaning:** The five types of sensory input signals are activated by discrete quantum of forces and it results in five categories of output as oscillatory, interactive, transporting, radiating and creative activities.

**Explanation:** The spectrum of outputs from a processed input consisting of information received as sound, light, smell, taste or touch through its respective interactive processes results in outputs that generates sound oscillatory reactions as speech. Light, smell, taste and touch related information received in its respective forms stimulate responses that relates to grasping, locomotion, expelling and regenerative functions. The above process relates to all formas of life which also relates to human responses. The concept behind Suthra 27 and 28 is that the cerebral process is an organised system to deal with information functions that come from the interactive field of phenomena. The cerebral system is a response-related reactive system that immediately processes action-related information logically and correctly to initiate activity at the right level, within the required time. The five sensory signals are in real terms the state of the field in space. It is affected by the nuclear core state and the numerical

286

Secret Of Sankhya: Acme Of Scientific Unification.

derivation would be carried out after the 68<sup>th</sup> Suthra that defines the perpetual oscillatory process.

**Suthra 29.**

Definition of self similar internal activity and radiation

***svalakshanyam vrittistrayasya***

self-similarity cyclic-vortex-third-power

***seyisha bhavathyasamanya.***

yet moving together functions-in-different-modes

***samanyakaranavrithi :***

synchronously-acting-cyclic-vortex

***praanaadhya vaayava: pancha.***

energy-current radiation-unit fifth-power.

**Meaning:** The cyclic vortex functions on self similar principles upto the third power , is nonsynchronous, and yet interacts internally together in an various way. But in the synchronous accelerated state at the fifth power it becomes a fundamental unit of energy radiation.

**Explanation;** The internal cyclic interactions upto the third power functions on self similar principles that is in a resonant manner. The synchronous non-spherical –ovoid –torroidal shape of a Vritti or photon is created by accelerated or increased count rate along two axis simultaneously, equal to  $(2 \pi)^2$  as it has to radiate outwards and that equals the fifth power. That is the third power is volumetric and surface acceleration adds 2 orders to total 5. Again, the generalised principle of vorticullar functions applies to all levels. The derivation depends on the 68<sup>th</sup> Sutra and has wide ramifications covering the entire spectrum of manifestation. Spherical harmonic oscillatory follow self similar interactive rules and is covered mathematically



Secret Of Sankhya: Acme Of Scientific Unification.

**Suthra 30.**

Definition of a cyclic vortex and a spherical harmonic oscillator.

***yugapacchathushtashya*** ***thu*** ***vrithi:***

instantaneous-cycle-fourth power applies-to cyclic-vortex .

***kramasascha thasya nirdhishta .***

sequential consequently detection .

***drishtey tathapiadrishte trayasya***

manifested similarly-such-unmanifest third power

***tatpurvika vrithi.***

Previous-source cyclic-vortex

**Meaning:** When the oscillatory cycle count in all directions act simultaneously or synchronously and is raised to the 4<sup>th</sup>. Power, a cyclic self-supporting vrithi (photon) is formed. When it acts non-synchronously or sequentially and it becomes detectable and measurable with a degree of certainty. In the initiating state prior to the above when the oscillatory count reaches the power of three and is synchronised and acts simultaneously in all directions , it is in a self supporting harmonic oscillatory state but is not detectable or observable.

**Explanation:** Instant  $1/x =$  sequence  $1+x$

Principle of Simultaneity. (instant or inelastic or colliding interaction) thaamasic

Principle of Relativity (sequential or elastic or moving or rebounding or radiating interaction) is satwic

Principle of Resonance ( resonant or shuttling or bonding or balancing interaction) rajasic

Prior or internal state

Thaama (product of interaction) – ( Sathwa (sum of reactions) + Raja (resonant))= 0

sequence =  $1/x = x/x^2 = x^2/x^3 = x^3/x^4 = x^4/x^5 = x^5/x^6 = x^6/x^7 = x^7/x^8 = 1 + x$

Secret Of Sankhya: Acme Of Scientific Unification.

Vrithi Balanced oscillator  $2^4 = 16 = 8 + 8 = 2^3 + 2^3$

Product equals sum.

Starting point of detection of activity

Yugapach (Simultaneous)  $2 \times 2 \times 2 \times 2 = 16$  .

Kramasa (Sequence or Periodic)  $8 + 8 = 16 = (2 + 2 + 2 + 2) + (2 + 2 + 2 + 2)$

Yugapach / kramasa  $4 / 4 = 1 =$  Resonant static state

Purvika vrithi 3.  $2^3 = 8 = 4 + 4$  internal resonance

Simultaneous interactions model—the interactions inside the earth or sun that's acting as unit. Or the self energy inside a proton or electron or photon etc. are all simultaneous.

The volumetric expansion by doubling radius is 8 but its area increase is 4. The density change is 8 but the area flux density change is only 4 and the difference creates an inequality that initiates accelerative changes.

Secret Of Sankhya: Acme Of Scientific Unification.

**Suthra 31.**

The principle of self-similarity is the cause of perpetual internal oscillatory state.

*svam svam prathipadhyanthe*

self-similar self-organised all the way to the end

*parasparaakuthahethukam vrittim.*

Mutual-interactive-exchange-selfmotivated- cyclic vortex

*purashartha eva hetur*

nuclear potential only motivating impulse

*na kenacit karyathe karanam.*

no other motivating potential cause

**Meaning:** The cyclic vortex or spherical oscillator is kept in continuous interactive exchange upto the very end (limit) only by the nuclear or core potential developed by the mutual exchange of internally motivated and triggered self similar and self organised impulse or force and there is no other external potential cause.

**Explanation:** The Principle of self-similarity is explained as an internal interactive exchange that exists perpetually and the potential to motivate it is developed by triggering the two internal states of compression and expansion in mutual exchange process of coherent potential to kinetic movement. The perpetual oscillatory state (Sutra 68) is self supporting, self controlling and self organising . Hence there is no external cause except the balanced cyclic exchange of compressive and expansive interactive states carried out in a way to exchange the two modes of activity following self similar rules of interaction.

$$1+x = 1/x : (1+x)^n = 1/x^n : (.5 - x^3/2) / (.5+x^3/2) = x$$

**Suthra 32.**

The static and kinetic potential limits.

***karanam thrayodashavidham***

potential-cause thirteenth power

***tadhaaharanadhaaranaprakaashakaram .***

in-which-it-accelerates-superpositions-radiates

***karya cha tasya dashadhaahaaryam***

kinetic-activity consequently is tenth-power -acceleration

***dhaaryam prakashyam cha .***

superpositioning radiation also.

**Meaning:** The potential rises to the 13<sup>th</sup>. Power to accelerate superpose and radiate. Consequently the kinetic interactive rate rises to the 10<sup>th</sup>. Power to accelerate, superpose and radiate.

**Explanation:** The self similar compression or superpositioning factor  $1+x$  applied to the normal oscillatory state of the substratum raises it to the 13<sup>th</sup>. power from its expansive and radiant state of  $c$  raised to  $1-x$ . The numbers are log index.

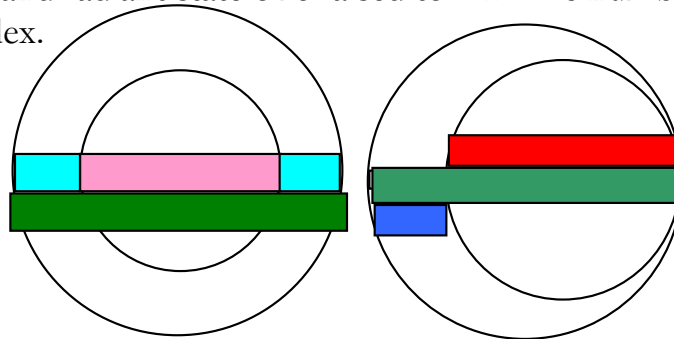

Green=  $8+8=16$ . Red= $10+3=13$ . Blue= $3$   
. Pink= $5+5=10$ . Light-blue= $3+3=6$

Fig: The Radiation Phenomenon

The green 16 represents the interactive value of  $C^2$  in the resonant Raja state. In a balanced state the coherent,  
294

Secret Of Sankhya: Acme Of Scientific Unification.

perpetual, self similar interaction polarises the internal state into light blue 3 the expanded Sathwa state and the pink 5 Thaama state. Due to an impact from a neighbouring component its light blue 3 adds to its existing value as  $5+5+3 = 13$ . But that shifts the balance from the previous centred state to blue 3 and red 13. Therefore the red 13 acts as a simultaneous coherent unit and transfers the extra 3 to the next unit and returns to its original balance state. The easily understandable process of transference of counts to radiate phenomenon is portrayed with extreme clarity. Converting it to values in physics shows how the electromagnetic phenomenon functions. Using C as the velocity of light the following numbers emerge as axiomatic values, for C is derived .

$C = 296575967$	$C^x = 1.7221381E+5$
$C^2 = 8.79573E+16$	$C^{1+x} = 5.10744E+13$
$C^3 = 2.6086E+25$	$C^{1-x} = 1.722E+3$
$C^{x-2} P_x^{1/2} = 8.9612E-12$	$1/C^x P_x^{1/2} = 1.268E-6$
$4 \pi / C^{1-x} = .007297$	$1/(C^{1+x} k rs)^2 = 2.319E-28$

Explaining the equations,  $\log C^2 = 16+$ ,  $\log C^x$  is  $5+$  and  $\log C^{1-x}$  is  $3+$ . The well known constants, permittivity epsilon, permeability mu, the electromagnetic coupling alpha and lastly the electron charge in mks units are shown by the side of the Aharana, Dhaharana Prakashyam and Karanam values all axiomatically derived. Physical measurements are affected by the simultaneous coupling constant  $P_x$ , (not derived because it is hidden) and the 295

## Secret Of Sankhya: Acme Of Scientific Unification.

equivalent values are shown as a rigorous logical derivation.

When two counts act simultaneously in less than  $1/C^{1-x}$  of a cyclic period the two act as one and reflects as the increase in mass. Hence charge beyond  $(C^{1+x})^2$  changes into a mass value. The same equivalent value is derived in general relativity too to indicate a mass value in terms of displacement/length.



Secret Of Sankhya: Acme Of Scientific Unification.

**Suthra 33.**

The internal and external potential limits.

***Antha: karanam thrividham***

the limit of potential third power

***dashadhaa baahyam thrayasya vishayaakhyam***

tenth power external triad detectable-defined

***saamprathakaalam bahyam***

present-sequential-time external

***thrikalamaabhyantharam karanam.***

Third-power-of-time-internal bonding

**Meaning:** The internal limit of potential is at the third power and the externalising detectable factor defined as existing in present time is upto the 10<sup>th</sup>. Power. The third power factor contributes to internal bonding or it is a limit .

**Explanation:** The expansion is effected by the 10<sup>th</sup>. power factor when the interaction is externalised in real or current time. The third power imposes a limit on the the interactive state as a limiting or damping force that cannot exceed the 13<sup>th</sup>. power superpositioned state. The internal limit is reached when the third power of the time interval is reached. Length L equals velocity into time. Volume is L cubed. If velocity is maximum then time will be the minimum. Therefore in a real field of space of L cubed volume the dynamic change is velocity cubed. Therefore time cubed becomes the minimum. That is any time less than time cubed becomes the limiting number. A point in space can be described by time cubed under the defined circumstances.

Secret Of Sankhya: Acme Of Scientific Unification.

**Suthra 34.**

The potential to act is at the 5<sup>th</sup>.power level.

***buddhindriyaani tesham pancha***

motive-sensory-signals increase to fifth power

***visheshaviveshavishayaani.***

specific-nonspecific-phenomena.

***vagbhavathi shabdavishaya***

speechforms relates to sound vibrations

***sheshani tu panchavishayani .***

Remaining concerns all five forms of phenomena.

**Meaning:** The internal potential to act increases rate to 5<sup>th</sup>. power of both the specific and non specific or the observable and the hidden sensory signals. Sound signals relate to speech or oscillatory sound functions whereas the rest relate to all the five observable interactions.

**Explanation:** The senses respond to the five grades of signals or stresses from interactive states. While the signals are received by the respective organs, the interpretation of all are carried out by the Buddhi, simultaneously. Sensory inputs are received sequentially but the interpretation has to be carried out at the same moment for all the different variety coming in, if its consequences are to be realised and understood meaningfully. The sounds of the alphabet are heard one after the other but the meaning of the collective alphabet as a word is decoded by the Buddhi, by analysing all of it simultaneously.. Hearing the letters of the alphabet one after another as c a t has no meaning unless it is realised by the mind that it is the name of a feline animal. The Buddhi carries out the simultaneous comparisons and compares with memory to give reaction in a meaningful way. All the other sensory inputs to follow the same procedure. The cerebral system to reacts to phenomena in the same way as any organic or inorganic systems do.

**Suthra 35.**

The formation of a basic field is determined by the 3<sup>rd</sup>.  
Order damping action.

***santha: karanaa bhuddi :***

internal interaction coherence

***sarvam vishayam avaghahate yasmath.***

all phenomena plunges-to-a-point forcefully

***tasmath trividham karanam dvari***

therefore third power bonding medium

***dvarani sheshani.***

user of medium the remaining powers

**Meaning:** At the point when all measurable interactions plunge to its limit of stress and form a coherent bond it is a measure of the effort involved and therefore the third power of this bond forms the base or medium , the remaining powers of interaction use this as medium.

**Explanation:** The coherent level creates the static state that allows the other non coherent states to plunge or accelerate towards it and stays with it to form a bond. The third power of the interactive rate forms a limit and all such states become the base or ground level to become a medium, on which the remaining states interact using it as a medium.

It is an explanation for the observed attractive gravitational action. All vibratory or oscillatory states remain together at one place or in a bound state when all three axis have the same rate. A higher rate of vibrations on an object will move towards the one with a lower rate and interactively exchange to equalise or attain an equilibrium state to stay bound or in one location.only

**Suthra 36.**

Decay of radiated phenomenon.

*yethy pradhikalpah :*

spectrum radiation-decay-process

*paraspara vilakshana gunavishesha:*

mutual complex guna specific

*kritsnam purushasyartham*

total Purusha potential

*prakashya buddhau prayachhaanti.*

manifest coherent action controlled-final-end

**Meaning:** Spectrum of light transmission process is a complex and mutually interactive guna exchange sequence and it is totally controlled by the Purusha potential and it is the only coherent motivating factor clearly till its end.

**Explanation:** Radiated phenomenon must decay because it is motivated only by the Purusha potential which has a specific limit.

The complete spectrum of light is transmitted by the mutually interactive complex guna process and the entire manifestation sequence is wholly or only due to the Purusha potential and it provides the motivation for it till its end. It shows light decays and the motive is provided till its end. The formulation below is extracted from later Sutras where these parameters are derived

$$C^2 \times (4 \pi^2)/7 = Mps / (my \times c^3 \times k)$$

Secret Of Sankhya: Acme Of Scientific Unification.

**Suthra 37.**

Extraction of potential energy from the Purusha domain.

*sarvam pratyubhogam yasmath*  
comprehensive extraordinary use forcefully  
*purushasya saadhyati bhuddhi.*  
Purusha-potential attainable coherent potential  
*saiva cha vishinishti puna:*  
with also precise trigger input repeated  
*pradhanapurushantaram sukshamam.*  
interactions inside the Purusha minute

**Meaning:** A comprehensive and extraordinary use can be made in the following way. The potential of the Purusha can be attained from the minute coherent state hidden inside the Purusha by repeated precisely triggered inputs to initiate the primary interactions.

**Explanation:** Potential energy can be extracted from within the hidden interior Purusha domain by a process of repeatedly triggering the primary interactive region with a minute or sharp or impulse or triggering an input of energy. The mathematical formulation is derived in the last few Sutras. The perpetual oscillatory state can be upset by a triggered impulse which then releases a large amount of energy during the process of regaining its harmonic oscillatory state.

Secret Of Sankhya: Acme Of Scientific Unification.



**Suthra 38.**

Classification of activity of virthi and elements

***thanmathranyavisheshastebhyo***

self-generated vortex-non specific-order

***bhuthani pancha panchabhya.***

element five fifth order

***yeta smrita vishesha :***

spectrum law species

***shantha ghorascha muddasca.***

synchronised interactive-and superposed

**Meaning:** The self-generated vortex or vritti has a non specific or wide range of activity level while the elements are at five levels upto the fifth power of activity . The spectrum logically covers the classes of activity states defined as synchronised, non synchronised / interactive and superposed / coherent .

**Explanation:** The self generated vortex covers a wide range and are not confined to any specific order . The elements cover a distinct or specific sequence of five levels rising upto the fifth power and it is classified in three specific groups as follows. When all the three axis synchronise and act together in a coherent mode it displays high inertial qualities of massive and ponderous action . The two axis synchrony is highly interactive and covers a wide range whereas the linear activity confined individually to a particular axis has a linear, laminar and synchronised mode of action.

**Suthra 39.**

Genetic code.

***sukshma matapitrajah:***

field            organic

***sahaprabhutaistridhavishesha: syu:***

sustained-energy-source-triple-species bond

***sukshmastesham niyatha matapitraja nivartanthe.***

mobile field            constant organic            cyclic

**Meaning:** The field sustained by the fundamental source of energy bonds into three organic species. The mobile field is constant and controlled and the organic states of three species are cyclic or periodic.

Explanation:

The 23.5 interactions per cycle (ipc) is a fundamental rate of oscillation within a confined or closed shell. The transition from 23.5 to 259 ipc at the surface gives the transition region. At 23.5 the left and right handed spins or oscillatory transmigratory movements are combined. The charge differentiation does not exist below 23.5 ipc but polarises beyond it upto 259 and has its distinct characteristics established beyond c. Hence similarly molecular, genetic and other 'single' body units below 25 ips will not display any difference. A virus state is a state below 23.5 and has no sex characteristics. Beyond it the 'handed' difference is exposed and male / female classification commense. In spontaneous regeneration from space at the correct environmental conditons a sexeless virus state can metamorphosise into any sex characteristics. (A particular variety of frog has been discovered alive deep inside a stone when broken.)

**Suthra 40.**

Linga state as coherent and superposed oscillations.

*purvothpannamashaktham niyatham*

source fallen not bound subdued

*mahadhadhisukshamapariyantham.*

forces intense to subtlefield at extreme limit

*sansarathi nirupabhogam*

spectrum absolute absorption

*bhavair adhivasitham lingham*

chargeforms superpositioning mass-characteristics

**Meaning;** Static mass states are created by maximally absorbing and superpositioning the entire spectrum of vibratory or oscillatory states, from the largest and strongest (to the limit) finest, minutest kinetic charged states.

**Explanation:** The Linga state is a superpositioned state.

When two states superpose or act simultaneously, the interactive count of two merges and the count reduces to one but with an increase in its mass. The higher interactive counts drift towards the reduced count state. It gives the illusion of attraction towards an increased mass state.

When displacements due to an interactive change is at a faster rate than the normal balanced interactive oscillatory state, it piles up (one on top of another) and many act at one time or simultaneously giving the effect of an increased force, from the same component unit. Within the period of a cycle the Linga state retains its value permanently thereby giving the superposed state a continuous and permanent value of increased quantum termed as mass or rest mass in physics. Though superposed and mass increases the counts get reduced by

307

Secret Of Sankhya: Acme Of Scientific Unification.

synchronising and therefore forms a state of lower activity that allows higher interactive rates to drift towards it and get absorbed. The change over point is shown below, where  $n=21$ .

Equation S40. When the interval is less than the stress value the counts are absorbed or two axis act simultaneously.

$$\begin{aligned} (A_n)^2 &= 2.24408823 \cdot 10^{-14} & (A_{n+1} \cdot 2)^2 &= 2.24408823 \cdot 10^{-14} \\ \left[ (A_{n+1} \cdot 2)^2 - (A_n)^2 \right] - (c^{1+x})^{-2} &= -2.57129314 \cdot 10^{-28} \end{aligned}$$

Secret Of Sankhya: Acme Of Scientific Unification.

**Suthra 41.**

The need for the substratum as supporting framework for manifestation.

*chitram yathaashrayamrithe*

picture for instance-support-framework

*sthanvadibhiyo yatha vina chaaya.*

Post for instance without shadow

*thadvina visheshairna*

so without specific -not

*thishathi nirashrayam lingham.*

as required without resting place synchronised state

**Meaning:** Just as it is not possible to present a picture without a supporting base nor cast a shadow without an appropriate post, so also it is impossible to have the synchronised and superpositioned coherent state without the required supportive base.

**Explanation:** This Suthra emphasises the logical need for a supporting base . An object does not need a support as it has an existence on its own due to its structure or contents. But a drawing must have a paper or canvas or supporting framework of some kind that would be used to project the drawing. A shadow by its very nature is dependant on an object to obstruct light , only then it is cast . Hence it must be understood that a Linga state is not an object in itself but it is the accumulation or collection of vibrations or oscillations from a previous interactive state of Bhava activity , which seeks a “rest“ or inactive state with relation to its location and therefore it must belong to something that is existing or substantially verifiable. The base must be real or it must have substance. The substratum as described in the very first Suthra is necessary to provide the supporting framework. Such a base is necessary as a mathematical reality to proceed with the

309

Secret Of Sankhya: Acme Of Scientific Unification.

logic enumerated so far. Manifestation is a hologram built up of vibrations of elemental components.

**Suthra 42..**

The synchronised state provides attracting potential to build up mass.

***Purusharthahetukamidham***

nucleur-potential-motivating-attraction

***nimithaneimitthikaprasangena.***

to-this-target-circumferentially-incidentally-attachment

***prakrithairvibhuthvayogannatavadvyatishtathe.***

Oscillatory-action-strongly-resonant-dancelike-exchange

***Lingham.***

superpositioned mass

**Meaning:** The synchronised and coherent state of the nuclear core forms the target potential to attract the oscillatory interactions to synchronise and superposition itself circumferentially, simultaneously, similar to the movements in a dance, that increases and strengthens the resonant state of the interactions .

**Explanation:** The build up of the Linga characteristics of mass is explained in a picturesque way to illustrate the mode of action. Mass in an object is a permanent increase in its density. But in the substratum the mass is built up by the occupation of oscillatory displacements on the same component location on a time sharing basis. This as an important theorem that explains the most fundamental nature of a movement. When action and reaction in a self similar interaction of equal components in the substratum is not balanced or the cycle period is not half, then there is a drift or movement towards the direction of the delayed reaction and as the interactions pile up and accumulate the delay increases thereby causing a chain reaction of movement that forms or becomes the nuclear centre with mass or inertial linga characteristics. the original interactions or bhava state that had equal spatial

311

## Secret Of Sankhya: Acme Of Scientific Unification.

displacements in both directions in maintaining a balance, now experience a reduction in displacement and an increase in the cyclic period in the region towards which it has drifted and as a result more than one displacement or interactive exchange is forced to occupy the same location. The Suthra makes it clear that it is a an incidental or superficial attachment or super-positioned state. This action of many interactive displacements occupying the same location in the same period is a time sharing act of superpositioning like when two dancers occupy the same place by stepping in harmony at different but equal fractional intervals. If there is a misstep the harmony is broken (see note 2.). Because of many interactions occupying the same place the reactions behave as though many components act reactively at the same time or simultaneously or coherently or synchronously. The effect is a multiplication of the reactive value or an increase in the mass or linga characteristic of the core and now the core acts unitedly or as one unit and displays centre of mass characteristics. Its an ensemble or collection of components acting in unison. Whenever the activity along the axis synchronises in rate with an axis in another direction superpositioning takes place along the circumferential position simultaneously on all sides. Two axis synchrony gives a united surface of activity with a flexible centre of mass which typically is the electromagnetic behaviour in a fundamental field and the liquid / fluid status in a molecular field. Three axis synchrony provides the solid phase behaviour and a particle with a dense and fixed centre of mass characteristics. In a three axis synchronisation the interactive counts merge and reduce which then provides a lower count state towards which the higher counts drift giving the effect of attraction, inward acceleration etc. Effects of Gravity and electromagnetic acceleration are caused by the same principle.



Secret Of Sankhya: Acme Of Scientific Unification.

It is important to understand that mass characteristics in the substratum, in a state of kaivalya or freedom, can be generated only by coherent, synchronised, superpositioned states

Equation S.42. The synchronisation creates PM the Prakrithi Saptha or Nucleon.

$$\text{PM} = 1.67442318 \cdot 10^{-27}$$
$$\frac{K_x}{c^3 \cdot \left[ \sqrt{\left( Z^n \cdot A_n \cdot 2 \right)^{-2} + \left( Z^n \cdot A_n \cdot 2 \right)^{-2} + \left( Z^n \cdot A_n \cdot 2 \right)^{-2}} \right]^3} = \text{PM}$$

**Suthra 43.**

Conditions under which the Laws of interaction are certain.

***samsiddhikascha bhava***

state-of-resonance-also charged state

***prakrithika vaikrthascha dharmadhyā:***

oscillatory accelerative activity are the start of axiomatic laws

***dhṛsta: karanaashrayinah***

detection reaction-resting-place

***karya-shrayinascha kalaladhya.***

action -resting place start of time or cycle count

**Meaning:** The source or starting point of the axiomatic laws of resonant action are from the state when the charged interactive state is in a state of perfect resonance and the starting point or start of time-cycle-period count of measurement commences when the action is in a state of relative rest or static state for detection is only possible when the detected component is at a restful state.

## Secret Of Sankhya: Acme Of Scientific Unification.

**Explanation:**  $1+x = 1/x$   $x-(1-x) = x^3$ . The fundamental laws of interaction are correct or valid only for the coherent state, meaning that the rules of logic can be applied correctly when the active state is steady and unchanging. If a calculated value is to be ascertained it can be expected to be correct only for a resonant state that holds for the duration of that cycle. Similarly when measuring or detecting an interactive state the observer can synchronise or count or time an activity from the position at which it is relatively stationary or seems to be resting. Counting the number of bounces a ball makes can be correct only if timing of the count is synchronised when the ball hits the floor. This Suthra defines the certainty of detection or measurement in a dynamic state of components. There is a possibility of uncertainty of measurement and also loss of proportionality of interactive rules if the stated conditions are not observed. It also has serious ramifications in theorising. The substratum is not detectable for the reasons given above. For instance a foot rule with markings in tenths determines the accuracy to a tenth. As a result of this theorem the two important parameters in an oscillatory state is defined. Assuming an interactive count of ten per cycle along an axis and it interacts with a similar axis count of an adjacent unit then it will increase to 10 into  $10 = 100$  counts but if the two are to maintain the restful state of remaining in the same position then it must distribute the 100 as equal counts of 50 along each opposing axis within the cycle. If not the excess that continues beyond the cycle will cause unsynchronised count states at the interactive point. Equation S.43. There are three locations at which measurement of parameters can be made or observed.

$$\frac{Kx}{c^3} - PM \cdot Px = 0 \quad my \cdot c^3 - Ne \cdot c \cdot \left(\frac{7}{2 \cdot \pi}\right)^2 = 0$$

$$\frac{Pm}{\left(\frac{7}{k-1}\right)^2} - \left[ Me \cdot \left(\frac{10}{2 \cdot \pi}\right)^2 \right] = 0$$

The Linga/Bhava interface of the Purusha Kx and Prakrithisaptha PM interactive level in the strong force region provides a stable state called the Compton wavelength in physics. The next mid level Raja resonant balancing point of the Prakrithisaptha PM and Mahadvikrithi Me is where almost all manifest phenomena remain in a stable / bonded state. The Proton/Electron interface or hadron / lepton weak force region is a complex one. Next the MahadVikrithi Me to Vikrithisaptha Ne change takes place in the Abhiman/Ahankar interface where the accelerative Vikaro state radiates 7 Ne as a Vrithi or Photon. The unmanifest state of zero is an indicator of a self similar oscillatory activity in perfect balance when there are no inputs but an unbalanced state triggers this state into a reactive response. The zero state is kept in balance by Ne transmigration in a tunneling mode and only when 7 Ne are triggered simultaneously a detectable vrithi or photon is radiated.



**Suthra 44.**

The mode of natural action based on rules.

***dharmena gamanamurdhvam***

axiomatic laws leads-upward

***gamanamadhastadbhavathyadharmena.***

leading to lowering of actions opposing natural law.

***jnanena cha apavargo***

self-potential cause of state of coherence

***viparyayadishyate bhandah.***

reverse results in restrictions

**Meaning:** Sathwic expansive actions are supported by axiomatic laws and leads upwards or towards a free state but actions opposing it results in lowered states that leads to thamic or compressive states that are restrictive. Inner self potential is the only cause of synchronisation and establishment of a coherent state but obstruction or restrictions results in a confined and bonded state. Self potential is created by merging or synchronising, reducing time of activity or work.

**Explanation:** The natural self similar laws support an expansive or upward or free states of synchronous and harmonised states of existence of interactions. Opposite states leading to compressive or confined states, require the action to oppose the natural mode. Coherent synchronised states are created by the inner self potential Equation. S.44. Self similar expansion can continue without limit.

$y := \frac{\sqrt{1+2^2}-2}{2}$	$\frac{\frac{1}{2}+y}{\frac{1}{2}-y} = 1.61803399$	$\frac{\frac{1}{2}-y}{y+y} = 1.61803399$
$\frac{1}{\left(\frac{1}{2}+y\right)}$	$\frac{1}{2}$	$y+y$

Secret Of Sankhya: Acme Of Scientific Unification.

Equation .S.44.A. Reducing or restrictive series end at the 3<sup>rd</sup> power.

**Suthra 45**

State of unbalance is the motivating cause of manifestation.

*vairyagath prakrithilaya:*

neutral state absorption of activity

*samsaro bhavathy rajasadragath*

manifestation forms resonant-spectrum

*aisvaryadavighatho viparyayath tadviparyasah.*

Power-acceleration reversal and its opposite

**Meaning:** When the rajasic interactive states are equal and balanced accumulation or increase of mass by absorption or superpositioning of active displacements occur. When unbalanced or unequal the increase or decrease in force causes acceleration or deceleration creating the manifest spectrum of universal phenomenon.

**Explanation:** A state of balanced interaction is one that simulates a static or stationery condition and as a result all interaction drift or move towards such a condition thereby increasing its potential by superpositioning the interactive displacements by absorbing it in the same location, which increases the density or mass of that state. Therefore any location that is in a synchronised and balanced interactive such that it seems to relatively stationery or static, it attracts or causes other interactive states at a greater level

$$\left(\frac{1}{2} + y\right) - \left(\frac{1}{2} - y\right) = 0.23606798 \quad \left(\frac{1}{2} + y\right) \cdot \left(\frac{1}{2} - y\right) = 0.23606798$$
$$\left(\frac{1}{2} + y\right)^3 = 0.23606798$$

## Secret Of Sankhya: Acme Of Scientific Unification.

along all the 3 axis of spatial configuration , so the position at which it occurs remains centred and stationery , which results in a spherical surface of activity being presented.

Also another important change takes place when the axis synchronise. The activity reduces to a coherent synchronised level that makes it an action centring state. Assuming that each axis has a count of 10 interactions per cycle and all the 3 axis are not in a synchronous state. The total number interactions per cycle will be 1000. If 2 axis synchronise the count will reduce to 100 and will present only 10 counts when all three axis synchronise. Assuming that all the surrounding components were at 1000 counts prior to this event, on one synchronising, all the 1000 count units will be now interacting with a 100 count unit whose reaction interval will be 10 times as long. Hence all the surrounding units will move towards this centre till it meets with an opposing reaction to stop its movement and thereby regain the balanced state. The inward move produces the Linga state while the moving units are in the Bhava phase.

Secret Of Sankhya: Acme Of Scientific Unification.



**Suthra 46.**

Interactions in the coherent state cause 50 orders of change.

***Yesha prathyayasargo***

Axiomatically ascertained-spectrum-of- manifestation

***Viparyayaashaktithushtisidhaakya: .***

interchanging-unsynchronised-balanced-coherent-defined

***gunavaishamavimardath***

interaction due to unbalanced state of gunas

***thasya cha bhedasthu panchasat.***

Hence the varieties are fifty orders

**Meaning.** The axiomatically ascertained order of the spectrum of interchanged states due to the conditions of unbalance, non synchronisation, balance and coherent synchronisation caused by the interplay of three guna modes of interaction are 50 (order of powers).

**Explanation:** It is an extremely important theorem that identifies the incremental variations by a process of permutation and combinations , possible due to three major interactive modes of the Gunas producing 4 complementary phases of balance and synchronisation and its opposites.

Viparyaya – interactive

Ashakti – unsynchronised or weak

Thushti balanced and equalised

Siddhi coherent & synchronised

Siddhi	Thushti	Ashakti	Viparyaya	
	4+5=9	9+8+11=28		10+18=28
8	9	28	5	=50

1	3	5	7	9	=25
9	7	5	3	1	=25
10	10	10	10	10	=50

## Secret Of Sankhya: Acme Of Scientific Unification.

A cycle has 4 phases (Suthra 30) and adds sequentially to  $1+2+3+4=10$  which forms the standard count in a cycle and also gives the logarithmic base in internal changes that are deemed to take place instantly or self-similarly within the unit cycle. The log

Any rate increase in the substratum must be an incremental one. It means that the increase is over the previous state. The graphical display shows a 1 to 10 sequence in rate laid out as combinatorial state in the substratum. The white shows a count rate of 1 and next to it is red with a count of rate 2 but it has 3 components and count rate 3 as orange must have 6 components and so on . The gradient is shown in the left graph. Neither 1 nor 3 can divide into equal integers to oscillate In a stable mode but 1 can combine with 3 to form 4 which can interact as a colliding  $2 \times 2 = 4$  and separate as a sequential decay of  $2 + 2 = 4$  , thereby keeping the cycle balanced. Similarly every combination upto a cycle count of 10 is shown. It progress as 1,3,6,10 etc and the combinations progress as

$$\begin{array}{cccc}
 1+3=4 & 6+10=16 & 15+21=36 & 28+36=64 \\
 45+55=100 & & & \\
 4 (2 \times 2) & 16 (4 \times 4) & 36 (6 \times 6) & 64 \\
 (8 \times 8) & 100 (10 \times 10) & & 
 \end{array}$$

In the substratum only one side remains above the ground level vibrations rate of C and the remain below , that is within C or C cubed

An oscillating state must be able to split or divide equally if it is to remain stable. That is if the instantaneous product of colliding Thaamasic interaction is to be balanced with the expanding Satwic sequential time like reaction, then the rate of separation in both directions must be equal to half of the Thaamasic product value. By combining two

322

Secret Of Sankhya: Acme Of Scientific Unification.

adjacent states it is possible to produce divisible states that produce such synchronised combinational levels as follows and splitting it by half to keep the rate same in both axis to retain coherence and synchronisation:

$$2 + 2 = 4 \quad 8 + 8 = 16 \quad 18 + 18 = 36 \quad 32 + 32 = 64 \quad 50 + 50 = 100$$

The incremental rate of such combined sequences increase by one unit based on its own time cycle. Hence it is stable and it cannot divide in any other way.

$$2/2=1 \quad 8/4=2 \quad 18/6=3 \quad 32/8=4 \\ 50/10=5$$

The odd number gap between product of interactions can also combine as follows:

$$1 \quad 3 \quad 6 \quad 10 \quad 15 \quad 21 \quad 28 \\ 36 \quad 45 \quad 55$$

Sequential or additive

$$3 + 6 = 9 \quad 10 + 15 = 25 \quad 21 + 28 = 49 \\ 36 + 45 = 81$$

and simultaneous interaction

$$3 \times 3 = 9 \quad 5 \times 5 = 25 \quad 7 \times 7 = 49 \\ 9 \times 9 = 81$$

Since odd numbers cannot divide all these interactive combinations are transient but the following sequential or time involving Raja combinations are stable and balance the interaction and decay harmoniously.

$$1 \quad 2 \quad 3 \quad 4 \\ 5 \\ 1 + 1 = 2 \quad 3 + 3 = 6 \quad 5 + 5 = 10 \quad 7 + 7 = 14 \\ 9 + 9 = 18 \\ 323$$

## Secret Of Sankhya: Acme Of Scientific Unification.

The total of these are also 50 and shows that it can be in a balanced state because the recurring gap of 4 is harmonious as  $2 \times 2 = 2 + 2$

$$2 + 6 + 10 + 14 + 18 = 50$$

The five orders of combinational change gives 2, 8, 18, 32 and 50 in both directions and  $2 + 6 + 10 + 14 + 18 = 50$  as sequential combinations cover every unit incremental rate to provide a stable interactive group at all levels above and below the neutral level. Even though the combination process involved uneven incremental counts the ratio of the change increases only in discrete unitary steps to maintain proportionality. The incremental ratio ascends unit by unit, thereby maintaining the integer relationship necessary to hold the integer count relationship order in both the internal logarithmic (instant) and external numerical (sequential) increments. It establishes the rationale for the synchronised states that allow two or three axis to oscillate synchronously within a single unit to give it the centre of form or mass status. Further it allows two adjacent axis with same oscillatory count to remain in locked synchronous, coherent mode producing the bonding, linking or coupling effect seen as orbital capture in atomic and molecular states. When two or three axis counts are not the same the counts multiply to produce all the possible variations in interactions. If synchronised the counts are absorbed and seem to disappear but superpose along the axis as a changed Linga state (acquire mass) from the previous varying Bhava phase. A visual example would be that of two gear wheels rotating at different speeds trying to mesh but are kept apart by the teeth on one contacting in turn all the teeth on the other wheel and both wheels stay separated by a distance equal to the sum of the two radii. When the revolutions are synchronised the teeth mesh and the gear wheels move in closer to each other because each tooth occupies the gap in the other wheel, thereby producing a

324

## Secret Of Sankhya: Acme Of Scientific Unification.

reduction in the volumetric status which is the equivalent synchronous or coherent state of acquiring a mass or superpositioned wave number or increase in the field potential or orbital capture or bonding or coupling etc.

The consequence of this spectrum is that within the component of the substratum the maximum number of interactions that can be accommodated or superposed or made massive or increase the static potential by, is  $10^{50}$  counts.

The combinatorial process shown keeps any two axis synchronised with the third axis to keep the state of the ensemble in unified , coherent , selecting and with a unified centre of mass action. To maintain synchrony and coherence all interacting values must be even numbered or else timings in two axis can vary by half an integer that would not stay in static relative position with another component, in which case synchronisation, coherence and resonance is lost .

The unit increase in the substratum is within a cycle but it must be remembered that a an increase from 9 to 10 needs a cycle fraction of  $1/9$  to  $1/10$  to change one count whereas 99 to 100 requires  $1/99$  to  $1/100$  of the cycle for the same unit. The principle of division is on self similar basis. The first slope is 1 to 2 , which means the average rate of change per unit is

$$(\sqrt{1^2 + 2^2}) = \sqrt{5} / 2$$

The maximum self similar increment in rates must be based on what is available at that instant and that gives the following series:

1	2	3	4	5	6	7	8
9	10						
0 + 1 = 1	2 + 1 = 3	5 + 3 = 8		13 + 8			
= 21	34 + 21 = 55						
	1 + 1 = 2	3 + 2 = 5	8 + 5 = 13				
21 + 13 = 34							
325							

## Secret Of Sankhya: Acme Of Scientific Unification.

In order to make it scale invariant the above incremental series must be reduced to the same slope or first ratio  $\sqrt{5}/2$  which gives the final power series as follows:

The factor  $x = 1.618$

$$1 \quad x / \sqrt{5} / 2 = 2.236 = x^2 = 2.618$$

$$2 \quad x / \sqrt{5} / 2 = 4.472 = x^3 = 4.236$$

$$3 \quad x / \sqrt{5} / 2 = 6.708 = x^4 = 6.853$$

$$5 \quad x / \sqrt{5} / 2 = 11.18 = x^5 = 11.09$$

$$8 \quad x / \sqrt{5} / 2 = 18 \quad = x^6 = 18$$

$$13 \quad x / \sqrt{5} / 2 = 29 \quad = x^7 = 29$$

$$21 \quad x / \sqrt{5} / 2 = 47 \quad = x^8 = 47$$

$$34 \quad x / \sqrt{5} / 2 = 76 \quad = x^9 = 76$$

$$55 \quad x / \sqrt{5} / 2 = 123 \quad = x^{10} = 123$$

Note: The electron number periodic table follows the same combinational process 2, 8, 18, 32 and 50 along two axis but does not reach the 50<sup>th</sup>. order as the atomic density exceeds the coherent and synchronised level at the 42<sup>nd</sup>. count and therefore combinations beyond 84 along two axis become unstable and start to decay and becomes radioactive. Since the atomic periodic table is built by combining above the base or ground level of C cubed , the two sides of the interaction are added on the same side above the ground level like (the first 2 is below ground level)

$$2 + 8 = 10 + 8 = 18 + 18 = 36 + 18 = 54 + 32 = 86 + 32 = 118 + 50 = 168 + 50 = 218.$$

All these values in the periodic table are above the substratum.

Secret Of Sankhya: Acme Of Scientific Unification.





**Suthra 47.**

Balanced , synchronised and its reversed variation sequence of interactions.

***pancha viparyayabheda***

Five-orders-of-interchanging states

***Bhavantyaashaktischakaranavaikalyath.***

synchronous and non synchronised interaction

***ashtavimsathibhedatusthirnavadhaashtadha***

28 orders of change balanced 9<sup>th</sup>.order 8<sup>th</sup>. order

***siddhi***

coherent state.

**Meaning:** A sequence of 5 orders (power index) of change is created by the three varying states of interaction like non-synchronous, interactive change and synchronous. Weak and unsynchronised states have 28 orders while the balanced phase has 9 orders and the perfectly synchronised state has 8 orders of sequentially variable levels.

Explanation:

Thaama	Li/Bh	Raja	Ab/Ah	Satwa	
9	0.5+0.5	8	2+1=3	8+3=11	28
9	.5+.5=-1	8	-2-1=-3	8-3=5	22
18	0	16	0	16	50

The 4 cycle phase has a maximum of 10 counts and assuming that it is purely internal the Thaama product of  $10 \times 10 = 100$  is split equally as a sequential Sathwa expansion of  $50 + 50 = 100$  to maintain a balance. Hence 50 per direction is a limit in a balanced state. The 5 variations are shown within the count of 50. Each sequence has its own internally coherent rate.

The five orders of variation, both in the non synchronised and synchronised states, increasing in steps of one count order or 10 counts, are as follows

2+2=4	8+8=16	18+18=36	32+32=64	50+50=100
-------	--------	----------	----------	-----------

Secret Of Sankhya: Acme Of Scientific Unification.

$2/2=1$	$8/4=2$	$18/6=3$	$32/8=4$	$50/10=5$
$2 \times 2=4$	$4 \times 4=16$	$6 \times 6=36$	$8 \times 8=64$	$10 \times 10=1-00$

The change from 2 to 8 , 8 to 18, 18 to 32 and 32 to 50 is by the addition of two odd or indivisible rates combining sequentially or staying in adjacent synchronous states . The odd states or confined or contained by even rates to make it coherent and synchronised. The following states form the atomic spectra along one axis and when synchronised with another axis the counts increase by the same number or its paired counterpart.

$2+3+3=8$	$8+5+5=18$	$18+7+7=32$	$32 + 9+9 = 50$
-----------	------------	-------------	-----------------

Siddhi states or coherent and synchronised phases. Any count ratio of 4 has a unique balanced state because  $2 \times 2 = 2 + 2$  and can never become unsynchronised or incoherent or unbalanced and therefore can never be detected or recorded as an interaction and this count structure will always be hidden as a Linga or mass phase in a permanent state. Therefore the 8 and 32 count step will remain as perfect coherent or synchronised siddhi states:

Combinations  $32 + 32 = 64 = 8 \times 8 = (2 \times 4) + (2 \times 4)$ ,  
 $32/8 = 4$

But it can combine with adjacent states to produce variations.

Tusti states or balanced mid order states. The 3<sup>rd</sup>. order 18 can divide into 9+9 as intermediate states. 9 is formed by 3 x 3 interactive states with its own Linga or centre of mass capabilities as 3 is the order of the damping force .

The Asakti states or weak or unsynchronised states formed by combination are :

$5 + 5 = 10$	$8 + 10 = 18$	$10 + 18 = 28$
--------------	---------------	----------------

Since 2 and 8 are synchronised states it can become unsynchronised by combining with the 3<sup>rd</sup> state of 18 and the total combination is 28 orders.

Secret Of Sankhya: Acme Of Scientific Unification.



**Suthra 48.**

Order of compression increase when one, two and three axis synchronise.

***bhedasthaamasoashtavidho***

varieties-compressively- 8<sup>th</sup>. order

***mohasya cha dasavidho mahamoha:***

superpositioned and 10<sup>th</sup>. order deeply nested

***tamisroashtadashadaathabhavathyandhathaamishrah***

coherence 18<sup>th</sup>. order of charge forms the darkest densest level.

**Meaning:** Interactive changes in the compressive thaamasic state proceed on the basis of 8 orders of change. along one axis and increases by the same order when it synchronises with another axis at a deeper level. at the next intermediate level it increases by 10 orders and at the final core level it increases by 18 and by another 18 at deepest core level synchronisation. that is  $8 + 8$  , followed by  $(5+5) =10$  in each axis and finally  $(8+10) 18 +18$  . It is a combinatorial process of incremental rates that can synchronise and remain in balance only as even numbered levels.

interactive changes in the compressive thaamasic state proceed on the basis of 8 orders of change along one axis and increases by the same order when it synchronises with another axis at a deeper level. at the next intermediate level it increases by 10 orders and at the final core level it increases by the sum of  $10+18$  or by another 18 at deepest core level of superpositioned synchronisation.

**suthra 49.**

the 11 & 17 orders of the weak and balanced groups.

***ekadashaindrayavadha saha***

eleven –orders of expansion capable

***bhuddivadhairashaktiruddishta***

coherent-action-obstruction-weak-named

***sapthadhasavadha bhudderviparyayath***

seventeen orders coherent-non-synchronisation

***thusthisiddhinam.***

balanced-coherent phases

**Meaning:** eleven orders of expansive interactions cover the observable range out of the previous 28 orders mentioned before. The balance of 17 orders consists of the balanced and coherent states and the radiant states. With the 5 orders of radiant state it forms 22 orders. The 17 orders form the common potential to both phases.

**Explanantion:**The 50 orders comprise two sections of self similar groups as follows :

$$((25+1+2)=28) + ((25-1-2)= 22) = 50 = (28 -3 =) 25 + 25 (= 22 + 3 )$$

$$28 = 11=( 8 + 3) + 17( = 9 + 8) : 22 = 5(= 8 - 3 ) +17 (= 9 + 8 )$$

**Suthra 50.**

50. Nuclear balancing paramaeters

***adhyaathmikachatahra:***

the internal nuclear field fourth power

***prakrityupaadaanakaalabhaagyaakya:***

Self-action-material-cause-time-destiny-defined

***bahya visayoparamath pancha***

external objects fundamental fifth power

***nava thushtayo:bhihitha***

nine balanced-both-equalised

**Meaning:** The interaction inside the nuclear state can be labelled as fourth power, initiating cause of action and responsive self reaction , the time period of the reaction and the destined potential available for the reaction. Externally detectable fundamental activity is categorised as the fifth power and when these two act together synchronously it is the ninth power.

**Explanation:** The interactions remain internal because it is balanced. The fourth power of internal instantaneous interactions are balanced if the four phases of internal balance exist. These are perpetual oscillatory state, its reaction, duration and environment.

**Suthra 51.**

51. Colliding interaction cause of vibrations.

***Uha: shabdhoadhyayanam***

knowledge gained cause of vibrations through research

***dhukhavighathasthrayah suhrthaprapthih***

stress colliding tripleacting intensive-superpositioned

***dhaanam cha siddhaya'ashto siddhey:***

divergent also synchronised 8<sup>th</sup>. order coherence

***purvon'gkushasthrividhah.***

previously controlled state third power

**Meaning:** Knowledge gained through research on vibratory or oscillatory stress caused by colliding interactions follow three step action (of compression – shuttling- expansion –guna mode) leading to intensive superpositioned, divergent, or synchronised state, raised to the eighth power coherent mode. The original state prior to the interaction has been established to be in a controlled, compressed, cubic, volumetric state, raised to the third power.

**Explanation:** The components of the substratum are in a dynamic and synchronised state corresponding to a volumetric or cubic representation and follows a third order damping control or reaction, proved and established in the derivation of rules controlling the triple acting guna interactions. The normal dynamic state is maintained by resonant interactions wherein the three phases of thaama compression, rajah shuttling interaction and consequential reactive sathwa expansion that equalises according to swabhava or self similar rules. However when a collision occurs the intensity causes the vibrations or oscillations to aggregate, collect, pile-up or superpose on the component such that the density, mass or inertia increases to eight

336



## Secret Of Sankhya: Acme Of Scientific Unification.

times or powers (instantaneously). The proof of this behaviour is established by analytical and mathematical logic as follows: at the instant of collision the oscillatory counts of the two components combine to form a THAAMASIC increase proportionally to two units. The increment must take place along all three axis to maintain the synchronised and centred state so the count value rises to  $2^3 = 8$  within the instant duration of the collision (See note 1). The corresponding RAJASIC interaction must equal 8 counts in the normal sequential spatial shuttling form in which it normally oscillates. The SATWIC expansive reaction must account for the 8 units by equalising in an expansive mode. Since only two components were involved in the colliding interaction the reactive values must be generated only by these same two units as an expanding displacement . Had there been eight unit components involved in the collision the equalisation could have been possible within the unitary cycle by all the 8 components absorbing the 8 counts. Therefore the two unit components must now equalise in eight sequential steps or stages or the duration must equal eight sequential steps to absorb the increased counts. Subtracting the normal unit displacement in a unitary cycle there are seven additional expanding vibrations or oscillations superposed or accumulated on the component. Therefore the Raja interactive shuttling duration shows seven distinct phases of the oscillations that are superposed in a sequence of seven additional wavelengths in a cycle. This state continues because the next cycle adds a similar count value so that the counts increase logarithmically to the 8<sup>th</sup>. power in a cycle . As a cycle contains 10 units as a count duration, (Suthra 30) the 8<sup>th</sup> power is based on 10. So the consistent , constant, resonant, synchronised state of a cycle must contain  $10^8$  counts increment or additional interactive displacements that are equally subdivided into the expansive RAJASIC – SATWIC cycle. Summarising, an

## Secret Of Sankhya: Acme Of Scientific Unification.

intense colliding interaction value rises to two units that is then translated into cube of two displacements that superpose and the expansive reaction equalises the instantaneous rise in cycle time value of 8 in sequential displacement of 8 cycles and subtracting the normal, usual unit value there exist seven sequential expanding cycles for each intensive collision. If the 3 axis counts are synchronised then the count remains at  $10^8$  and the spherical boundary remains undisturbed . If the 3 axis loose the synchrony the sphericallity is lost and the count rises to a maximum of  $10^{25}$  . The observed spectrum of seven colours in light created by an accelerated photon as set , or the seven sound frequencies created by an impact in air are the consequences of the above explanation. One must note that the substratum is in constant dynamic , selfsimilar interaction but light is produced only when it is in an accelerative or unbalanced and therefore non-spherical interaction, because had it been otherwise light would have been spontaneously emitted from the substratum and spherical photons with helicity zero would have been detected. The components of the substratum are oscillating continuously at a self similar rate of 296500000 cyclic interactions consistent with a stable oscillatory cycle due to a1 to 2 difference in timing between the axis. Similarly the field of air molecules are vibrating at the same proportionate self similar rate of 256 interactions for a unitary cycle, because the air field is not a free one and synchrony along two axis is forced . The statement that there are so many interactions in a cycle means that not a single interaction is simultaneous with another during that cycle. Both in light and sound and in every spherical harmonic oscillator there are seven incremental levels of changing values before it repeats. This situation is true only if the field functions in the normal SWABHAVA state of freedom from external influences. And above all this self similar behaviour is

Secret Of Sankhya: Acme Of Scientific Unification.

possible in a substratum of equalised, similar, identical and compacted plenum of components.

Note 1. Using momentum conservation (though not applicable) principle and using a unit mass then the displacement on colliding will be half the diameter of the component and the volume will be proportional to  $\frac{1}{2}$  cubed and density will rise to 2 cubed within the impact duration and this must be dissipated by a linear movement of both units away from the centre. If both units move at the same speed in opposite directions the centre of collision remains stationery. If one remains stationery the other moves away at  $10^8$  .

Note 2. The same behaviour takes place when measuring waveforms on an oscilloscope. If the timing between the vertical and horizontal axis is identical then a single diagonal line or a circle would be visible. If the timing between the two axis is made different then numerous waveforms in continuous motion would be visible. A triggering pulse is needed to make the waveforms superimpose one train of waveforms on the next train to make them stay stationery .These patterns are called Lissajou figures and are used to study the state of synchrony between two axis.

In an odd count interaction the only possible way of synchronising is by combining with the next incremented count rate, which provide the following sequence of numbers by of previous to present and can be expressed as a formula where  $n =$  previous number.

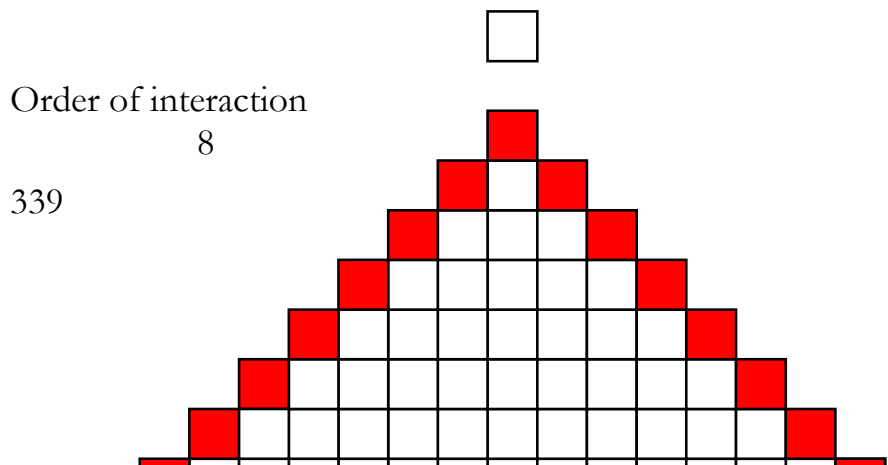

## Secret Of Sankhya: Acme Of Scientific Unification.

7  
6  
5  
4  
3  
2  
1

Spread of interaction 7 6 5 4 3 2 1 0 1 2 3 4 5  
6 7

### Fig. Incremental States By Combinatorial Process.

The cycle has 10 counts and in 8 cycles 80 counts reside in the same location if no net displacement is there. The 70 counts occupy adjacent levels and indicate the superpositioning level. The 70 counts are to be accounted for because the 8<sup>th</sup>. is the original state and can never get lost. If the displacement is equal on both sides then the domain of activity remains centered else it moves by the net difference in the direction of retarded or negative or slower activity level. The observed spectrum of seven colours in light created by an accelerated photon, or the seven sound frequencies created by an impact in air or the consequences of the above explanation. One must note that the substratum is in constant dynamic, self-similar interaction but light is produced only when it is a colliding or accelerative or unbalanced interaction, because had it been otherwise light would have been spontaneously emitted from the substratum. The components of the substratum is oscillating continuously at a rate of 296500000 interactions in a cycle but reacts only if there is an unbalance. Similarly the field of air molecules are vibrating at the same proportionate self-similar rate but at a rate of 256 interactions for unitary cycle. The statement that there are so many interactions in a cycle means that not a single interaction is of the same value during that cycle. Both in light and sound and in every spherical

340

Secret Of Sankhya: Acme Of Scientific Unification.

harmonic oscillator there are seven incremental levels of changing values before it repeats. This situation is true only if the field functions in the normal SWABHAVA state of freedom from external influences.

### Suthra 52.

52. The polarisation of phenomenon into coherent potential (mass) and kinetic potential (charge) modes.

***na vina bhavairlingham***

not without kinetic-phase-coherent state

***na vina lingena bhavanirvrithi:***

not without coherence potential phase the kinetic state  
vortex

***linghaakhyo bhavaakhyatasmadhvidha:***

mass-defined defined charge hence polarisation

***pravartate sargah.***

Initiates phenomenon

**Meaning:** Neither can a characteristic potential source exist without a kinetic phase nor can a potential phase

## Secret Of Sankhya: Acme Of Scientific Unification.

without a kinetic mode. A vorticular particle existed due to a potential source. The potential is classified as mass and the kinetic phase as charge from which dual combination all phenomenon is initiated and maintained by a dual mode of polarisation.

**Explanation:** This shows the interdependence of static and dynamic potential in the substratum. In the coherent and symmetric state there is no preferred or prevalent or predominant orientation and as there is no physical movement of components the cause and effect determines the potential and kinetic phases. The potential phase change induces balancing procedures which is the kinetic phase and when it exceeds the self-similar rate of balance then it becomes externalised and displays radiant qualities.

**Suthra 53.**

53. Guna classification.

*ashtam vikalpam daivam*

eightfold variations natural phenomenon

*thairyagyonam panchada bhavathi*

the sequential five modes

*manushyam tvaikavidham*

coherent single class

*samasathoyam tridha sarga.*

succintly restrain threeways manifest phenomeno.

**Meaning:** Natural or inorganic or matter oriented phenomenon is the result of 8 orders of variations and the sequential are five orfdrs. The self sustaining order is from a single variant, these three classes succintly control the complete spectrum of phenomenon.

**Explanation:** Natural phenomenon operates as a spectrum of 8 levels. As the fundamental dynamic state is an oscillatory activity the very first state must axiomatically cover the increment from level one to two. That the expansive state of the oscillation will rise as  $2^3 = 8$ . Hence, as these are distinct phases of activity levels it presents phenomenon at 8 stages at the fundamental level. From these 8 expansive stages , 3 levels by combining form coherent states, which again become the building blocks for 5 remaining states. If the 8 states are termed as a horizontal or sequential process the combination of three plus the remaining five are transition states using the 3 synchronised levels as unitary base states for the five. Then finally when all 7 levels combine into a single coherent form, within the spectrum of 8, it is a free and mobile state totally dependant on itself. It marls the initiating phase of a unit of mobile or free phenomenon.

## Secret Of Sankhya: Acme Of Scientific Unification.

The seven levels form a spectrum like light, sound etc. Each has a distinctive characteristic of identification. When all these 7 are combined into a coherent ensemble and radiated it forms a vrithi. For example light has photons, sound has phonons, and at the subatomic, atomic and molecular levels, the gluons, mesons and bosons and so on. At the Galaxy level, rings of stellar bodies form the spectrum and at the stellar level planetary bodies contribute to these states. The atomic periodic table represents agglomerate levels of groups with distinctive characteristics. These combinations continue at nested levels of fundamental groups. Like the chemical and mineral groups on earth are sub-groups of atomic/molecular combinations. Further the botanical and biological species are derivatives of the previous groups. The Sutra lays out the principle through an allegorical comparison to species on earth.



**Suthra 54.**

54. The distribution of Guna interactive states.

***urdhvam satva vishalastamovishalasva***

higher orders expansive predominantly denser region

***moolatah sarga.***

basic order of manifestation

***madhye rajovishalo brahmaadistambapariyantham.***

The mid resonant order covers brahma to grass ultimately..

**Meaning:** Ascending order of outward manifestation is predominantly sathvic and the descending inward mode of creation is predominantly thaamasic and the intermediate range is predominantly rajasic and it is consistantly so right from the starting dynamic creative field of brahma to a blade of grass and final state of manifestation.

**Explanation:** The single coherent state polarises into the three phases of expansive, dense and the intermediate phase. The axiomatic self similar law of distribution of phases through suerposition of intreractive stresses must follow the single guna form of polarisation. That is the denser region can form only by borrowing from another phase which automatically becomes the lighter one. Naturally the denser region will have a higher interactive count and so becomes the fundamental foundation for all phenomena. The transition phase in the middle must have a ratio that reflects both states or it becomes the halfway state of change. The distribution following guna classifications then have a numerical distribution of two states as  $x + x^2 = 1$  and the 3 phase distribution as  $x^2 + 2x^3 + x^4 = 1$ . This Sutra refers to latter numerical expression which reflects the polarised state of the substratum in the mode of manifestation. The former reflects the quiescent state of unmanifest balance.

**Suthra 55.**

55. Stress in three modes follows self similar laws in the dynamic substratum.

***thathra jaramaranakritam dhukham***

therefore growth-to-decay-activity stress

***prapnothi chetanah purushah.***

attainment dynamic nucleus

***lingasya vini vritheh.***

superpositioning minimised vortex

***tasmad dhukham svabhavena.***

thus stress self similar

**Meaning:** Therefore the process of decay and destruction introduces interactive stresses that create the dynamic state of the the purusha and on its absorption of the vorticular interactive activity by the nuclear core the process of superpositioning continues until the interactions are minimised and a coherent self-similar state is established.

Mathematical:

$$1 / x = 1 + x$$

Explanation: Interactive states create stress by colliding and it decays by expanding and transmigrating to other states where it gets absorbed or initiates action. Compressive stress will expand and its reaction will create a reversal of action. The process when balanced provides the motivating cause for continuing activity which ultimately decays back into the field of space.

Secret Of Sankhya: Acme Of Scientific Unification.

**Suthra 56.**

56. Manifestation is the result of interactions to maintain the balance between nucleus and boundary.

*ithyesha prakrithikritho*

thus-axiomatic oscillatory activity interactions

*mahadhadhivisheshaabhuthapariantha:*

intense force source static matter to the very end.

*prathipurushavimokshaartha*

towards nucleus isolating potential

*svartha eva parartha arambha:*

self acting potential other reactive potential initiates.

**Meaning:** In this way interactive oscillatory activity is initiated and perpetuated from the intense fundamental activity at the source to the final coherent superposed massive state at the isolated nuclear boundary where the self potential balances with the reactive potential from the start .

Explanation: The mathematical logic is rigorous and is shown in the explanatory comments of the last few Sutras. The interaction are between the core and boundary. The stresses are intense towards the core and accelerative towards the boundary. Compression rebounds initiating reaction and expansion slows down when the potential minimises. This exchange maintains the oscillatory state.

Secret Of Sankhya: Acme Of Scientific Unification.

**Suthra 57.**

Attainment of a coherent superposed state initiates oscillatory state.

*Vatsavivridhwinimitham ksirasya*  
Calf- growth without apparent cause milk  
*yatha pravritter ajnasya*  
like commencement in all innocence  
*purusha vimochanaksha nimittam*  
nucleus goal of freedom without apparent cause  
*thatha pravritti pradhanasya*  
of commencement fundamental oscillatory activity.

**Meaning:** The growth of a calf is due to both , milk as its food and its commencement without any apparent cause or specific instruction ; in a similar way the goal of the nuclear state to attain a state of restful balance, isolation or freedom from action-potential, is both the cause of initiating and maintaining a fundamental oscillatory state of continuous activity of the substratum.

**Explanation:** The allegorical statement highlights the silent mode by which coherent states are created . The synchronisation of oscillations within a finite interval causes increase of mass because two activities have combined to form a single action.

Secret Of Sankhya: Acme Of Scientific Unification.

**Suthra 58.**

58. The Unmanifest state maintains the potential to act.

***authsukyanivarthartham***

anxiety - covering-purpose

***yatha kriyasu pravarthathe loka:***

just as activity initiated by people

***purushasya vimokshartham***

for the nucleus purpose of releasing

***pravarthathe tatvad avyaktam.***

initiate

similarly unmanifest state

**Meaning:** Just as people are motivated to initiate action to reduce their anxiety; similarly the unmanifest state maintains the purusha in an isolated state free of stresses by absorbing the activity of the continuous static and kinetic balancing interactions

**Explanation:** The nucleus is in a state of relative rest because it is isolated from the potential to act or vibrate. Unless there is a an inert or passive base to absorb the interactions or provide a screen from constant interchange of static and kinetic potentials to maintain a balance, the nuclear state of coherence can not be maintained. Therefore the unmanifest or inactive state is a necessary condition and allegorical example is used to to highlight this factor by comparing the silent and hidden human potential quality of “anxiety” as a latent motivation that maintains activity, similar to the hidden and undetectable Avyaktha state of the substratum. The unmanifest state is devoid of detectable level of activity and therefore forms the activity absorbing base, groundlevel or sink.

The process of absorbing activity counts has two aspects. When absorbed it can increase either the coherent count or its activity count. If the process of absorption equalises along two axis its state changes from Sathwa to Raja state.

Secret Of Sankhya: Acme Of Scientific Unification.

On equalising along three axis the Raja shifts to the  
Thaama state. Maths?



**Suthra 59.**

59. Forming of nucleus due to reduction of potential difference.

***rangasya dharshayithva nivarthathe***

on stage desire to be seen ceases

***narthaki yatha nrithyath.***

dancer by dancing

***purushasya thathaatmanam***

nuclear state thus self energy

***prakashya vi nivartate prakrithi***

by radiating diminishing oscillatory state

**Meaning:** Just as the external exhibition of a dancer's performance reduces the urge to continue performance because it satisfies his desires; similarly the outward spreading of internally motivated self energy diminishes its potential to radiate and thereby reaches an interactive state of balance in an oscillatory state.

**Explanation:** The alegorical picture shows that activity radiates vrithis of diminishing numbers to emphasise that the potential is reduced as radiation takes place and to introduce the concept that the vrithi or photon must decay eventually. Radiation is potential dependent.

Equation S.59. All the stable states radiate reducing number of moolaprakrithis till the Vrithi Ne state.

$\frac{Kx}{my} = 6.80480571 \cdot 10^{50}$	$\frac{Mps}{my} = 1.6388973 \cdot 10^{43}$
$\frac{PM}{my} = 1.24527591 \cdot 10^{24}$	$\frac{Me}{my} = 6.77532106 \cdot 10^{20}$
$\frac{Ne}{my} = 7.0865616 \cdot 10^{16}$	

Secret Of Sankhya: Acme Of Scientific Unification.

Equation S.59.A. The radiation of a Vrithi of photon takes place when 7 Ne states are simultaneously accelerated. The Plancks constant as the value of a quantum of radiation in physics shown as h is equal to 7 Ne or the spectrum of energy around the nucleon.

$$\frac{7 \cdot \text{Ne}}{\text{my}} = 4.96059312 \cdot 10^{17} \quad \frac{h}{\text{my}} = 4.92778547 \cdot 10^{17}$$

Equation S59. B. The equivalent states in physics is shown in units of electron volts and it is interesting to note that the hydrogen spectrum of 13.6 electron volts (ev) is actually the first expansion boundary at  $k-1=0.259921$ . The Ne or neutrino of 7 levels has a value of 53.45 ev .

$$\begin{aligned} \text{Ne} \cdot Z &= 53.45176528 & 7 \cdot \text{Ne} \cdot Z &= 374.16235694 \\ \text{Ne} \cdot (k - 1) \cdot Z &= 13.89323895 \end{aligned}$$

**Suthra 60.**

60. Cause of interactive oscillations

***nanavidhairupayorupakaarinya:***

various-controls-corective-supporting

***anupakaariny pumsa:***

passive                      nucleous

***gunavathyaagunasya***

with guna and its converse qualities

***sathasthasyarthamaparthakam                      charathi***

dynamic non-dynamic-potential-potential-less    oscillates

**Meaning:** Variety of controls, correcting and supporting interactions are provided by the active prakrithi state to keep passive nuclear state with and without the interactive guna qualities in an oscillatory mode.

**Explanation:** The coherent nuclear state of oscillatory balance is constantly controlled by a variety of opposing states of interactions that reflects the three guna states in all its combinations. It could support or oppose to keep the oscillatory state in dynamic balance. The essential state of a balanced oscillatory activity is one of self-similarity in a simultaneous mode. As an example a bow could be seen as a balanced state of stresses. The arch is under two modes of stress. Compression in the inner side and tension on the outer side while the string is in a resonant state of balance. If the string is pulled the arch of the bow is bent more which consequently increases both the compressive and tensile stresses . On release of string the bow snaps back into its former state. The action of the bow highlights the concept of using simultaneous states of accumulated stress to release it instantly to gain velocity in the arrow. Again the bow can pulled slowly and snap

355

Secret Of Sankhya: Acme Of Scientific Unification.

released. In the steady state it is in a resonant state of constant balance to correct the fine oscillations of the string.

Two major constraints are introduced here. In any field of components, stress is caused by polarising its normal inactive state. If the polarised state can be contained perpetually only then can an oscillatory state exist. Its change initiates reactions as a consequence. Hence the dynamism in space can be defined by these concepts. Perpetual oscillation must be derived by transcendental numbers which form infinite series. Generalising the Guna relationship, Thaamasic states = Rajasic x Sathvic states. Elaborating coherence= Resonance x radiance. Putting into three dimensional states Volumetric = Area into Length. The oscillatory aspect is represented as Axis<sup>3</sup> = Axis<sup>2</sup> x Axis.

Equation S.60. The Thaamasic state is balanced as follows:

$$\frac{\text{Thaamasic}}{\text{(Sathvic)}} = 1 = \text{Coherence} = 2^3 = 8$$

$$\left[ \frac{\text{Thaamasic}}{\text{(Sathvic)}} \leq 1 \right] = \text{Compressive} = \sum_j \left( \frac{1}{2^3} \right)^j = \frac{1}{7}$$

$$\left[ \frac{\text{Thaamasic}}{\text{(Sathvic)}} \geq 1 \right] = \text{Rajasic} = \text{res\_P} = \sum_j \left( \frac{2}{10^2} \right)^j + 1 = 1.02040816$$

$$\left[ \frac{\text{Thaamasic}}{\text{(Rajasic)}} \geq 1 \right] = \text{(Sathvic)} = \text{Expansive} = 10^{\sum_j x^j} = 41.4986519$$

Secret Of Sankhya: Acme Of Scientific Unification.

Equation S.60 A. The fundamental oscillatory state is built up by polarising the two adjacent components through transcendental series to maintain the oscillatory state perpetually. The Purusha value Kx remains perpetual through axiomatic interactions in a self similar mode.

$$\left( \frac{\text{Thaamasic}}{\text{Rajasic}} \leq 1 \right) = \text{Sathvic} = \text{res\_N} = \frac{1}{2^3} = 0.79370053$$

$$\text{PURUSHA} = \frac{\text{Compressive} \cdot \text{Expansive}}{\text{res\_P} \cdot \text{res\_N} \cdot \text{Coherence}} = K_x = 0.91498794$$

$$\frac{\left[ \sum_j \left( \frac{1}{2^3} \right)^j \right] \cdot \left( \sum_j x^j \right)}{\left[ \sum_j \left( \frac{2}{10^2} \right)^j + 1 \right] \cdot 2^3 \cdot \frac{1}{2^3}} = 0.91498794$$

**Suthra 61.**

The oscillatory displacement at the point of balance is very attenuated.

***prakritheh : sukumaatharam***  
oscillatory displacements very fine-move-angular  
***na kimchidhasthithi***  
almost doubtful (its) existence  
***mey matirbhavathy***  
interactiv information existence  
***ya drishtaasmitha punarna***  
obtain observable self-potential not again  
***darshanamupaiti purushasya***  
ability to be observable -of nuclear region

**Meaning:** At the nuclear boundary the oscillatory displacements reduce to a minute angular oscillatory movement that its very existence seems doubtful. The consequent reduction in the interactive self potential does not ever allow it to radiate detectable information on the state of interaction of the nuclear region.

**Explanation:** Perfect and eternal balance is maintained in the Substratum that cannot be observed as no parameters are radiated. If it radiates the balance is upset or if its balance is upset only then it radiates. There is no translational or velocity type of movement in the Substratum. The balance is maintained by a phase or angular change in the coherent relationship. Hence nothing moves.

The concept of oscillatory or vibratory count disappearing by merging with one another is a difficult process to understand. The oscillatory rate along any two axis can be identical or even if the rate is same it can start and end at different times. If there are 10 vibrations per cycle along one axis and the other too has the same rate but different timing or phasing then the count would be  $10 \times 10 = 100$ .

Secret Of Sankhya: Acme Of Scientific Unification.

But if oscillations start and finish in step the count detected at the boundary will be only 10 in a cycle because two counts are acting in step. If ten people clap ten times in second in a random order where no clap synchronises with another then a 100 claps would be heard in that time period. But if all ten people synchronise and clap together in a stepwise fashion then only 10 claps would be heard in a second but each clap (of ten people) would sound louder.

Equation S.61. Even though an interaction follows a straight line path from the moment the interaction is completed, the reason why it seems to follow a circular route is due to a difference in rate or timing of subsequent interactions.

$$i := 0..100 \quad A_0 := \frac{x}{2} \quad A_{i+1} := \frac{\sqrt{\left[1 - \sqrt{1 - (A_i)^2}\right]^2 + (A_i)^2}}{2}$$

n := 1..4	$2^n \cdot A_n \cdot 10$
	3.128689300804619
	3.138363829113799
	3.14078526072549
	3.141390793700529

The interactions following self similar proportionality approximately equal the ratio  $\pi$  in 4 count rates and continue to match it in infinite count rates as it is a transcendental number. But the difference between each sequential increase has relevance.

When the difference between two successive steps is less than the minimum interval between the maximum rate of oscillations, then two successive oscillations would be counted as one or as occurring simultaneously. The ability to discriminate the fine time cycle difference is lost and the

Secret Of Sankhya: Acme Of Scientific Unification.

counts rate gets reduced. The maximum rate of oscillation is limited by self similar ratio and the value of  $1/c^{1+x}$  and two counts merge into one. It depicts a sharp square wave timing when the maximum and minum rates occur at the same instant.

Equation S.61.A. It shows the ratio at which a count merges and semms to dissappear. The effect is to reduce the count rate at this boundary and being lower higher count rates drift toards it. This action increases the vibratory stress in it and results in increase in mass or inertia and delays the reaction.

$n := 20..21 \quad \sqrt{(A_{n+1} \cdot 2)^2 - (A_n)^2} - \frac{1}{c^{1+x}}$
$2.549963228294706 \cdot 10^{-14}$
$-8.344583610083326 \cdot 10^{-15}$

The transition from single vibration to a merged or coupled vibration at 20 to 21 count rates is clearly show above. This count rate corresponds to a rate at which a Mahadvikrithi is formed is a clue as to why Me is exposed as a detectable and an ensemble with mass is detected. If that merged count is to be realeased the count rate must be increased to above 21 so the time interval is reduced to allow the merged count to be rekeased to act freely. But this point being a coherent or simultaneous state , a whole ensemble of vibrations would be released at once. The energy released would seem to be more but conservation law is not violated because the work done in synchronising over a period of time is now equated to releasing a whole ensemble instantly. The impulse momentum equation would show its balanced state.

Equation, S.61 B. The balanced nuclear state absorbs one Vikrithi Ne in which the angular displacements in both the coherent and synchronous state are absorbed. To release 360



Secret Of Sankhya: Acme Of Scientific Unification.

aVrithi or photon 7 Ne units must be released simultaneously. But that is not possible in the values shown below. Hence nothing would be released after attaining balance by absorption unless triggered by an unbalancing interaction of 7 Ne or more.

$$\left[ \frac{PM \cdot Px}{\left( \frac{7}{2 \cdot \pi} \right)^2 \cdot Ne \cdot c} \right] = 1$$

**Suthra 62.**

62. Interactions are cause of manifestation as a holographic phenomenon.

*thasmanbadhyate napi muchyathe*  
therefore-not-bound nor even released  
*napi samsrathi kaschith.*  
nor even transmigrated neither  
*samsrathi badyathe muchyathe cha*  
transmigrated bound released only  
*nanaashraya prakrithi*  
never resting oscillations

**Meaning:** Therefore nothing is bound, released or translocated. Only the oscillatory wave forms of interactions is bound or superposed by synchronisation, released by desynchronisation and transferred by transmigration due to unequal displacements and this dynamic state continues endlessly.

**Explanation:** Therefore the concept of a particle concept of a particulate form is motion is an illusion. What moves are the stresses caused by the interactions. These stresses move as collective ensembles periodically. Hence the concept of particles bound by a force being released by another force is to be revised and gain the correct understanding that what really transmigrates is a vibratory form of waves caused by the interaction between two undetectable objects in the substratum of space. This state can only be described appropriately by the term hologram. The vibrating or oscillating state is defined by the prakrithi value and the summation of all such states in one coherent ensemble that resembles a passive or static ensemble is the Purusha value. The never resting oscillations are epitomised by an axiomatic state defined as  $R_s = 1.020408163265$ .

Secret Of Sankhya: Acme Of Scientific Unification.

An important conclusion comes out of this concept. No object can move in a plenitude of the same. The field of space comprising components that provide the foundation for an interaction cannot move. It can attempt to move but being confined it can only cause a stress by impacting with others. The stresses so created can transmigrate across components in a sequential manner within the cyclic period of an interaction, thus depicting three-dimensional or cubic waveforms. If the waveforms of stress are close and superposed a continuum of stress is created in the field of components thus creating the illusion of a solid framework in motion, from which the concept of particles in motion has arisen.

Equation S.62. The transcendental ratios for continued resonance in both compressive and expansive modes

$$\sum_j \left(\frac{1}{2^3}\right)^j = 0.14285714 \quad \sum_j \left(\frac{2}{100}\right)^j + 1 = 1.02040816$$

Equation S.62 A. Both Purusha Kx and Mahadprakrithi Mps states are equated to perpetual resonance rs and that is a positive indication that there is no force in any form is required to maintain the dynamic state, endlessly.

$$\frac{1}{10^x \cdot k} \cdot \left[ \sum_j \left(\frac{1}{2^3}\right)^j \right] = 1.02040816 \quad \frac{Mps \cdot c}{Kx} \cdot \left[ \sum_j \left(\frac{1}{2^3}\right)^j \right] = 1.02040816$$

Equation S.62 B. The Prakrithi sapha PM and Vikrithi sapha Ne also remain in perpetual balance in the same mode. It is a critical state of balance as Ne is harmonic state and transmigration is at the slightest unbalance is indicated but despite that at the balanced state it has a perpetual dynamism.

$$\frac{\frac{1}{10^x \cdot k}}{8 \cdot 7 \cdot PM \cdot c^3 \cdot Px} = 1.02040816 \quad \frac{\frac{1}{10^x \cdot k}}{8 \cdot 7 \cdot Ne \cdot c^4} \cdot \left(\frac{2 \cdot \pi}{7}\right)^2 = 1.02040816$$

Equation S.62 C. The Mahadvikrithi Me being a reactive state to the Mahadpakrithi Mps, has qn unstable position. While the Me state must exist always because Mps is a perpetually interactive process. Me resonates at the PM interface to remain in balance and that shift into the first state. Hence to maintain

$$\frac{\frac{1}{10^x \cdot k}}{8 \cdot 7 \cdot Me \cdot \left(\frac{7}{k-1}\right)^2 \cdot \left(\frac{1}{2^n \cdot A_n \cdot 2}\right)^2 \cdot c^3 \cdot Px} = 1.02031187$$

Equation S.62 D. The Boundary of the Universe at a radial distance of RU at which distance the Vrithi or photon decays back into the substratum and is absorbed, maintaining the Abhaavath state necessary for a perpetual dynamism. The state of resonance is maintained but the same degree of translocation as the Me, is also reflected at this position, which indicates a transmigratory state of stress due to absorption of decaying photons.

$$\left[ \frac{MU \cdot c^6}{10^x \cdot k} \cdot 7 \cdot 8 \cdot \left[ \frac{Lp}{(x+x)^{-2}} \right]^3 \right]^{-1} = 1.02035695$$

The conclusion from this Sutra is that there are no such things as particles but only oscillatory ensembles ranging from the Purusha state to the moolaprakrithi and its aggregates leading to a Galaxy. Because the Vrithi or

Secret Of Sankhya: Acme Of Scientific Unification.

photon decays at RU every observer will see the same depth or spherical volume of his Universe from his location. Manifestation is a conservative and democratic process at every level.

**Suthra 63.**

Interaction.

***Rupai: saphabhirevabadnathya***

Forms seventh-level-upto-superposes

***athmaanamaathmana***

-self-potential-by-self potential

***prakrithi :***

oscillatory waveforms

***saiva cha purushartham prathy***

equal to nuclear-potential but

***vimochayatya eka rupena .***

process of release by one form.

**Meaning:** The oscillatory waveforms superposition itself by its own self-potential to form the nuclear density by compressing it's waveforms to the seventh power when it becomes equal to the maximum nuclear potential in coherent form and when it expands and radiates it releases one waveform at a time.

**Explanation:** The nuclear potential is created by itself due to its coherent state and the levels of superpositioning action rises to seven when it equals the maximum potential that can be maintained by the interactive state in resonant balance. As explained in Suthra 3 an intercation higher rate of intercation drifts towards lower rates because of nonsynchrony. Only if an interactive stress form is countered by a similar stress form at the same rate can the location of the intercation remain at the same position cycle after cycle. Else the point of impact or collision must move toward another location. This drift seems to be a force of attraction. Hence if a countering stress form fails to meet on oncoming one it will ultimately end up at the very source of the opposing one. That leads to aggregation and superpositioning which results in a larger number of

Secret Of Sankhya: Acme Of Scientific Unification.

counts being registered within a cycle. Hence density or mass has increased.

**Mathematical formula:** The moolaprakrithi My interaction at the ultimate level rises to seven when the mahad prakrithi Mps reaches oscillatory states superpose to attain the coherent state. Then the entire ensemble oscillates as one single unit. When it breaks coherence it releases one entire set or ensemble in one instant as a vrithi. It is equal value to a unit electric charge based on planck's constant and is shown below.

Equation S 63. The superpositioning density by synchronising along all three axis as K leads to the maximum density Dp and release of one level equals a unit of charge. Dp is the value of planck density and the charge Eo equals the electronic charge as shown below. It is the ultimate self-similar density of Mps.

$$K = \left(\frac{1}{2}\right)^{\frac{1}{3}} = 0.79370053 \quad Dp = \left[ \left[ \frac{c^{1+x}}{(K)} \right]^7 = 4.56910197 \cdot 10^{96} \right]$$

$$\text{Unit} = Dp^{\frac{1}{7}} = 6.43498093 \cdot 10^{13} \quad Eo = \left( \frac{h \cdot C \cdot \alpha}{2 \cdot \pi} \right)^{-\frac{1}{2}} = 6.58372014 \cdot 10^{-13}$$

The values of h , C and alpha are from figures published in standard physics texts based on natural units. These are shown in the section on Symbols.

Equation S.63 A. Because Dp is created on its own potential the interaction has a simultaneous balancing density Dm. It is the density of MahadVikrithi or Me . The release of one unit is the electronic charge coupling constant.

$$Dm = (c^{1-x})^7 = 4.49237335 \cdot 10^{22} \quad Dm^{\frac{1}{7}} = c^{1-x} = 1.72213811 \cdot 10^3$$

## Secret Of Sankhya: Acme Of Scientific Unification.

The Mahadprakrithi and Mahadvikrithi are the compressive and expansive oscillatory counterparts due the polarisation of  $c^{14}$  into  $(c^{1+x})^7$   $(c^{1-x})^7$  simultaneously or within the interactive cycle.



**Suthra 64.**

64. The coherent self-potential creates ground state.

*evam thathvaabhyaasannaasthi*  
confirmed fundamental-research non-existence  
*na mey nahmithyaaparishesham .*  
not interactive confinement-measure-supplementing  
*aviparyayadvishudham*  
unchanged-undistorted  
*kevalamuthpadhyathe jnaanama*  
singular-source-of-origin potential-sink

**Meaning:** Therefore fundamental research establishes that non existence (of potential ), and not due to any precise interactive measure of supplementary control, that a pure changeless ground state exists.

**Explanation:** Special attention is drawn to the cause of the existence of a ground or zero state towards which interactive activity will drift towards. Here total synchronisation in timing between axis causes the apparent reduction or disappearance of of interactive response or reaction and therefore the interactions at a higher rate of oscillation drift or transmigrate towards the lower state. It seems as though it is attracting the interactions towards a source that seems massive and slow to respond. But that is just an appearance of an attractive forceacting at a distance which does not really exist.

When in interactive stress transmigrates across the components, an opposing interaction would end it by an interactive exchange. However if the opposing reaction fails to appear then the original stress transmigration ensemble would continue till it is opposed. If the rate of opposing interaction is very low or nil the other is absorbed as a synchronously vibrating stress count. The  
369

Secret Of Sankhya: Acme Of Scientific Unification.

inactive state increases by the stress count value that is reflected as an increase in inertia, mass or delaying ensemble. The increment occurs because it synchronises with the lower rate vibration or oscillation and attains a relatively restful or passive state. Though the total stress count has increased it seems to oscillates at a lower rate because many counts act together or simultaneously. As an example of ten people clap individually one after another cyclically the ten counts per cycle is detectable. But if all ten people clap together, only one massive count would have been detected, over a longer time interval. The total count per cycle however remains the same. This is the reason that the rest mass radiates  $c^2$  counts of vibrations as energy because the vibrations along two axis that was synchronised and was counted as  $c$ , now on release, becomes non synchronous and the counts are detected individually.

Stating it differently the superposed nuclear density is only due to the slower interactive response and the oncoming interactive states sink into this lowest activity state of  $Kx$ .

Equation.S.64.  $Kx$  the Purusha state in the coherent superposed phase of  $c^{3-2}$  equals a single Mahadparakrithi Mps state. The Prakrithi saptha or PM in the synchronous state shows the Purusha potential has been reduced by  $c^2$  to allow the PM build up. The PM state grows into the Mps state as  $c^3$  superposes and synchronises along two axis in exchange for allowing  $Px$  to be absorbed along the axial direction over the spectrum of  $7rs$  levels. Similarly the Vikrithi saptha Ne state tunnels to increase  $c^3$  to  $c^4$  in exchange for interactive synchrony along two axis at the boundary of the 7<sup>th</sup> spectral level.

370

$$\left( \frac{Kx}{c^{3-2}} \right) - \frac{Mps}{7 \cdot rs} = 0 \quad \frac{Kx}{c^{3-0}} - PM \cdot Px = 0$$

$$\frac{Kx}{c^{3+1}} - \frac{Ne}{\left[ (2^n \cdot A_n \cdot 2)^2 \cdot 2 \cdot rs \right]} = 0$$

## Secret Of Sankhya: Acme Of Scientific Unification.

The Kx state being the densest andhathamisra state absorbs the interactive counts to maintain its amaximum mass of the coherent potential as a ground or activity sink, like a heat sink.



**Suthra 65.**

65. The state of coherence when the nuclear boundary is in balance.

***thena nivritthaprasavaamarthavashaath***

consequently hidden-source-potential-absorb

***saptharupavinivritthaam.***

Seven-forms-reducing-boundary-activity

***prakrithim pashyathi purusha:***

oscillations-inactive- nucleus

***prekshakavadhavasthhith: svastha:***

Ground-state-location coherent state.

**Meaning:** When the oscillatory interactions are minimised because of the reduction in activity between the boundary and nuclear core, the interactive current becomes neutral and the activities at the seven radial levels becomes insignificant, the Purusha attains a dense superposed coherent ground state.

**Explanation:** As the interactions move towards the nuclear location because the interactive reaction comes at a slower rate as it combines together by synchronisation and though the overall count number remains the same but the response interval becomes longer. The count numbers at twice the radial level would reduce by  $2^2 = 4$  at the radial level by cobining into sets of 4 through synchronisation. Hence the interval too woud lengthen proportionately. At half the radial level it woud reduce the count again by the same factor and similarly increase the interval. As a result an exponentially increasing count rate would transmigrate towards the nuclear region that would have gained counts in incremental sets while the interval would have increased by a similar rate. When the entire nuclear ensemble reaches a resonant rate consistent with the states surrounding it to

Secret Of Sankhya: Acme Of Scientific Unification.

maintain a synchronous in step oscillatory rate the inflowing counts would be balanced by the oscillation of the entire boundary of the nuclear region in a coherent but oscillatory state.

Equation S.65. The first expansive state of  $2^3 = 8$  at resonance

Reaches a coherent level by absorption or superpositioning of oscillations that sums up to  $1/7$ . The absorption of counts by expanding in two modes of radial and linear sequences reduces the Purusha state to just  $1/7$  as shown below.

$$\frac{1}{\sum_n \left(\frac{1}{2^3}\right)^n} = 7 \quad \frac{8 \cdot Kx \cdot rs}{10^x \cdot k} - \sum_n \left(\frac{1}{2^3}\right)^n = 0$$

Equation S.65A. The interactions at the boundary combine and synchronise to act together and thereby the decrease in count rate motivates the transmigration of counts towards the coherent level. The ratio of  $Mps/Kx$  and  $Mps/PM$  absorption of counts shows the spectrum of seven levels are involved both ways.

$$\frac{Mps \cdot c^{3-2}}{Kx \cdot rs} - 7 = 0 \quad \frac{Mps}{PM \cdot Px \cdot c^2 \cdot rs} - 7 = 0$$

Equation S.65 B . The neutral or ground level Vrithi Ne or photon has a neutral current of approx.  $1/49^{th}$  at balance. Hence the activity at the boundary remains at a fraction but not inert and indicactes a synchronous activity but not coherent state

$$7 - \left[ \frac{PM \cdot (7)^2}{(Ne \cdot c) \cdot (k-1)^2} \right] \cdot \left[ \frac{rs}{2^n \cdot A_n \cdot 20} \right] = 0.02086974$$

Secret Of Sankhya: Acme Of Scientific Unification.

Equation S.65 C. The activity at the Prakrithi-saptha or PM and Mahadvikrithi or Me boudary is at 1/343<sup>rd</sup> level.

$$\left[ \left[ \frac{PM \cdot (k-1)^2}{(Me) \cdot (7)} \right] \cdot \left( 2^n \cdot A_n \cdot 2 \right)^2 \right] - 7 = 0.00293825$$





**Suthra 66.**

66. State of balance by eliminating the potential to act.

***Dhrishta mayethupekshak ekau***

observation consisting-variety-neutral one

***drishtaahamithyuparamithyanya .***

observation-movement-measure-ceases-other .

***sathisamyogey'api thayo.***

Existence-adjacent even though

***prayojanam nasthi sargasya .***

benefit non existence manifestation .

**Meaning:** Observing the neutral state of one gives the proof that the observable movement of the other has ceased and now even though both are together no interactive manifestation can be detected.

**Explanation:** As the nuclear boundary is in a lower state of vibration and registers a lower count rate, the measure of activity can be gauged or detected by observing the state of the outer resonant boundary. But when that activity level too becomes undetectable then there is no transmigration of interactive responses to trigger or display any type of manifest phenomenon.

Equation S. 66. The difference at the interface where the Prakrithi Saptha or PM and the Mahad Vikrithi or Me attain balance at the minimum rate of 3 or 4 interactions per cycle show the negative value at 3 and positive at 4 index

$$\boxed{\frac{\text{PM}}{\left(\frac{7}{k-1}\right)^2} - \text{Me} \cdot \left(\frac{1}{2^3 \cdot A_3 \cdot 2}\right)^2 = -2.17887266 \cdot 10^{-34}}$$

Secret Of Sankhya: Acme Of Scientific Unification.

The value at 4 though positive is just 1/18 in excess of the value of 7 Ne's needed to radiate a vrithi or photon that could be measured . Hence at the resonant interface the

interactive activity is extremely small and is not detectable as a positive radiative value.

Equation S.66 A, shows the positive value at index 4. The positive value equals exactly 377 electron volts of energy and as a unit of charge contributes an ampere/sec the impedance is 377 ohms.

$$\frac{PM}{\left[\left(\frac{7}{k-1}\right)^2\right]} - Me \cdot \left(\frac{1}{2^4 \cdot A_4 \cdot 2}\right)^2 = 6.7212708 \cdot 10^{-34}$$

Equation S.66 B, shows that the positive value at the interactive rate of 4, is just 1/18 over the value a 7 vrithi rate required to radiate a detectable count rate.

$$\frac{\frac{PM}{\left[\left(\frac{7}{k-1}\right)^2\right]} - Me \cdot \left(\frac{1}{2^4 \cdot A_4 \cdot 2}\right)^2}{my \cdot c^2 \cdot \left(\frac{2^4 \cdot A_4 \cdot 20}{7}\right)^2} - 7 = 0.05459359$$

The essential nature of this interface remains at a gentle interactive level till a disturbance triggers an unbalanced state to motivate transmigration of counts both ways. The 1/18<sup>th</sup> corresponds to the 18 andhathaamisra states and unless all 18 states are triggered simultaneously no Vrithi or Photon will be radiated. It decays when all 18 coherent  
378

Secret Of Sankhya: Acme Of Scientific Unification.

levels are reduced to one over a time cycle duration of  $T^*T=2.02084475E+17$  or 6.4 billion years.

### Suthra 67.

67. Conversion of kinetic force into static potential as inertia or mass

***samyagjnanaadhigamadharmadinam***

synchronously-potential-acquire-by-axiomatic-laws

***akaaranapraptau.***

selfsimilar-process.

***thishtathi sanskaaravashaa***

triggered\_input-reactions-absorbed

***chakrabramhavaddhrithah sharirah.***

like-flywheel-rigidity

inertial mass

**Meaning:** The basic principle of acquiring a mass is by synchronous superpositioning of oscillatory interactions on components into a coherent and super symmetric state that is relatively static by triggering the spin angular momentum to be synchronised perfectly. Thereby acquire a coherent potential or dense state by superpositining of interactive states by a self similar proportion or law .

**Explanation.** The enigma of how the mass of solid bodies could be formed by vibrations or oscillatory stress in the real field of space. The derivation of many principles in the previous Suthras are used to construct the process of generating a body with mass or solidity characteristics from a purely oscillatory state. The axiomatic causes of why detection becomes impossible was explained. Further it was shown the three guna states could not exist unless there was a background state with specific qualities. The

Secret Of Sankhya: Acme Of Scientific Unification.

point of discussion here is that when vibrations synchronise and act simultaneously as a coherent unit then the fundamental components in space get defined and its outline gives characteristics of solidity or substantiality. When interactions act in the same place they seem to be stable. Again when the number of interactions in a single location increases then the characteristics of firmness, solidity or inertial states that display qualities emerge.

In order to sustain the vibrating state the laws of perpetual oscillations governed by the principle of self similarity in a confined domain are needed to maintain that state. The Suthra puts these factors together to show through the concept of a flywheel how the momentum built up keeps the spinning object in that state. While it is an analogy, the principle of self similarity is emulated by the flywheel concept. The mass in motion is always moving ahead of a location in a small fraction of time. Hence any change to the flywheel motion must be initiated to precede the location at which the change is required. Self similarity qualities in the three guna laws do that precisely. Three levels of absorption of counts will be shown as an example of how mass is acquired by converting angular momentum.

Equation S.67. Shows the derivation of  $(2\pi/10)$  as an interaction. Since all three axis must be in an identical state to maintain coherence the 'spin' at boundary yields  $P_x$  as the absorption value.

$$n=x=y=z \quad \left(2^n \cdot A_n \cdot 2\right) = 0.62831852$$

$$P_x = \left[ \left(2^n \cdot A_n \cdot 2\right)^{-2} + \left(2^n \cdot A_n \cdot 2\right)^{-2} + \left(2^n \cdot A_n \cdot 2\right)^{-2} \right]^{\frac{3}{2}} = 20.9479861$$

Equation S.67A. The ratio of  $K_x$ , the Purusha state to PM the Prakrithi saptha or nucleonic state per cycle is  $P_x$ . Similarly the Mahadrakrithi  $M_p$ s has the same ratio  $P_x$  when  $c^3$  has reduced to  $c$  by synchronising along two axis

380

Secret Of Sankhya: Acme Of Scientific Unification.

in exchange for 7 rs incremental cycles of the PM expanded state.

$$\frac{Kx}{PM \cdot c^3} = 20.9479861 \quad \left( \frac{Mps}{PM \cdot c^{3-1} \cdot 7 \cdot rs} \right) = 20.9479861$$

very effectively shows that the absorption of  $c^2$  for 7rs has changed the Kx state to the Mps state within the Px cycle. The conversion of angular momentum to a coherent state is confirmed by the equivalence of Px.

Equation S.67B.

$$\frac{Ne \cdot c^4}{PM \cdot c^3} \cdot \left( \frac{7}{2 \cdot \pi} \right)^2 = 20.9479861$$

The Ne Vikrithi Saptha has increased by c into K7 times to create the Prakrithi saptha state of coherence at the nuclear boundary within the same Px cycle. Therefore Kx, Mps, PM and Ne are all equivalent states in varying cyclic periods and can maintain the coherent state when synchronised along all three axis. In that state no manifestation would be evident as the oscillatory phases operate in the self similar mode inside the coherent boundary. The point at which two axis synchronise is determined by the vectorial difference in the interval between two adjacent oscillatory states. If the interval between two adjacent sequences as n and n+1 is smaller than  $1/(c^{1+x})^2$ , which is the smallest interval possible between oscillatory states between two axis, then the discriminatory interval becomes virtually nil. Hence two interactions would act simultaneously when the difference

381

Secret Of Sankhya: Acme Of Scientific Unification.

in the interactive interval is less than  $1/c^{1+x}$  as shown below.

$n := 20.. 22$	
$(A_n)^2$	$(A_{n+1} \cdot 2)^2$
$8.976352911385283 \cdot 10^{-14}$	$8.976352911385486 \cdot 10^{-14}$
$2.244088227846372 \cdot 10^{-14}$	$2.244088227846384 \cdot 10^{-14}$
$5.61022056961596 \cdot 10^{-15}$	$5.610220569615968 \cdot 10^{-15}$
$\left[ (A_{n+1} \cdot 2)^2 - (A_n)^2 \right] - (c^{1+x})^{-2}$	
$1.648758633502744 \cdot 10^{-27}$	
$- 2.571293135112209 \cdot 10^{-28}$	
$- 3.754584492943727 \cdot 10^{-28}$	

Equat

Secret Of Sankhya: Acme Of Scientific Unification.

**Suthra 68.**

The final synchronised, coherent , dynamic state of isolated nucleus.

*prapthey sharirabhedhey charitharthathvath*

acquiring mass-conversion by synchronous balance

*pradhanavinivritthau*

primary-activity-diminishing-cyclic-vortex

*aikaanthikamaathyanthikamubhayam*

coherence-endless-action-simultaneously

*kaivalyamaapnothi*

perpetual-activity-accomplished

**Meaning.** The process of acquiring mass is given effect by superpositioning the interactive vortex like waveforms by conversion into a gradually diminishing cyclic interaction that reaches a synchronised, coherent and balanced state within the first or primary activity boundary. The coherent state in which activity is simultaneous creates no hindrance to maintain the synchronised cyclic oscillatory action perpetually.

**Explanation:** Recalling that the statements from the first Sutra had defined the conditions needed for the three forms of stresses to exist a state of coherent, perpetual , dynamic but unmanifest state. The gradual superpositioning of interactive stresses by absorption due to reducing interactive counts produced the unmanifest state. That ensured that the superposed stresses would remain in a coherent state as the process of manifestation was solely responsible for unsynchronised and unbalanced activity. Therefore the interactivity being confined within the primary activity boundary following self similar laws assured that the transfer of interactive stresses at the lower

383

## Secret Of Sankhya: Acme Of Scientific Unification.

rate would aid or augment the activity internally and thereby eliminate an hindrance or obstruction or friction or delay that would bring the oscillatory activity to a stop. Therefore as the required conditions for ensuring a free set of conditions that eliminated the triad of stresses had been established the maintenance perpetual oscillatory activity was made certain and therefore accomplished finally.

**Additional Comments:** The first Suthra stated “Investigating the triad of interactive stresses confirms that such interactive modes of stresses exist but it would not have been detectable, had it not been for the existence of the coherent - perpetual - dynamic - unmanifest state of its existence (of the substratum). “

Referring to the first Suthra the logic of the conditional statement in it is proved :The final proof of the entire spectrum of manifestation after sequentially analysing the logical factors is given in this Suthra. The opening Suthra itself follows the principle of looping back to create a circular rationale by choosing a phraseology that elliptically negates itself. The triad of stresses is a reference to the guna interactive states of Thaama, Raja and sSatwa. This Suthra explains how the Satwic nature of the vortex like interaction of the un-synchronised waveforms outside the primary boundary or Pradhana state, drift towards the nuclear centre because it is in a relative state of rest due to the coherent and synchronised condition of the Purusha location.

The Raja region closer to the Sathwa interface has a larger oscillatory count rate but at the other end near the Purusha interface the oscillations combine or superpose together and act simultaneously as a coherent set of synchronised vibrations with a diminished count rate. As the oscillatory ensemble drift towards the centre the superpositioning quality increases the density of stresses residing in it and when the inertia or mass and at a particular point the



## Secret Of Sankhya: Acme Of Scientific Unification.

superpositioning density reaches a maximum , all detectable oscillatory movements synchronise and act together in a coherent breathing mode or a whole spherical surface vibrates as a unit. Therefore the innermost boundary is isolated or screened by the outer spherically oscillating surface. The inner, static, stationery, passive, dense with maximum number of oscillations simultaneously occupying this location at the nuclear Purusha core acts as potential sink but because of the screening spherical boundary it can never become active enough to lose its' attracting potential or sink status. The screening spherical surface in the breathing mode is in an interactive Raja state that carries out the change from a sequential oscillatory state to a parallel or simultaneous super posed state. Since this conversion takes place over a rate changing factor of 2, there are (8-1) 7 intermediate levels of change as explained in Suthra 3 , those describing the Guna states and Suthras 63 & 65. The most important underlying principle is that all the descriptions pertain ONLY to vibrations taking place on or in the undetectable components of the substratum The entire theory is based on analysing the holographic state of the substratum.

Mathematical : The most rigorous condition for perpetual oscillations require that every stable state must be capable of the unmanifest or zero radiative level certifying the maintenance of an unhindered or friction free state exists. Here all such states are shown to equal  $2^3=8$ . The symbols are explained in the index section and the derivation in axiomatic derivation section.

Equation S.68.

The perpetual oscillator  
state :

$$\frac{1}{10^x \cdot k} = 8$$

$7 \cdot Kx \cdot rs$

Equation S.68.A

$$\frac{\pi}{e} \cdot x \cdot \left( \frac{10}{7 \cdot rs} \right) = 1$$

Secret Of Sankhya: Acme Of Scientific Unification.

Fundamental unmanifest level:

$$8 - \frac{10^x \cdot k}{7 \cdot Kx \cdot rs} = 0$$

$$\left( \frac{\pi}{e} \cdot x \right) - \left( \frac{7 \cdot rs}{10} \right) = 0$$

Equation S.68B  
Axiomatic coupling  
Constants :

$$\left[ \left( \frac{10}{2 \cdot \pi} \right)^2 \right] - \left[ \left( \frac{7}{2 \cdot \pi} \right)^2 \cdot 2 \cdot rs \right] = 0$$

Equation S.68C  
Space Stress  
Density:  
The neutral level  
manifestation:

$$\left( \frac{Dp}{DD} \right)^{\frac{1}{3}} - \left( \frac{Pd}{DD} \cdot Ge \right) = 0$$

$$\left( \frac{Dp}{DD} \right)^{\frac{2}{3}} - \left( \frac{Dp}{Pd \cdot Ge} \right) = 0$$

$$(Kx \cdot 7 \cdot rs) - (Mps \cdot c) = 0 \quad \left( \frac{Kx}{c^3} \right) - (my \cdot c^3) = 0$$

Equation S.68E  
The Thaamasic or coherent level :

$$\left( \frac{Mps}{c^2 \cdot 7 \cdot rs} \right) - (PM \cdot Px) = 0$$

$$\frac{Kx}{c^3 \cdot Px} - \frac{my \cdot c^3}{Px} = 0$$

Equation S.68F  
The Linga/Bhava interface of Prakrithi-Vikrithi level:

$$\left[ PM \cdot \left( \frac{k-1}{7} \right)^2 \right] - \left[ Me \cdot \left( \frac{10}{2 \cdot \pi} \right)^2 \right] = 0$$

$$\left[ PM \cdot \left( \frac{k-1}{7} \right)^2 \right] - \left[ Me \cdot \left( \frac{7}{2 \cdot \pi} \right)^2 \cdot 2 \cdot rs \right] = 0$$

Equation S.68G  
The Abhiman/Ahankar interface of Vikrithi Vikaro level

Secret Of Sankhya: Acme Of Scientific Unification.

Equation S.68H

$$\left( \frac{PM \cdot Px}{Kx} \right) - (Ne \cdot c \cdot 2 \cdot rs \cdot Ge) = 0$$

The Mass of the Universe is conserved or space is unmanifest:

$$\left( \frac{my}{MU} \right) - \left[ \frac{c \cdot tp}{\left( \frac{1}{2 \cdot x} \right)^2} \right]^3 = 0$$

Equation S.68I

Final proof that all forms of interactive stresses are conserved and the unmanifest state is maintained. Neither should stresses be radiated beyond the radius of the Universe nor should it absorb

from outside the Universal boundary. Vrithis or photons cannot be radiated beyond the radius of the Universe RU:

Equation S.68J

$$\frac{\frac{1}{Ge} + 1}{\frac{Ne \cdot c \cdot 7}{my} \cdot rs} - \frac{1}{RU} = 0$$

Unless the vrithis are absorbed within the boundary the balance in maintaining the space density at the critical level that would ensure non absorption of stresses from outside its boundary is needed as proof. For they may not be stresses outside the boundary but rigor of logic is maintained by that proof: Equation

The stressess in the substratum are kept in oscillation for a very efficient reason. Oscillations compress and expand alternately creating two opposing types stressess. If there is a delay then the different stresses will oppose each other to set in the process of decay that will eventually reduce the motivating cause for the oscillation. But if the two opposing forms of stress can be timed such that it aids

387

## Secret Of Sankhya: Acme Of Scientific Unification.

each oscillation in the right direction at the right time then it can continue endlessly. But to continue perpetually no work or or energy output should take place for only then the infinite time aspect can be logically supported. Again to fulfill the no work state there should not be any observable movement. If there is no movement or no change in short such a state cannot be detected, for detection is a relative measuring process. Then the substratum would seem passive, static, quiet, inactive and so on. Only the transmigration of stresses would continue as a hidden activity that does not involve the expenditure of energy. Then it would seem flat.

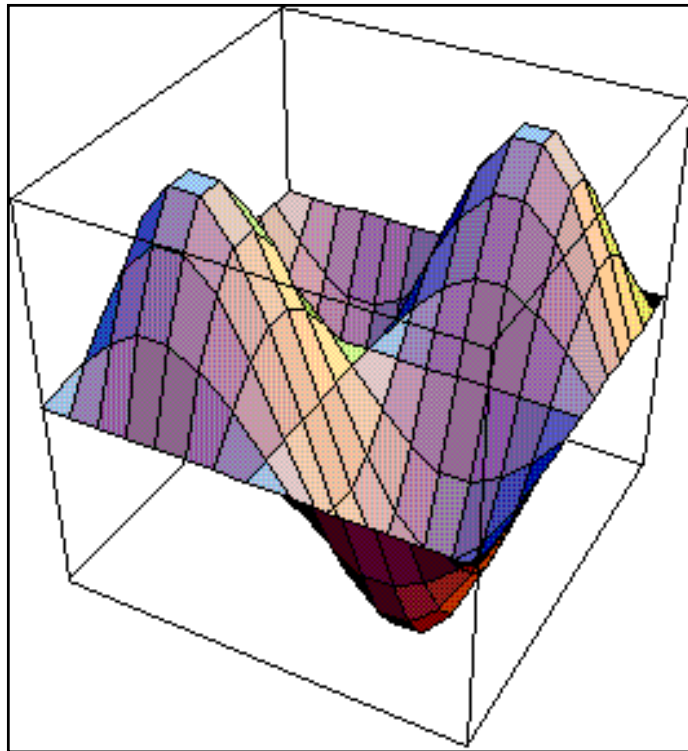

Fig. The Coherent Perpetual Oscillator .

The graphic displayed above shows the stresses in the substratum as though a membrane exists at the neutral location. But in real terms nothing would be detected

388

## Secret Of Sankhya: Acme Of Scientific Unification.

unless the vibrations remained in the same location as a coherent stress form thus fulfilling the holographic state fundamentals. Lower diagrams show the three phases of change within a cycle as three oscillatory phases. The middle phase displays a flat state of zero activity and as long as the stress excursions remain equal above and below the neutral state the net result of all the oscillatory activity will be zero within the cycle. The stress transmigration takes place when the 90 deg. Phase difference of the coherent cycle is upset which results in a wave transfer that seems to be a quadrupole rotation. Observation averaged over a cycle will display the flat state in the middle diagram. Hence space seems undetectable.



Secret Of Sankhya: Acme Of Scientific Unification.

A.Positive excursion of oscillation

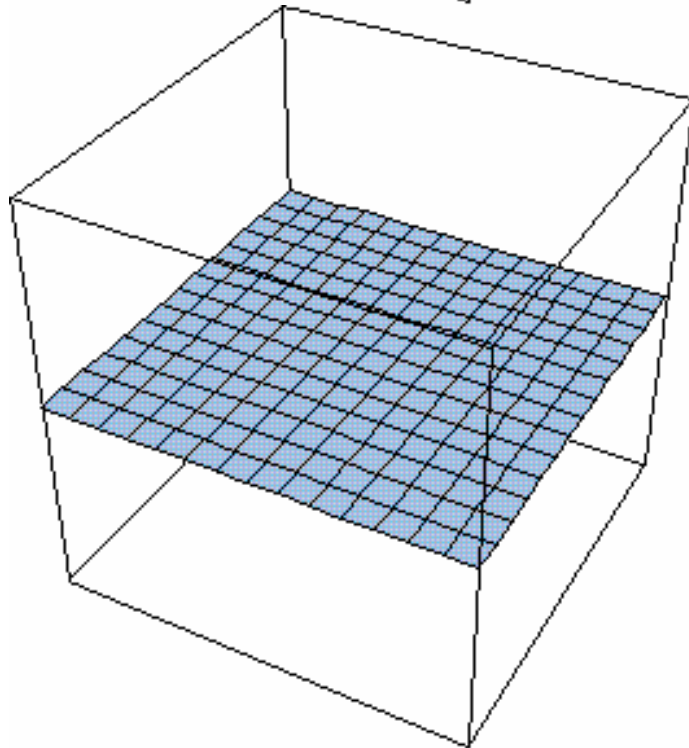
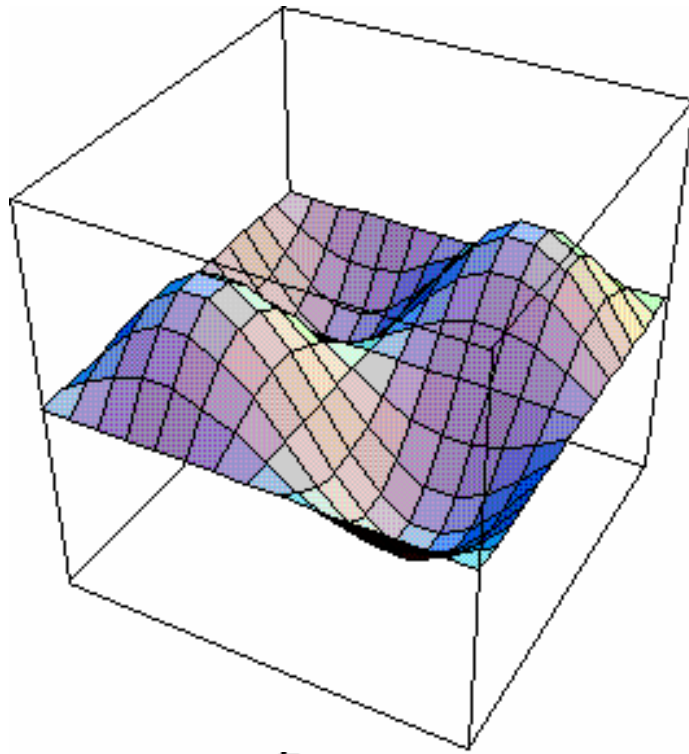

Secret Of Sankhya: Acme Of Scientific Unification.

B. Neutral excursion of oscillation.

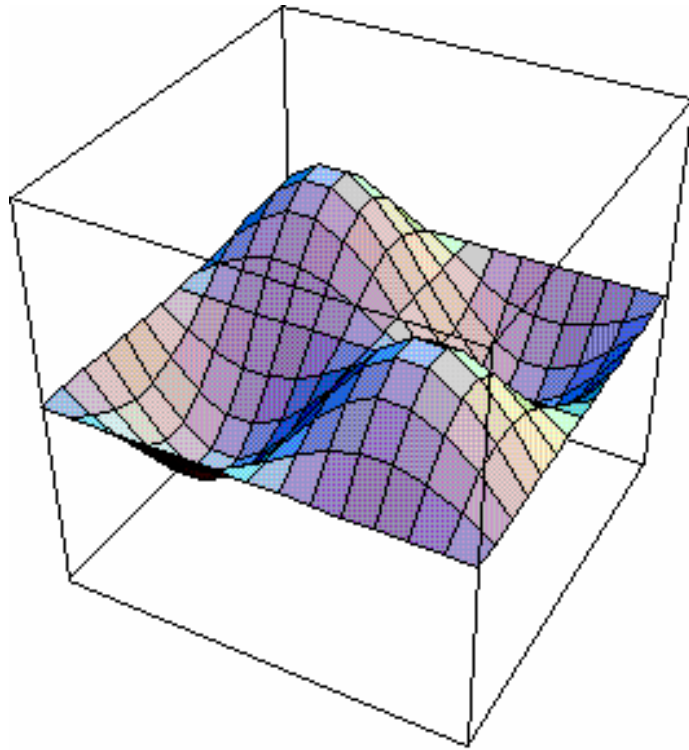

Fig. A,B,C. The Neutral Oscillator State.

C. Negative excursion of oscillation.



Secret Of Sankhya: Acme Of Scientific Unification.

**Suthra 69.**

The knowledge of the nuclear potential is codified in this work

***Purusharthajnaanam idham***

nuclear potential theory in this work

***guhyam paramarshina samakhyatam***

secret by the greatest maharishi encoded or framed

***sthithi-yuthpatti-pralayas***

origin growth and dissolution

***chintyante yatra bhuthanam.***

intellectual ascertainment of existing reality.

**Meaning:** The knowledge of the nuclear potential is encoded in this work by the great Maharishi where-in the method of intellectually ascertaining the process of manifestation of phenomenon from its origin, through its growth and till its dissolution are explained.

**Explanation:** The essence of this entire intellectual creation was to lay bare the process of the complex holographic interaction in three modes within the substratum, which was defined in the first Suthra and was proved unequivocally by an elliptical logic connecting Suthra 68. The core principal identified the ever present potential at the nuclear centre as the primary cause. Being a complex intellectual process, the Maharishi took precautions to ensure its correct interpretation by the following process.

The process of disseminating knowledge through the ages, in Vedic times, was by vocal recitation of logical theorems or aphorisms and it was handed down to the next generation. The method was perfected by a brahmanical system of training that made sure of the correctness of information so transmitted. In order to doubly ensure that the essence of the core principles were transmitted in its

393

## Secret Of Sankhya: Acme Of Scientific Unification.

original and pure form, the Maharishi had encoded the vital information into the Suthras that apparently had a general everyday meaning and also gave a method of extracting the original meaning , intact and correct, in Suthras 4, 5 & 6. Since there was every possibility of the information getting corrupted, either in ignorance or intentionally, the encoding process provided a high degree of immunity. Since the information had to be transmitted through generations of students , there was always the temptation to alter or modify apparently un-understandable abstruse or complex information into more meaningful structures. The Maharishi had the intellectual acumen and skill to weave in the axiomatic theorems into a skeletal framework of mundane statements which provided logical continuity and intelligibility and at the same time the needed immunity from restructuring the Suthras. In Suthras 70, the history of the handing over process is specifically mentioned to demonstrate it's integrity of transmission.

Secret Of Sankhya: Acme Of Scientific Unification.

**Suthra 70.**

The hierarchy of information transmission

*ethath pavithramagrayam t*

this pure-highest-doctrine

*munirasuraye'anukampayaa pradhadhau*

the sage asuri with understanding handed down

*aasurirapi pancasikhaya*

from asuri to panchasikha

*tena cha bahudhaa krtham thanthram*

by whom it was extensively propagated doctrine

**Meaning:** This pure and highest doctrine the sage gave to Asuri who in turn handed down to Panchasikha by whom it was extensively propogated as the perfect set of principles explaining the mode of action in reality.

**Explanation:** The eminent disciples or students of the great Sage followed the brahmanical process of handing down knowledge through generations mentioned earlier.

The final process of handing over this doctrine down the line culminated with Ishwarkrishna.



Secret Of Sankhya: Acme Of Scientific Unification.

**Suthra 71.**

The final verification and recording by Ishwarakrishna.

*Shisyaparamparyaagathamishwarakrishnanena*

*chaithadaaryabhi*

*samkshipthamaaryamathina*

*samyaagvijnyasiddhanthau*

Meaning: Handed down by disciples in succession to Ishwarakrishna of noble mind, it has been written in a complete and understable way in the Arya metre after verifying the correctness and presented with full conviction of the truth of this theory.



Secret Of Sankhya: Acme Of Scientific Unification.

Axiomatic Mathematics From Suthras.

### **Introduction**

The process of detection, measurement, observation, defining and characterising are based on relational logic. Essentially it is a process of comparison implying that objects are necessary to make it meaningful. Therefore absolute values have no relevance for it cannot be compared to establish a logical, scale or proportionality. Hence, one, the first unit can be made relative by comparing it to another one. One/one is one and so is infinity / infinity and also forms its own reciprocal. The  $1/1$  or  $N/N$  or infinity/infinity is an identity of a state. The singular, coherent, simultaneous state of Aikantha. Yet the  $N$  or infinity is a sequence of incremental numbers which can represent the number of interactions that have taken place simultaneously. Any state that can be identified has a distinct characteristic of one as  $1/1$  or  $N/N$  etc. or difference of zero as  $(1/1)-(N/N) = 0$ . Such a characteristic is defined as the Linga phase in an interactive environment.

The converse of the above is an open ended spectrum of non-identities or plurality of phases of difference states. The limit of such states is as large as  $1/\text{infinity}$ . In effect all such states that cannot be included in the identities fall into the phase called Bhava or forms. Axiomatically all phenomena can be classified by numerical values only when they are perceived as 3 dimensional states. While the Linga or coherent states are simultaneous the Bhava states are sequential states. While  $1/1$  or  $N/N$  identifies a simultaneous state the sequential state has to be  $1+1$  etc. Taking the sequential state as the commencement of the unbalanced or unsynchronised or non-coherent or a non identity then it can be symbolically shown as  $1 + x$  and its reciprocal as  $1/1+x$ .

The essence of an identity is the equality of that ratio to one. Therefore if a sequence can be expressed as a ratio of

## Secret Of Sankhya: Acme Of Scientific Unification.

one then it too attains an identity or the Linga classification. That is if a value  $(1+x/n)=1$  and if it can be further simplified to  $1+x = 1/x$  then a unique state prevails. At this point simultaneous state equals sequential state or Linga equals Bhava . Rephrasing, it defines the commencement point at which cyclic time-period equals the sequential cycle. Hence static and dynamic cycles can be compared as an equal identity and can be commuted to either classification. The starting point for a sequential time period is the point at which manifestation can be detected as an emerging Bhava. A clock is an indicator of a cyclic movement and is based on an arbitrary division. But an interaction between similar objects sets up a relational cycle, following the principle of 'self-similar' proportionality.

The concept of a potential is clarified as the coherent state in which any number of sequential time-cycles are organised or stored within one time cycle. The Linga state is the potential 'static like state' of near infinite Bhava states. Potential can be described as unreleased or stored stresses and when freed it moves or accelerates as a kinetic force. The identity or the equality is defined by the expression  $1+x = 1/x$  or taking it to infinite levels it is  $(1+x)^n = 1/x^n$  ; hence  $(1+x)^n (x^n)=1$  . The coherent state is now definable in terms of sub-states or nested level values by a single value of x. The concept of self-similarity or swabhava is brought out as an explicit principle that quantifies the coherent states which can be discriminated to finer or subtler levels as relational value to the Bhava state of activity in an interactive environment. It unifies static and dynamic concepts meaningfully by a single factor.

The unit one above has the unique characteristic of retaining its identity while it is able to differentiate into infinite nested level values without losing its proportionality. Differentiating one does not lead to zero for  
400



## Secret Of Sankhya: Acme Of Scientific Unification.

it always has the ratio of  $1/x$  in relation to its sequential reciprocal  $1+x$ . Adding 1 to 1 creates the next step in the sequence to the value of its sum as two. It is a ratio as  $2/1$  and its reciprocal  $1/2$  has two unique characteristics. It defines the centre of a cyclic time period or a length. Half forms the maximum gradient as a third, quarter, fifth etc are smaller ratios. Therefore  $1/2$  forms the limit of a change in a relational state and all expressions for rates of change can be derived from within this ratio. Being the greatest ratio it is called Mahath.

Taking 2 as the incremental, relative spatial or volumetric will increase proportionately as  $2^3 = 8$ . The relative difference between the two states will therefore be  $8-1=7$ . If this difference of 7 units are coherent, synchronous or identical the identified difference per cycle of change will remain 7. But if there is a loss of synchrony, coherence, phase or identity, the 7 will increase to  $7^3 = 343$ . Rephrasing it differently, the increment or expansion of the Linga state by the maximum rate of two in a state of freedom from constraints, the maximum Bhava forms possible  $7^3 = 343$  variations and the minimum cyclic period as the reciprocal will be  $1/343 = .002915$ . It defines the maximum period in a cycle where one particular form or state of interaction will prevail. (In quantum physics blackbody radiation maximises at a wavelength of .0029 metres where velocity of light is in meters/sec. Also the Atharvaveda's first Sloka mentions 343 forms that move about freely are the cause of dynamic phenomenon.) Because all other intervals will be proportionate to a smaller gradient the value of  $1/343$  will be the maximum. A gradient of  $1/3$  will result in a shorter cyclic period on the same basis; as  $1/(3^3-1)^3 = 1/26^3 = 1/17576$ .

Combinatorial forms based on a maximum interactive ratio of 2 would form the limit. Aggregation of such forms would proceed on the same proportionality of  $1/2$  or 2 as the ratio. Hence a combination of two neighbouring states

401

## Secret Of Sankhya: Acme Of Scientific Unification.

as  $n$  and  $(n+1)$  will follow the expression  $(n^2 + n)/2$  will result in a series as 1, 3, 6,10,15,21,28,36,45,55 etc as the sum of values incremented by one at each step or cycle. This process seeks the incremental value at the next sequence or is future oriented. It progresses on the basis of a sequence formed by incremental time cycles.

The process of adding past values or states that exist results in a series with a fixed ratio of increment. As  $0+1=1$ ,  $1+1=2$ ,  $2+1=3$ ,  $3+2=5$ ,  $5+3=8$ ,  $8+5=13$ ,  $13+8=21$ ,  $21+13=34$ ,  $34+21=55$  and  $55+34=89$  etc. But the ratio or gradient of the increment remains constant as  $1+x=1.618$ . Comparing this gradient or ratio with the maximum ratio of 1 by 2 results in a vectorial increment rate. The process of adding instantly or simultaneously leads to a multiplicative or logarithmic process. Then the past state of 2 can be only in a cubic or three dimensional form of  $2^3 = 8$ . Any sequential or time involving adding process leads to  $8+2 = 10$  which is the first possible state from the past form. Therefore it forms the first detectable cycle when simultaneous and sequential processes act on an equal foundation. Next, the simultaneous increment, and leads to  $8 \times 2 = 16 = 2^4$  as detailed in Suthra 30.

Note: As the logical order of the compact Sutras in Sanskrit are different from the normal methods used in the present scientific system of presentation, Part 1 has been specifically rewritten to reorder the mathematical presentation. Hence all detailed mathematical information is contained in Part 1 and is presented in a way that makes it independent of the run of logic in Part 2.

However a few of the constants are derived here for immediate reference.

### Numerical Derivation.

Unit = 1.

Ratio =  $[1/1] = [N/N] = [\infty / \infty] = 1$ .

Polarisation ratio  $Pr = N / [N-1] = 1 + (1 / [N-1])$

If  $N=1$  then  $1/1-1 = 1/0 =$  not evaluatable.

Secret Of Sankhya: Acme Of Scientific Unification.

If  $N=1+1=2$  then  $2/[2-1] = 2/1$  or  $1 / 2$ .

If  $N= \infty$  then  $\infty /[\infty - 1] = 1 + [(1/[\infty - 1]) \approx 1$ .

Therefore Maximum Prm is  $1 / 2$  or  $2 / 1$ .

Mahadh =  $1 / 2$  or greatest ratio of interaction.  
(AM1)

Simultaneous =  $1/1] = [N/N] = [\infty / \infty] = 1$ .

Sequential =  $1 + [(1/[\infty - 1])$  to  $1 + (1/ [N-1])$

Therefore numerical values greater than 1 as 2,3 ,4 etc are correct only if it is measured as simultaneous ratios as 3/1 etc.

Series of incremental nos=  $1+2+3+4+5 \gg (n^2 + n)/2$

As 1,3,6,10,15 etc.

Series of existing nos=  $1+1=2; 2+1=3, 3+2=5, 5+3=8,$   
etc

Interactive change ratio =  
(AM2)

$$\frac{\sqrt{1^2 + 2^2} - 2}{2} = 0.1180339$$

Self-similar change of Prm  $1 / 2 = 0.5$

In simultaneous mode if  $x = 0.5 + 0.118034 = 0.618034$ .

Then simultaneously  $x^2$  must =  $0.5 - 0.118034 = 0.381966$

Hence simultaneous difference  $0.618034 - 0.381966 = 0.236068$

Therefore  $x^3$  must =  $0.1180339 + 0.118039 = .236068$

If  $(x-x^2)$  is not equal to  $x^3$  the simultaneous state is broken.

Therefore the ratio  $x^3$  provides a damping constraint to maintain the simultaneous mode of interaction else it remains a sequential interaction.

Field consists of numerous points in a volume of space. The point remains in the same location because all three axis from all the cardinal directions meet at the same point simultaneously.

Any volume of space is

Therefore if the unit of interactive count is 1 then 1

Secret Of Sankhya: Acme Of Scientific Unification.

$$\frac{\left[ \sqrt{\frac{G}{\left(\frac{PM}{Rp^3}\right)}} \cdot Kx \cdot rs \right]}{PM} = 6.0242184582 \cdot 10^{23}$$

$$\frac{\left[ \sqrt{\frac{G}{\left(\frac{Dp}{DD}\right)^{\frac{1}{3}} \cdot \frac{DD}{Ge}}} \cdot Kx \cdot rs \right]}{PM} = 6.0242184582 \cdot 10^{23}$$

The Avogadro number is an axiomatic parameter based on the time interval created by the nuclear density.

$$\left(\frac{Dp}{DD}\right)^{\frac{1}{3}} \cdot \frac{DD}{(c^x)^3 \cdot Kx} \cdot \frac{Px}{KV} = 0.6647897608$$

$$\left(\frac{Dp}{DD}\right)^{\frac{1}{3}} \cdot \frac{DD}{Pd} = 0.6647897608$$

$$\frac{\left(\frac{Mps \cdot RU^3}{Lp^3 \cdot MU}\right)^{\frac{1}{3}}}{\frac{RU^3 \cdot PM}{MU \cdot Rp^3}} = 0.6647897608 \quad \frac{\frac{Mps \cdot Rp^3}{Lp^3 \cdot PM}}{\left(\frac{Mps \cdot RU^3}{Lp^3 \cdot MU}\right)^{\frac{2}{3}}} = 0.6647897608$$

The basic mathematical axioms.

The numeral one is a ratio signifying equality or zero difference. The value of a count is a relative parameter and 1 count is 1 count per unit cycle.

$$\frac{104}{Kx} = 22.898689 \log\left(\frac{1}{x}\right)^{(-2)} = 22.895957 \left(\frac{1}{x+x}\right)^6 = 0.280379$$

$$\frac{MU}{my} \cdot Lp^3 = 0.280393 \quad \left(\frac{my}{Ke \cdot DD \cdot 7}\right) = 0.280523$$

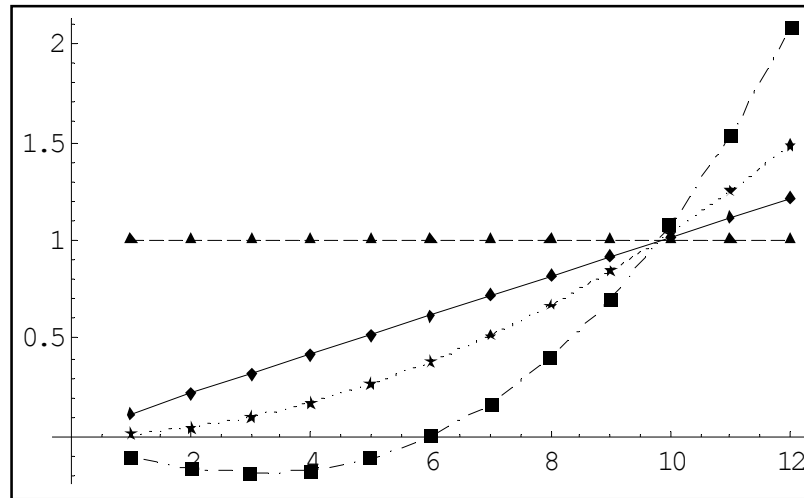

Fig: Derivation Of Cyclic Counts

The straight line= D and dotted id= D<sup>2</sup> while squares = Dx.

$D1 := \frac{x^3}{2} - \frac{1}{10}$	$D_n := \frac{n}{10} + D1$
$Dx_n := \left[ (D_n)^3 - \left[ D_n - (D_n)^2 \right] \right]$	
Dx <sub>n</sub>	
- 0.1024575141	
- 0.1601300899	
- 0.1847206264	
- 0.1702291236	
- 0.1106555815	
5.5511151231 · 10 <sup>-17</sup>	
0.1677376208	
0.3985572809	
0.6984589803	
1.0734427191	

Secret Of Sankhya: Acme Of Scientific Unification.

The axiomatic cycle of 10 counts is derived from the synchronisation of different additive and subtractive results.

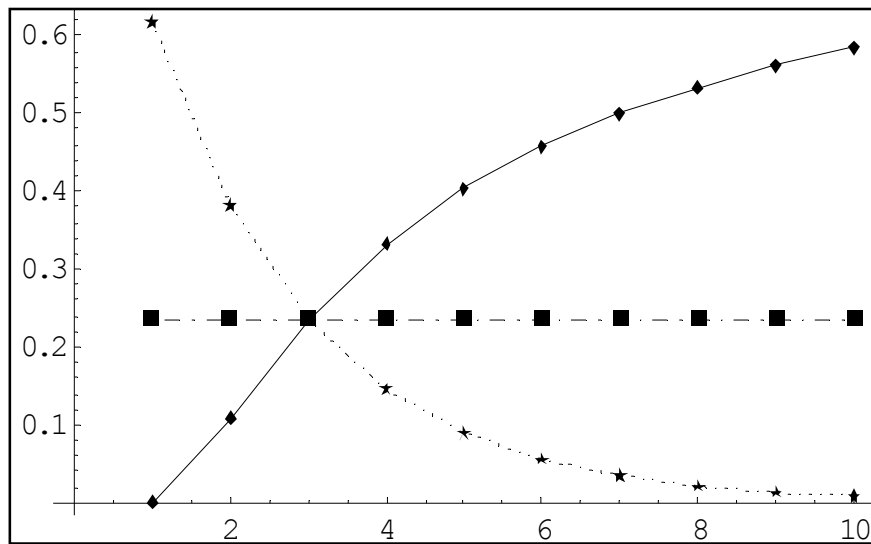

Fig: Third Order Damping Constraint

The dotted curve shows powers of 0.618.

$A_n := 1 - \frac{1}{n}$ $B_n := 1 + \frac{1}{n}$	
$\left[ \frac{\sqrt{(A_n)^2 + (B_n)^2}}{B_n} - 1 \right] \cdot 2$	$\left[ \frac{[\sqrt{1 + (2)^2}] - 1}{2} \right]^n$
0	0.6180339887
0.1081851068	0.3819660113
0.2360679775	0.2360679775
0.3323807579	0.1458980338
0.4037008503	0.0901699437
0.4578072192	0.05572809
0.5	0.0344418537
0.5337231669	0.0212862363
0.561249695	0.0131556175
0.5841218916	0.0081306188

Secret Of Sankhya: Acme Of Scientific Unification.

The third order damping constraint is shown as the outcome of self-similar interactions. The number of nodes in a length can be counted but the number of waveforms in a node cannot be counted. If there are a number of sequential events  $\left(\frac{Kx}{c^3}\right) - (my \cdot c^3) = 0$  it can be counted but the simultaneous within the sequential period can not be determined. All simultaneous interactions s, density, inertia etc.

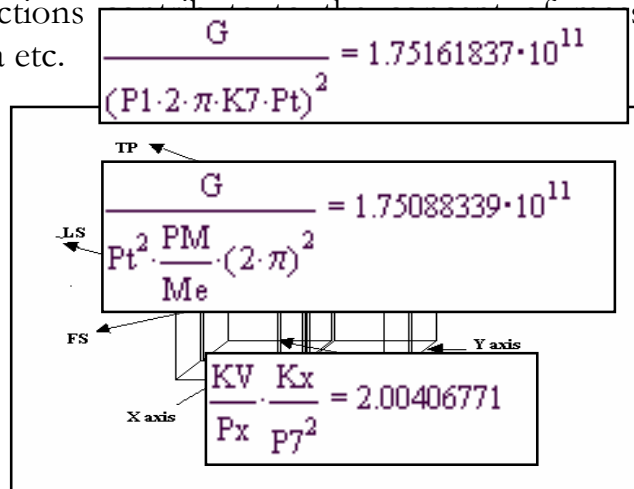

Fig: Concept Of Vortex As Vrithi

stress curves along all three axis in asynchronous state outside the central coheent state. The curves at the central position have an cyclic period interval less than  $1/ 5e+13$  and therefore present continoues field of stress values.

Because





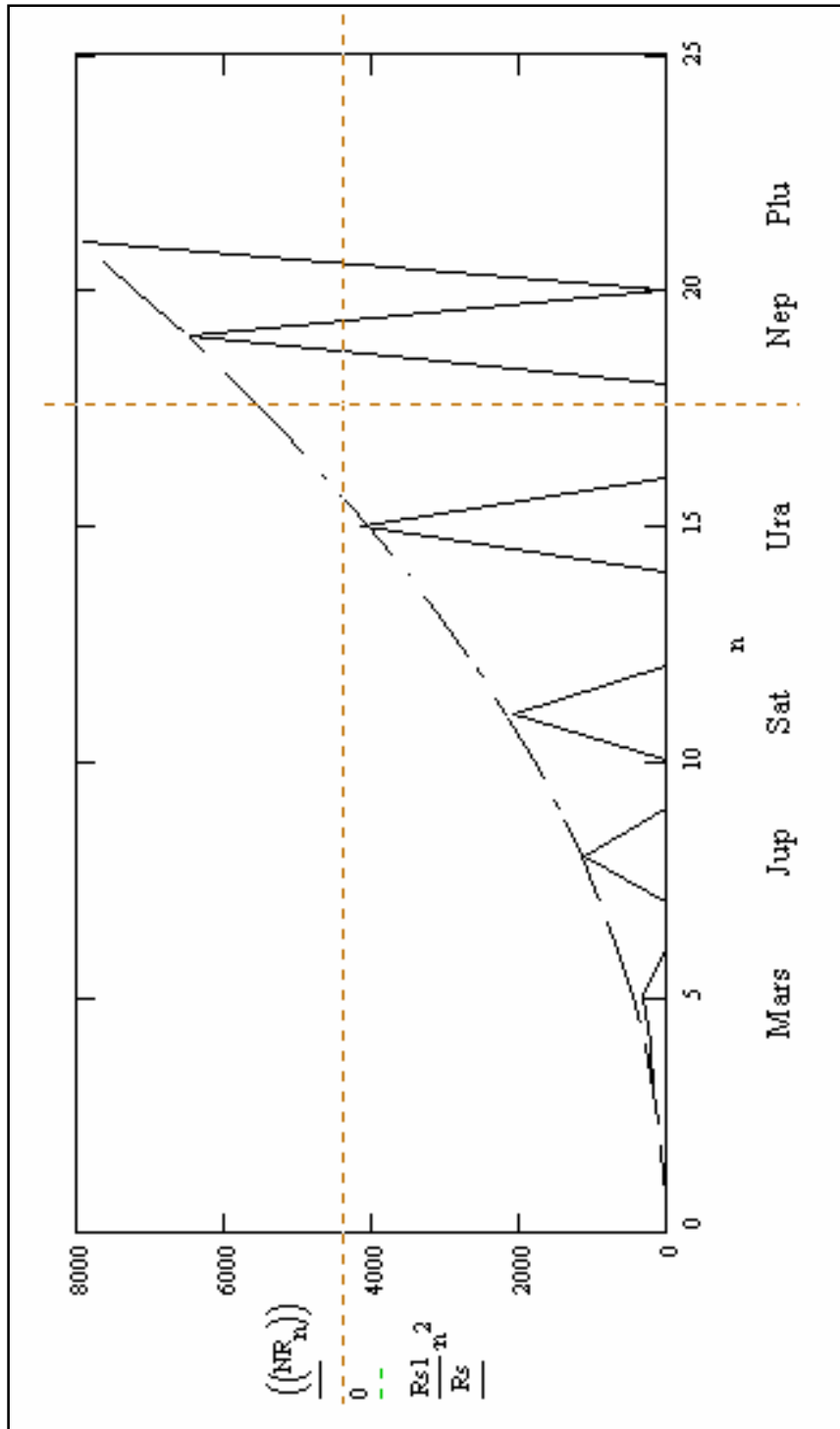
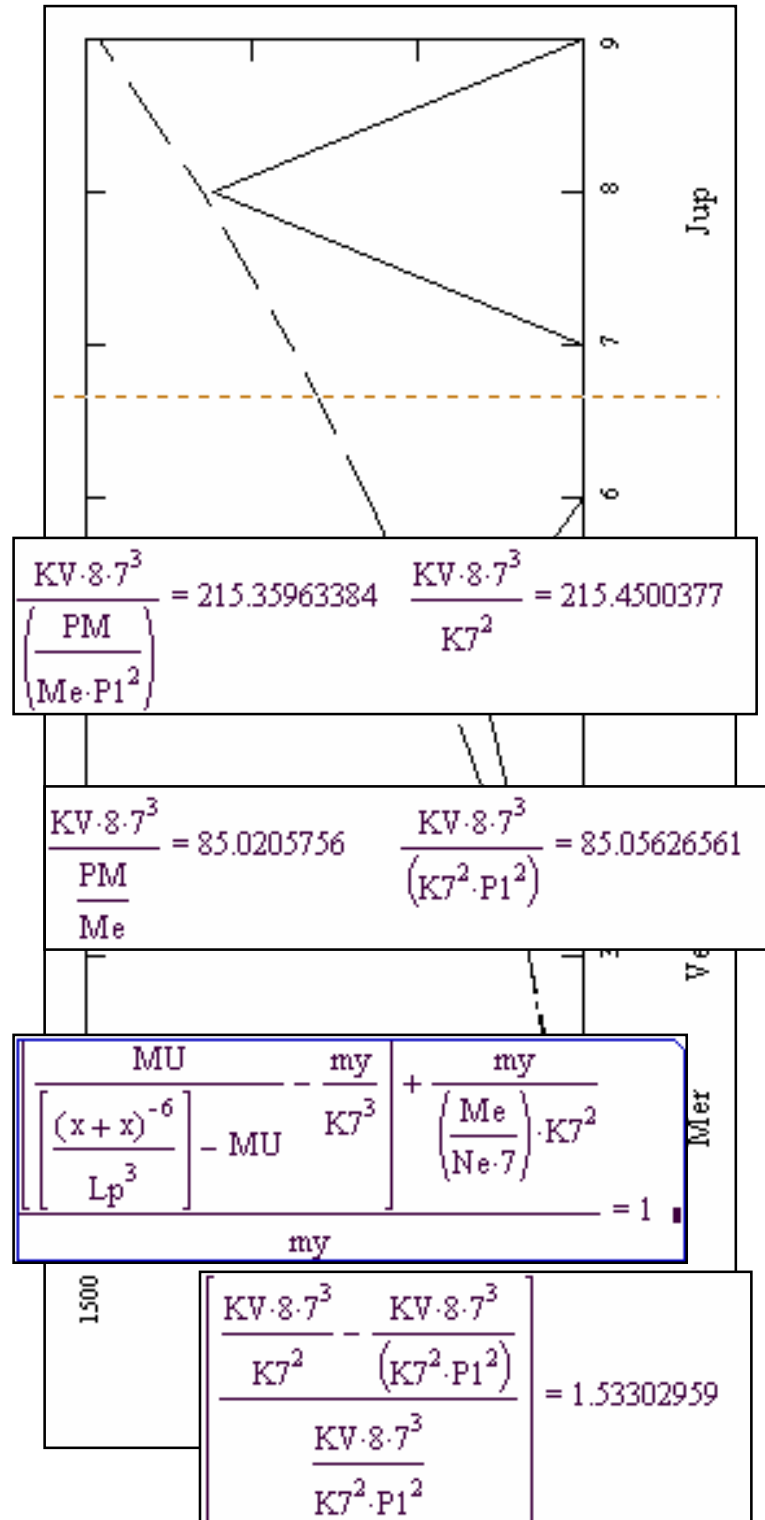

Fig: Axiomatic Orbit Of Major Planets.

Secret Of Sankhya: Acme Of Scientific Unification.

Fig: Axiomatic Orbit Of Minor Planets.



Power House Of The Universe.

In order to make the derivation transparent the Sankhya axiomatic method is used. Hence no external or empirical values will be used. The process of dividing space by 2 keeps the central point in the same location.

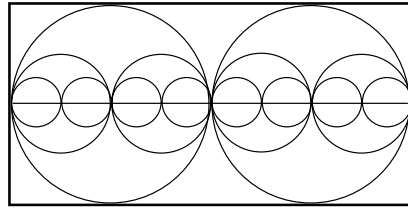

Fig: Centre Of Resonance

Sequentially dividing by two keeps the central point in the same location where all the lines pass through and form a node of density proportional to the number divisions made. The nodes are cubic domains of permanent certainty whereas the intermediate regions contain changing flux and acceleration parameters. Numerical accuracy in this region is dependant on specifying at least two related parameters.

Hence, the numerical ratio of cubic space is  $\frac{1}{2^3}$  or  $\frac{1}{8}$ . If the cubic values of all subsequent sequence of such divisions are added up it will equal  $\frac{1}{7}$  as the spectral states, shown below

EP1 
$$\sum_n \left(\frac{1}{2^3}\right)^n = 0.142857 \blacksquare$$

The difference in value between the cubic unit and the next expanded cubic form is  $2^3 - 1^3 = 7..$

411 
$$\frac{\sum_n \left(\frac{1}{2^3}\right)^n + (2^3 - 1)}{2^3 - 1} = 1.020408$$

EP2

Adding the sum of divisions to the difference due to expansion and dividing by 7 gives the ratio of expansion from unit 1 to 2, as the radiant rings of resonant states extending to infinity as  $RS = 1.02040816$ . The cyclic count as shown earlier is 10. Self-similar expansion as derived earlier is  $1+x$  and the compression is  $1-x$ . Hence the self similar ratio of an expansive interactive potential is  $10^2 / 10^{1-x} = 10^{1+x}$  or  $10^{1/x}$ . The value of the cube root of 2 = k and  $2^3 = k^9$ . Therefore the ratio of simultaneous interaction  $2^3$  in the period k is  $k^{9-1} = k^8$ . The sequential rate is 7 or  $(k^9 - 1 = 7)$ . The ratio of simultaneous expansion to sequential expansion rate per cycle of 7 is:

EP3

$$\frac{\frac{1}{10^x}}{k^{9-1} \cdot (k^9 - 1)} = 0.933661 \quad \blacksquare$$

The ratio EP2 represents a centred or stationary state containing rings of resonant counts and EP3 depicts the ratio of expansive change to sequential change in the same cyclic interval of 7. The comparative rate of change shown below in EP4 of these two dynamic ratios of change in a stationary state defines the change within a change or the accelerative mode of change but is centred & static.

EP4

$$\frac{\frac{1}{10^x}}{k^8} \cdot \left[ \sum_n \left( \frac{1}{2^3} \right)^n \right] \cdot \frac{2^3 - 1}{\sum_n \left( \frac{1}{2^3} \right)^n + (2^3 - 1)} = 0.914988$$

## Secret Of Sankhya: Acme Of Scientific Unification.

The Sankhya definition of EP4 in Suthra 3 is the Purusha state.as  $K_x = 0.91499$  counts/cycle. It represents the combination of Thaama, Raja and Sathwa states with the Lingaa Bhaava interface in EP3 and the Abhimaan-Ahankaar crossover point as EP2. All these phases remain as though in a stationary state of coherent activity or a holographic state of frozen activity and is described as the Andhathaamishraa or blackhole state of unmanifest activity. The Purusha of value  $K_x$  is a fundamental state where all activities come to a restful state of coherent activity. The proof lies in the value of the Catalan, the sum of all odd or non-synchronous states as follows:

$$\text{CAT} := \sum_j (-1)^j \cdot (2 \cdot j + 1)^{-2} + 1 = 0.915977847$$

The simultaneous division of two as an endless power series represents the resonant but static state summing up to a total of  $1/7$  in EP1. The cubic coherent state represents the equal rate of activity along all three axis. It is a synchronised count rate wherein the cubic count rate of  $C^3$  reduces to  $C$  because the counts along the two axis remain in step. That is if ten people clap individually ten counts are possible but if all ten clap simultaneously, in lock step or in absolute synchrony only one clap will be heard. In the same way if vibratory or oscillatory interactive counts act exactly in phase along all three axis then the count rate will be only the value along any one axis. But the same rate will be counted in all three directions and represents a simultaneous surface of activity or a spherical wave front of vibrations. The point at which counts along two axis synchronise is when the rate of self similar expansion reaches the maximum  $C^{1+x} = 5.1e10^{13}$  and the cyclic interval becomes a minimum ..

The cycle is a sum of changes that reach the original state after a sequence of interactions. Its derivation and proof

Secret Of Sankhya: Acme Of Scientific Unification.

have been given in earlier Suthras. In the very first gradient or ratio of cyclic period difference in an interaction is 1 to 2 and the deviation or the difference in displacement causing non synchrony is as follows

$$\text{EP5} \quad \frac{2}{\sqrt{1+2^2-2}} = 8.472135955 \quad \frac{2}{x^3} = 8.472135955$$

The ratio EP5 is a simultaneous self similar ratio and as it's a cubic ratio of x it has the limiting property or damping force to maintain an oscillatory state perpetually. Its numerical value as a cyclic process will be C as counts per cycle: All numerical values are given precisely as there is no uncertainty in Sankhya logic

$$\text{EP6} \quad C := 10^{8.472135955} = 2.9657596692 \cdot 10^8$$

The count rate of C per cycle of ten counts represents the internal rate of oscillations maintained perpetually as long as there is no externalisation or radiation of internal activity counts. This is ensured by two factors . As long the resonant division by 2 is not disturbed the centred state remains. Next, even if the centring action is disturbed, as long as the accelerative rate of change does no exceed 1+x the ability to regain the original state is ensured by the third order damping force or the x<sup>3</sup> factor that opposes prolongation of internal cyclic period as x-x<sup>2</sup> = x<sup>3</sup> . C equals the measured value of velocity of light minus a correction for the velocity for the Milkyway Galaxy through space. As explained earlier there is a Doppler shift due to Galactic velocity and that correction is Fc = 1.08045 of a cyclic time which gives the velocity of light as derived

$$C \cdot fc = 2.997925 \cdot 10^8 \cdot \frac{\text{m}}{\text{sec}}$$

Just as 2<sup>3</sup> represented the resonant and centred cubic state C<sup>3</sup> represents the same simultaneous internal activity state.

Secret Of Sankhya: Acme Of Scientific Unification.

Further as shown earlier the sequential activity within a cycle of ten counts is contained within  $\square\square$ , because the displacement is proportional to  $x$ , the self similar ratio. Hence any simultaneous colliding or instant interaction between two such states is  $C^{3*2} = C^6$ . Not more than two states can act simultaneously to equal  $C^6$ . The EP5 ratio of  $Kx$  being the ultimate state of coherent activity then the ratio  $Kx / C^6$  gives the Moolaprakrithi or  $My$  the smallest cycle or the shortest possible count per interaction.

$$My := \frac{Kx}{C^6} = 1.3446202249 \cdot 10^{-51}$$

The ratio of the coherent resonant state in EP2 extends to infinity as rings of resonance that remains in coherent state till disturbed by any non synchronous activity. The proportion of counts in the resonant spectrum will be EP2 less 1. Hence the value of resonant counts in terms  $My$  in the Satwic region of the radiant spectrum is

The astronomical value arrived at is in a potential state and only a disruptive activity will trigger the coherent state into a decaying resonant activity to regain the balance. As shown earlier the  $My$  counts are equivalent to Plancks energy per frequency constant in quantum physics. Hence EP8 is the equivalent of the energy resident in the fundamental field of space as a coherent unmanifest activity that has not become radiant till

$$EP8 \quad my \cdot \left[ \frac{\sum_n \left( \frac{1}{2^3} \right)^n + (2^3 - 1)}{2^3 - 1} \right] - 1 = 3.334355 \cdot 10^{52}$$

## Secret Of Sankhya: Acme Of Scientific Unification.

disturbed. It is the state before the field appears in quantum physics. The reason for the inability to detecting the basic field in Physics is that there exists no experimental way of measuring the potential or coherent state of dynamic activity. Unless motion is detected instrumental confirmation is not possible as any instrument detects only a change in its state. For a change in potential to be detected the initiation of an accelerative motion or force is needed to trigger the detecting instrument to change in some proportion.

The equivalent rate of energy or power is resident in the Planckmass in a state of rest. In other words its mass and energy are in the same state or the same numerical value. It is the equivalent of entropy of a system at rest. But the scientific habit of looking at mass and energy as different fundamental traits hides this difference. Reviewing Mass is synchronised or coherent vibrations that superposes the vibratory count along two other axis to give the same count. Hence  $C^2$  disappears from the countable spectrum When not synchronised the  $C^2$  aspects becomes a detectable factor with a time element The point at which two vibratory counts synchronise perfectly is at  $C^{1+x}$  counts. For C cannot expand in a self-similar manner beyond that value. The vanishing of a value is a real process of synchronisation along two axis.

Planckmass and Plancktime value is shown below

$$\sqrt{\frac{C}{G}} \cdot (h) = 2.176635 \cdot 10^{-8} \cdot \text{mass} \quad \blacksquare$$

$$\sqrt{\frac{h \cdot G}{C^5}} = 5.390693 \cdot 10^{-44} \cdot \text{time} \quad \blacksquare$$

The maximum power or energy/time that can be generated is:



Secret Of Sankhya: Acme Of Scientific Unification.

$$\text{EP9} \left[ \sqrt{\frac{C}{G} \cdot (h) \cdot C^2} \right] \cdot \sqrt{\frac{C^5}{h \cdot G}} = 3.628962 \cdot 10^{52} \cdot \text{time}^{-1} \cdot \text{joule}$$

Here the conceptual difference between Quantum physics and Sankhya logic becomes at once evident. The axiomatic EP8 value is the same as the (after correcting for time) rest mass energy of the Planckmass per Plancktime or the rate of power that could be developed in the substratum. The enigma why there are Planckian fluctuations in space is answered once it is clear that space is a dynamic field of components that cannot be detected unless it moves. The Mahad or Planck mass is a dynamic perpetual self similar oscillator operating at exactly C cycles per cycle (or second) and that equivalence to EP3 is shown below. It will prove that interface between Thaama and Raja or the Strong / Weak force interactive domain is the cause of the planckmass to neutron (quark to hadron) transition in time varying cycle that does not radiate any energy. Hence it is not detectable till a violation of the coherent state occurs resulting in many types interactive transitions. The equivalent axiomatic Mahad Prakriti mass in Sankhya has already been derived above as. Mps counts/cycle.

$$\left( \text{Planckmass} \right) \cdot \frac{C}{7} = 0.932198$$

$$\frac{\text{Mps} \cdot c}{7} = 0.933661 \quad \blacksquare$$

$$\left[ \frac{\sum_n \left( \frac{1}{2^3} \right)^n + (2^3 - 1)}{2^3 - 1} \right] \cdot K_x = 0.933661$$

Secret Of Sankhya: Acme Of Scientific Unification.

EP3 =

$$\frac{10^x}{k^{8.7}} = 0.933661 \quad \blacksquare$$

EP3 is the combined ratios of the rates of interaction at the interface . It takes place simultaneously within the cycle and internally balances all the parameters through self similar exchange. The centred Thaama or the static blackhole state as  $k^8$  and the resonant Raja shuttling state as 7 and the Sathwa expansive state as  $10^{1+x}$  interact simultaneously to maintain the balance between the Purusha blackhole  $Kx$  value and the expanding Mahad Mps value by C.

If for any reason there is unbalance then Mps transforms into the time cycle oriented resonant state by the factor RS. The period of change RS-1 releases the count value of EP8. Its equivalence to EP9 which is a ratio of Planck-mass.energy to Plancktime is a unequivocal confirmation that the substratum of space fluctuates in period RS-1 to regain its internal oscillatory balance.

EP10

$$\begin{aligned} & \frac{1}{(\text{Plancktime} \cdot (\text{RS} - 1))^3} \cdot k = 1.300647 \cdot 10^{-15} \\ & \frac{1}{(\text{Sankhyatime} \cdot (\text{RS} - 1))^3} \cdot k = 1.324821 \cdot 10^{-15} \end{aligned}$$

It is further confirmed by an outstanding equivalence to the nuclear Compton wavelength when expanding by k to twice the cubic state, as shown in EP10.

The Prakrith Saptha or PM the Nuclear (Hadron) state is

EP11

$$\left( \frac{2 \cdot \pi}{10 \cdot \sqrt{3} \cdot c} \right)^3 \cdot Kx = 1.674423 \cdot 10^{-27} \quad \blacksquare$$

Secret Of Sankhya: Acme Of Scientific Unification.

PM as derived above provides further confirmation that the Compton wavelength exists at this boundary. Since Physics uses the energy concept to balance, whereas Sankhya uses only the delay in time cycle as an indicator of inertia, both methods will be shown to produce the same results.

$$\frac{h}{P_m \cdot C} = 1.321347 \cdot 10^{-15}$$

$$\left[ \frac{PM}{(Pd)} \right]^{\frac{1}{3}} \cdot (k - 1) = 1.322754 \cdot 10^{-15} \quad \blacksquare$$

While the energy expression using Planck's constant hides the actual physical status, the Sankhyan process shows the Pd is the density of space in the expanded (due to loss of potential) but still in a coherent state. The Compton wavelength commences only beyond the boundary the ratio  $2^{1/3} - 1 = 0.2599$ . That is the difference  $(k - 1)$  is the place where the first resonant state can exist when coherence is destroyed. It is an axiomatic fact. Hence it needs no proof.

The above comparisons confirm at a glance the nature of the Mahad or Planckmass function in space.  $Ep^3$  is an axiomatic function at 1 count / cycle and yet the Mahad characteristics equal the same ratio of interaction at C counts/cycle. The Purusha function  $Kx$  at EP2 again equals the same ratio. This is an axiomatic or visual proof of the equivalence of these states at different cyclic levels. It shows the potential level difference in three changed states without any detectable interactive reaction. This method of proof at a glance is the only way to show the identical nature of the three states of coherent potentials. Because there is no equivalent equation in physics dealing with simultaneous domains where only the potential is

## Secret Of Sankhya: Acme Of Scientific Unification.

derived axiomatically. In Figure 15 the relative relationship in physics is displayed, based on count number. The count  $C$  has been axiomatically derived and its cubic value is the normal stable count / cycle in three dimensional space. If an interaction takes place between two units in a cycle the count value rises to a maximum of  $C^6$ . If the count  $C$  along each axis interacts with its opposite axis then the six directions will also give  $C^6$  counts at the interacting point in the centre. The maximum  $C^6$  counts do not take place in one cycle but  $Kx$  is value of the maximum delay or inertia or mass. The minimum or smallest fraction of delay is  $My = Kx/C^6$ . Hence all interactive counts can be presented as a product of  $My$  into interactive counts, in a dimensionless way with  $Kx$  being the maximum and  $My$  the minimum. If  $C$  is the count value of the self-similar, harmonic, perpetual, fundamental, oscillator in elemental space populated by a sea of identical components of whatever description, then in terms of count there can be no greater value than  $Kx$  per cycle and no smaller value than  $My$  per cycle. The counts of interactions along any axis can be cubed to set the maximum coherent count rate possible in that state. Similarly the cube root of the the same count establishes the stationery or static count value and that gives maximum number of field points or stationray elements that con exist along the that axis. Hence the cubic count divided by the cube root count specifies the self similar or scale invariant population of field points within the cubic volume. The foregoing statement lays the foundation for all physics or all the sciences. It applies to any scale as it is scale invariant. Sankhya has shown the potential ladder as  $10$  raised to an index

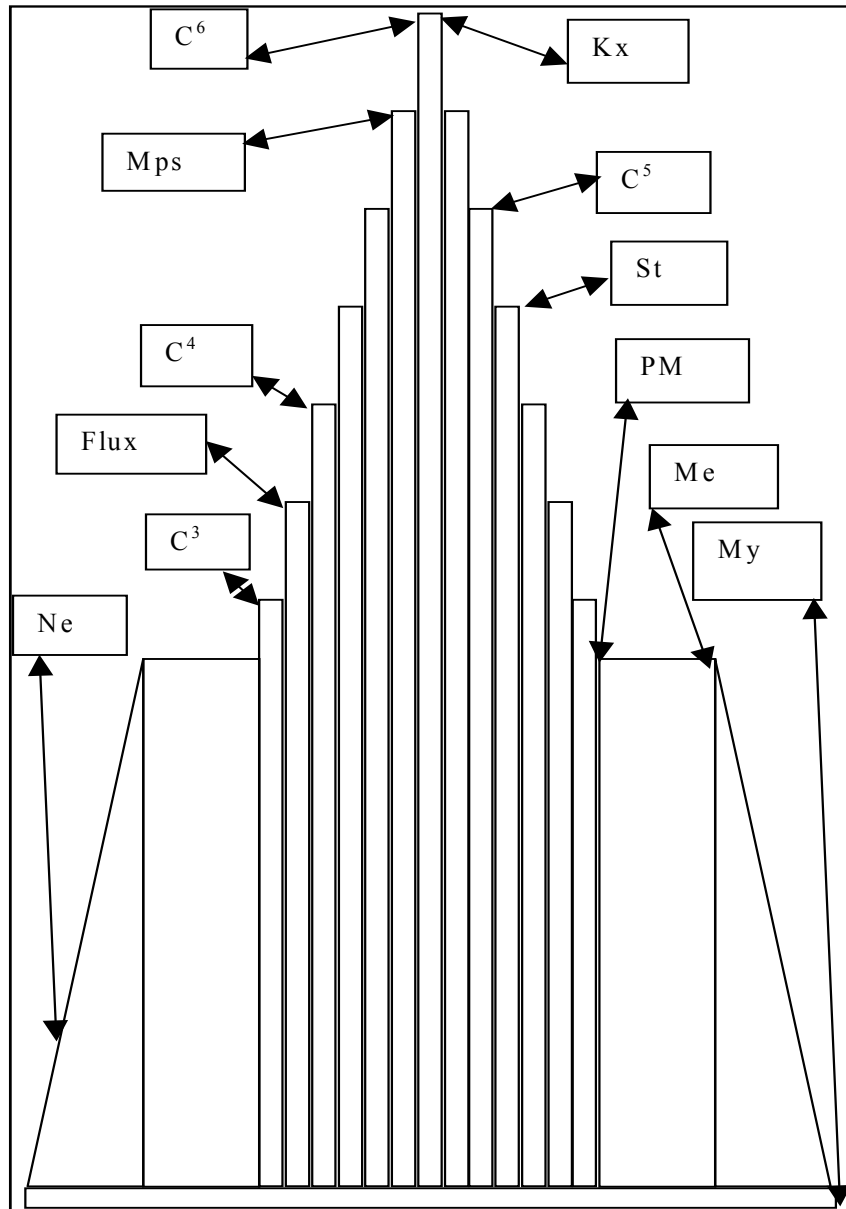

Fig: Cosmic Power Structure

number in the most elegant manner, leaving the numerical precision to be adjusted by dimensional correction if desired. Hence the values are shown as equivalent to dimensional physics.

The conversion of My or Kx to the mass value in physics can be carried out by setting the velocity of light in physics  
421

Secret Of Sankhya: Acme Of Scientific Unification.

to a seconf of  $fc=1.010845$  cycle in Kg/metre/sec. The Planck's constant  $h$  is:  $[My C^2 (4 \pi^2 / 7)]$ .

$$EP12 \quad \boxed{My \cdot (4.927785 \cdot 10^{17}) = 6.626 \cdot 10^{-34} = h}$$

The interactive count value along any axis is  $C \times C = C^2$ . If similar counts along the two other axis take place within the same cycle then the total count value =  $(C^2)^3 = C^6 /$  cycle. Similarly if two cubic units of space interact the total count =  $C^6 /$  cycle. The total time taken for  $C$  interactions at the minimum cyclic time of  $My$  will be  $My \times C \times EP1$  ( $EP1$  is the sum of the total increment from its static value). Also the increment on expanding by 2 units along each axis equals 8 mines 1= 7. Therefore the shortest time for  $C$  counts is:in fact equal to  $T_p =$  Placktime (when corrected)

The smallest delay per cycle  $My$  times  $C$  will give the shortest time period of ten counts that equals the second approximately.

$$EP12 \quad T_p = \left( \frac{c \cdot My}{7} \right) = 5.696886 \cdot 10^{-44} \quad \blacksquare$$

The Purusha blackhole state of  $Kx$  reduces to the Mahad value of  $Mps$  (Planckmass) when its coherent and synchronised state on all three axis is broken by  $C$ . The cyclic time taken extends from  $My$  to  $T_p$  ( $EP12$ ) as a stable centred and synchronised state in a complete cycle of  $C$  counts has been reduced. In the previous section the axiomatic derivation of numerous modes of constructing the Mahad state was shown . Reducing the  $Mps$  stable value as a ratio per cyclic time  $T_p$  gives the rate of change of counts per cyclic time as  $St$  the dynamic stress in the substratum. Since  $Kx$  was coherent, only after the break in synchrony by  $C$  in time  $T_p$ , can it produce the rate of change per time cycle as  $St$ . or the stress in the substratum:

Secret Of Sankhya: Acme Of Scientific Unification.

EP13

$$\text{St} := \left( \frac{\text{Mps}}{\text{Tp}} \right) = 3.868244 \cdot 10^{35}$$

$$\frac{\text{C}^3}{\text{G1}} = 4.037765 \cdot 10^{35}$$

The equivalence of St to the lower  $\text{C}^3 / \text{G1}$  as the metric elasticity of space identified by Sakharov, Chandrashekar and others gives support the qualities of the field in space.

EP14

$$\frac{\text{C}^2}{\text{charge\_ec} \cdot \sqrt{2}} = 3.96654 \cdot 10^{35}$$

St is the value of an electronvolt of change in mass energy units as shown.

The next stable state reached after a loss of one more cycle of C counts results in the the breaking down of the simultaneous state to produce the synchronised count along two axis. So far the interactions in the substratum was an internal simultaneous exchange which did not propagate any counts outside its boundary of action. Here the comencement is signaled by a distance parameter as  $L_p$ .

EP15

$$L_p := c \cdot \text{Tp} = 1.68956 \cdot 10^{-35}$$

$$\text{Flux} := \left( \frac{\text{Mps}}{\text{Tp} \cdot c} \right) = 1.304301 \cdot 10^{27}$$

The term  $L_p$  is the equivalent of a length if C is specified in metres wavelength / second and is equal to the Plancklength. The stress in the substratum of space is C times Flux EP15. That count rate of the flux per cycle is 423

## Secret Of Sankhya: Acme Of Scientific Unification.

due to the self-similar nature of an expansive interaction in a contained field of space. This value is critical and must be interpreted correctly. When oscillatory wave counts are identical along two axis the density rises but the counts reduce to that of one axis. If counts along x and y axis differ the product of both values can be counted as events. But if they synchronise perfectly then the count reduces to that on any one axis but the count become rings or circles of counts. The Lissajou figures below show the coherent ring when  $n_1 = n_2$  are equal or reflect simultaneous activity but

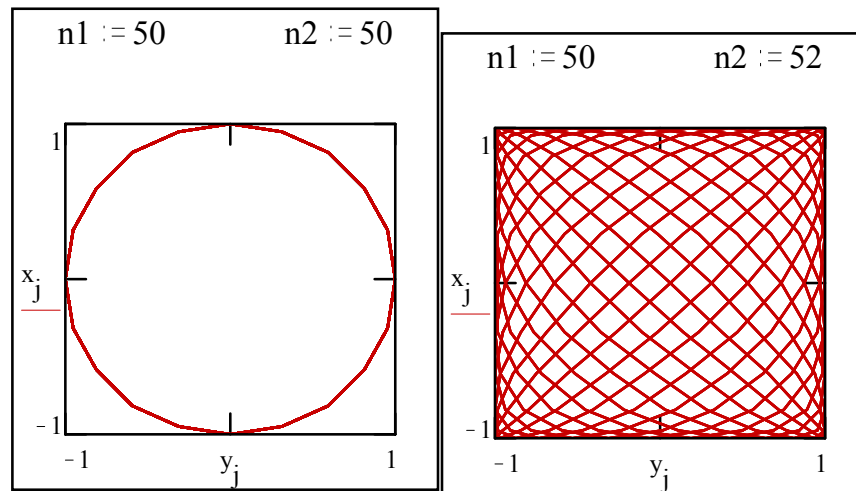

Fig: Lissajou Figures Show Coherence

when there are more than one count difference the coherent pattern breaks up and increases the interactive count. . In the same way when the count of  $C$  is identical along all three axis the the  $C^3$  count falls into step and the value of counts reduce to  $C$  thereby hiding  $C^2$  as a factor that increases the density and displays mass characteristics. Coherence produces spherical or circular time period functions or rings of simultaneous interactions and hides the true numbers involved.

When interactions take place along one axis from opposite ends the total value is  $C^2$  . But the self similar internal characteristics allows simultaneous exchanges between



## Secret Of Sankhya: Acme Of Scientific Unification.

compressive and expansive states to vary the proportions according to the Guna laws explained in the relevant sections.. The compressive value can raise the count value to a maximum of  $C^{1+x}$  while reducing the expansive value to a minimum of  $C^{1-x}$  at the same time. Hence the smallest interval beyond which counts along two axis can act simultaneously, like the Lissajou patterns with equal counts, is  $1/C^{1+x}$  Hence till the point of reaching the synchronised state the flexibility or slackness or elasticity is displayed but when the difference is nil the  $C^{1+x}$  raises as the square or cube depending on two or three axis synchrony. Hence at the Flux of value of  $(C^{1+x})^2$  the density of interactive counts increases suddenly to create additional mass characteristics.

The Thaama state represents the quark domain in particle physics. It is the strong force domain in asymptotic freedom. The Raja domain is the weak force region. The EP3 ratio is the equivalent coupling constant that varies with potential change, enabling transitions in the strong-hadronic / weak - interface. The Sathwa domain is the electromagnetic region. The EP2 ratio is the equivalent of the coupling constant enabling transitions from radiant-photon-electromagnetic/weak-leptonic interface. Unlike in physics the Sankhya spectrum is a continuous state of transitions that are coupled by the EP3 and EP2 ratios that demarcate a phase change of two axis and three axis synchrony when energy to mass transition takes place. The above is a brief outline of the parallel transport in particle physics and can be justified perfectly by a few conceptual changes. However, the Sankhya logic being logically superior, it explains the power generation process in the substratum perfectly and the following will cover the further sequences in the Sankhya process

The oscillatory state in the substratum of space is kept in a coherent and synchronised state by the internal exchange of oscillatory counts between the Purusha and Mahad

Secret Of Sankhya: Acme Of Scientific Unification.

Prakriti's Linga potential variation balanced simultaneously by the Mahad.Prakriti's and Prakriti.sapta form or Bhava variations as a totally internal count transfer, represented by the EP1 to EP4 type of mechanism.

In the Fig. 'Ladder of Phenomenon' the order of logical flow of phenomenon is shown.to highlight mathematical rigour of the derivation of each state (again) as a sequence of steps. The comparative equivalence can be seen at a glance. Sankhya conceptual logic shows that the Universe follows an extremely orderly process. The ladder of phenomenal action starting from 1 unit that indicates a relatively stable or equal state of activity rises to its axiomatic axiom of  $C^6$  value. The basic principle of self similarity in action or Swabhava mode creates stress according to Suthra 55 The same principle derives the fundamental state of stable action. As all the parameters shown above have already been derived in earlier sections it will be used to explain the process of achieving perfect balance in the entire scale of phenomenon.

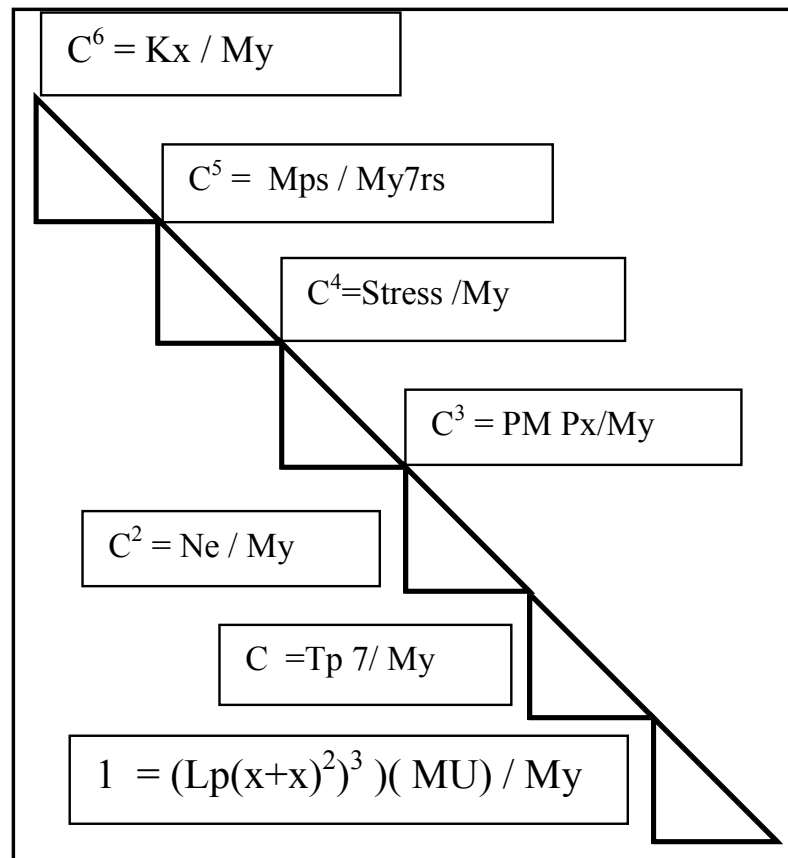

Fig: The Ladder Of Phenomenon.

The maximum interactive count value of the Universe is MU.and the corresponding minimum is My. The MU/My ratio must always equal the ratio of astandard cyclic cubic space expresses as an axiomatic value to its changing cubic space within the same cycle. The first or primary interaction when cyclic time and incremental space are equal is  $1+x = 1/x$ . The interactive increment rate and time cycle at resonance is  $(1+x)/2$  and  $1/2x$ . Therefore the displacement will be its product just as  $Lp = C Tp$ .(that is rate of displacement into time =total displacement.)

$$\left(\frac{1+x}{2} \cdot \frac{1}{x \cdot 2}\right)^3 = 0.2803792486 \quad (C \cdot Tp)^3 = 4.823036270410^{-105}$$

$$\frac{\left(\frac{1+x}{2} \cdot \frac{1}{x \cdot 2}\right)^3}{(C \cdot Tp)^3} = 5.813334855310^{103} \quad \frac{MU}{My} = 5.813626619110^{103}$$

The identical equivalence can be seen in the two ratios. Moreover an extraordinary proof comes by way of confirming the frequency (cps) of the socalled Lamb shift at the fundamental level as

$$LAMBSHIFTIN = \frac{c}{\left[\left(\frac{Ne \cdot c}{c^3 \cdot my}\right)^2\right]^3} = 1.057767179310^9$$

427

$$LAMBSHIFTOUT = \frac{c}{\left[\left[\frac{Ne \cdot c}{c^3 \cdot my} \cdot \left(\frac{10}{2 \cdot \pi}\right)^2\right]^2\right]^3} = 4.004501934310^6$$

Secret Of Sankhya: Acme Of Scientific Unification.

Another proof is given by comparing the sum of all the interactions in the Universe at any instant or period  $T_p$  to the maximum number of interactions in a cycle.as:

$$\frac{t_p}{\sum_n \left(\frac{1}{8}\right)^n} = 3.98782043710^{-43}$$

$$c \cdot m_y = 3.987820433310^{-43}$$

Again the exact equivalence gives startling proof of the perfect logic Sankhya has used in understanding phenomenon. The  $L_p$  is the equivalent of the Planck length in Quantum theory and  $M_y$  is the mass value of the Plancks energy constant 'h'. Hence the source value of 1 is perfectly justified. The rest of the incremental steps. In the potential as  $C$  to  $C^6$  are equated to stable states whose derivations have been shown earlier. Reiterating the states,  $L_p$  is the smallest displacement along any axis and  $T_p$  is the smallest fraction of a cyclic time.

$$\left(\frac{Ne \cdot C}{PM \cdot P_x}\right) = 0.8056819919 \quad \left(\frac{2 \cdot \pi}{7}\right)^2 = 0.8056819919$$

The Vikrithi state  $Ne$  is the flux of interactive counts transmigrating constantly at rate  $C$  to keep the balance. The equivalence shows the ratio of incremental displacements to cyclic or angular changes in position in the coherent state of Prakrithi as  $PM$  the nuclear or Hadronic state.  $P_x$  is the super-positioning density due to

428

Secret Of Sankhya: Acme Of Scientific Unification.

the interactions taking place in the same location or the coherent state. The  $(PM \ P_x)/M_y = (C^3)$  or the  $(PM*P_x)/K_x = C^3$  state is a stable and isolated interactive self-similar domain that does not radiate or exchange counts. For the maximum  $K_x$  and minimum  $M_y$  keep it at constant  $C^3$ , the real description of orthogonal space that is in a dynamic and holographic state. This is the Kaivalya description in Suthra 68 that states that the stress has diminished to such a fine level that space remains in totally synchronised oscillation at an axiomatic rate of  $C$  But because  $C^3$  is in a coherent state the detectable count rate will be only  $C$  along any axis as the other two axis are in total and **absolute** synchrony In this state  $C^2$  counts will not be detectable and therefore would seem to vanish. Recall the simultaneous clap episode or the Lissajou figures.

It has been shown in formula ??? that when the interval between any axis is less than  $1/C^{1+x}$  the two behave or act together or simultaneously. Therefore any disturbance interval between any two axis exceeds  $1/C^{1+x}$  the coherent state is broken down and the transmigration of stresses take place to initiate a variety of phenomenon as shown in EP1 onwards. Though only one reason has been shown there numerous other factors that also contribute to this coherent state breakdown phenomenon. For instance the nuclear state of  $PM$  though not detectable when submerged in the  $C^3$  coherent state , becomes detectable with certain characteristics. The detectable radius in physics is  $R_p$  and the Compton wavelength as shown in Ep10. The axiomatic confirmation is as follows:

$\frac{k - 1}{c^{1+x}} = 5.089059400610^{-15} \quad \frac{(k - 1)^2}{c^{1+x}} = 1.322753662410^{-15}$
---

Secret Of Sankhya: Acme Of Scientific Unification.

The factor (k-1) is relative radial expansion when expanding twice cubically. The radial value is still depicts the coherent boundary. When coherence breaks then (k-1) that was synchronised breaks into its time dependant value of (k-1)<sup>2</sup>

When the stress in the substratum rises suddenly due to any type of triggered or impulsive disturbance as derived in Suthra 37 the reactive changes take place simultaneously. At the basic cycle level the cyclic count of 10 rises as 10<sup>2</sup> at the nodal position at 1/2 displacement period in the self similar oscillatory rate. Hence the 1/2 nodal position is raised instantly or the My interval. The C<sup>3</sup> state too interacts to raise it to the maximum C<sup>6</sup> simultaneously.

The Mahad Vikrithi or the first harmonic of the Prakrithi or (the nuclear hadron) the Electron is derived by three independent modes that ensures its existence for a brief period in the same location. EP17 at Kx displays the centred mass value of the Electron expanding in period k. EP 17 shows a complex high

$$\left(\frac{1}{2}\right)^{(10^2)} \cdot k \cdot K_x = 9.09408763210^{-31}$$

$$\left(\frac{1 - \frac{2}{\sqrt{5}}}{\sqrt{5}}\right) \cdot (C^{1-x})^7 \cdot \sum_n \left(\frac{1}{2^3}\right)^n \cdot my = 9.092440296810^{-31}$$

$$n := 2 \quad \frac{C^3}{P_x} \cdot \left[ \frac{k-1}{7} \cdot (2^n \cdot A_n \cdot 2) \right]^2 \cdot My = 9.095333399710^{-31}$$

density or simultaneous exchange phenomenon that involves many parameters. It has been dealt with in EP???. But taking the superpositioning value of C<sup>1-x</sup> (the coupling constant) as an instantaneous interaction produces a reaction of C<sup>1+x</sup> as the compression value in the hidden C<sup>2</sup> 430

## Secret Of Sankhya: Acme Of Scientific Unification.

regime in the coherent  $C^3$  value that can be detected only as  $C$ . Hence if  $C^{1-x}$  is raised 7 times as ( $2^3 - 1 = 7$ ) due to sudden triggering then  $C^{1+x}$  too must react instantly by raising it 7 times too, which leads to the Planck density  $D_p$  shown in EP ????. Therefore every time a Vikrithi as an electron is produced a Mahad Mps as planckmass is also produced These are shown in EP?????. Therefore Sankhya establishes through Suthra 62 in very clear terms that nothing is produced bound or released as substantial particles but that the vibratory stress of value  $M_y$  transmigrate in various simultaneous lots to produce the so-called objects that are detected.

So the unequivocal conclusion that must be drawn from the above mathematics that the Mahad Vikrithi  $M_e$  as electron and Mahad Prakrithi  $M_p$  as planckmass are formed and decayed in its respective cyclic interval. Both are the two simultaneous sides of the same coin metaphorically speaking. What remains constantly in the substratum are the Prakrithi Saptah or the Neutron undetectable configuration at the central Linga/Bhava or Strong/weak interface balanced by the Vikrithi Saptah as the Neutrino at the Abhiman / Ahankar or the lepton / photon electromagnetic crossover point. But in the coherent state in space its presence cannot be detected not because it is not dynamically oscillating but because in an absolute coherent state all three axis synchronise so perfectly that a spinning spherical shell does not emit any wave or radiations at all. Suthra 30 defines this state as the fundamental position to which a third order damping constraint drives vibrations into its restful state. The Power House is perpetually active ever ready to take the load on instant demand. Understanding this sequence of actions can enable the extraction of undreamed of levels of power by merely triggering space with a probe of the smallest power but in the shortest time The road to that is ingenuity which again is ensured by the same mechanism

## Secret Of Sankhya: Acme Of Scientific Unification.

enacted in the human mind by the Siddhi process of Suthras 4,5 and 6. The axiomatic mathematical proof shown every where proves that Sankhya is truly inimitable and especially when it is realised that not a single, repeat not a single empirical input has gone into this theory.



Secret Of Sankhya: Acme Of Scientific Unification.

Astrology, Ayurveda, Parapsychology are  
Axiomatic

Space is dynamic and is in perpetual oscillation as proved in Suthras 67 and 68. The Vikrithi saptha state prior to the acceleration of a Vrithi or photon is in a resonant interactive state of C cps. The coherent potential state at the Linga / Bhava interface between the Thaama and Raja regions is balanced exactly by C number of Ne Vikrithis or Neutrinos that can transmigrate across the entire Raja Abhiman / Ahankar spectrum.

AP1.	$\frac{Kx}{c^3 \cdot Px \cdot K7^2} - Me \cdot (P7)^n$	$\frac{Kx}{c^3 \cdot Px \cdot K7^2} - Ne \cdot (P7)^n \cdot K7^3$
	Me	Ne
	1.42000831	$2.46650469 \cdot 10^3$
	1.29290841	-16.14225953
	1.15130837	$-2.782021 \cdot 10^3$

The transmigration rate of both the Mahad Vikrithi and saptha or the Electron Me and Neutrino Ne are changed by a correspondin interactive rate due to altered stress transmigration rates in the substratum. The interactive rates change whenever the synchronous balance is upset. The Me and Ne change here are time bound or sequential. It certainly affects the phase relationship of both Me and Ne states but do not constitute a current as it is not a 7-at-a-time Ne rate, shown below:

433	$\frac{Kx}{c^3 \cdot Px \cdot K7^2}$	AP2
	$Ne \cdot 7 \cdot (P7)^n \cdot K7^3$	
	0.15904897	
	0.14276203	
	0.12814289	

## Secret Of Sankhya: Acme Of Scientific Unification.

The interactive rate change of 3 levels have reversed (AP1) the Ne transmigration rate but as it does not exceed 7 Ne rate ( in AP2 --it is less than unity) in the transmigration rate, it cannot be detected . Nevertheless the PM/Me interface balance at the Linga /Bhave region (The weak EMG region in Physics) must respond by changing the phase of synchronisation. Particularly in genetic cells the innermost coupling boundaries will be most affected as the stress of confinement or bonding is greatest at that level. Subtle time oriented changes are initiated but the cause for which may not be evident. At the Abhiman / Ahankar interface the Ne drift in large numbers will create minor shift in potentials that if sustained will create observable changes. This is the Parapsychology interface for a whole range of ESP, Dream and Aura dependant phenomenon occurrences.

Unless such changes exceed the rate of seven Nes simultaneously no radiant or detectable phenomenon is set in motion. The planck constant is the equivalent of 7 simultaneous Ne changes, when the boundary of the second harmonic or the 8<sup>th</sup> unit level is exceeded. Such a rate is the largest possible change due to an interaction and will continue to transmigrate till the potential is reduced at  $10^{17}$  units distance or number of wavelengths for at each node a moolaprakrithi is absorbed to equalise the potential. Though mathematical logic has been shown at the simplest but relevant level , the mathematical expressions are complex as the number of simultaneous parameters involved are many. In Ayurveda and Astrology the critical phase relationship in a cycle is identified as sectors of 10 or twelve divisions within which the nature of the interactive events calssified through the permutations & combinations of the three Guna modes of interaction.

Secret Of Sankhya: Acme Of Scientific Unification.

While radiation of energy needs 7 Nes to be accelerated at the same instant or simultaneously, below that, any number of Ne's may transmigrate due to changing stresses without giving any clue to the underlying interactive process. Such tunneling activity create changes in phase in synchronised states that alter the potential. Dynamic and flexible molecular / cellular / genetic structures would undergo a twisting or unwinding stresses (without observable movements) through small angles that would tend to upset a balanced state. Living organisms would sense the change and react. Suthra 53 & 54 define the organic spectrum. These interactions are complex in nature and vary in time. Numerical evaluation of these changes can be made by iteratively to list the algebraic sum of  $x^n = 1$ . The interactive stress graph shown in fig. Stress Count Density below. Shows the planckian type of superpositioning of potential in internal timelike distribution as in blackbody radiation.

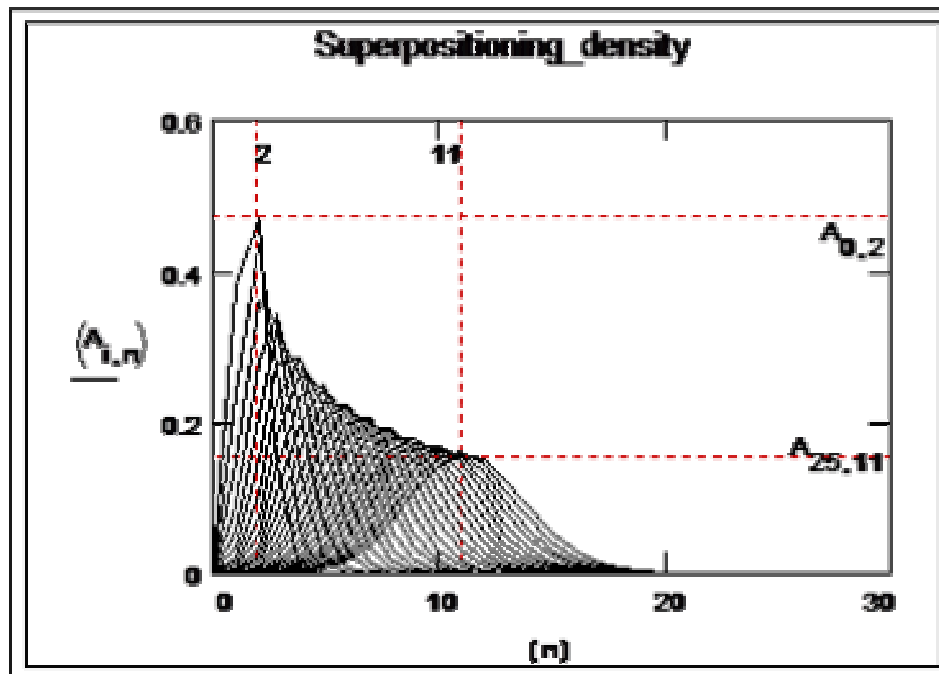

fig. Stress Count Density

## Secret Of Sankhya: Acme Of Scientific Unification.

The PM , Me and Ne states are synchronous and phase related. Hence changes in stress transmigration counts will effect its state that would correspond to changes in magnetic moment or gyromagnetic ratios besides affecting bonding or coupling values and interactive cross-sections. In the substratum these factors are standard ratios though it changes to complex forms in aggregated or compounded states. These are shown below.

$$\begin{array}{l}
 \text{PMm} = P_x^{\frac{1}{3}} = 2.75664448 \quad \text{Pnm} = 7^{\frac{1}{3}} = 1.91293118 \\
 \text{Mem} = \left(\frac{2 \cdot \pi}{7}\right)^2 \cdot \left(\frac{10}{2 \cdot \pi}\right)^2 = 2.04081633 \\
 \text{Nem} = \left(\frac{2 \cdot \pi}{7}\right)^2 = 0.80568199 \quad \text{Vr} = \left(\frac{2 \cdot \pi}{7}\right)^2 \cdot 7 = 5.63977394
 \end{array}$$

The ratios are PMm for the Prakrithi saptha or Proton & Pnm for the Neutron spectrum. Similarly Mem for the electron & Nem for the neutrino Vikrithi saptha spectrum. Vr for the radiating Vrithi or Photon spectrum, completes the change ratios along the entire Raja region covering both the Linga/Bhava and Abhiman/Ahankar interfaces. The organic spectrum is governed by a flexible Bhava disposition that retains the Linga coherent state. The angular division for a coherent state must have a ratio of  $\frac{1}{2}$  or 30 degrees. Axiomatically then a coherent structure with six or twelve divisions in a cycle would be required. Hence Carbon chemistry forms the base of organic states. Therefore astral stress transmigration that distort or twist this angular or hexagonal form only need to be studied. Astrological and Ayurvedic divisions are based on 12 sectors with 10 as the summation total following Sankhyan guna principle of self similar interactions. Hence 120 divisions are used to empirically

436

## Secret Of Sankhya: Acme Of Scientific Unification.

relate the twist due to stresses caused by planetary transits or configurations. The vernier effect of  $10-1=9$  gives the degree of overlap of adjacent angular dispositions. Hence Saturn's 30 yr cycle gives a repetitive confirmation of 3 or 4 observations whereas Uranus's 84 yr cycle does not offer even one cycle to derive meaningful interpretations. Also the degree of influence is less than a thousandth of the lunar/solar reference levels and empirical observations must be collated over long a period of at least 300 yrs to enable predictability.

As an illustrative example the closest orbits of Jupiter and Saturn cause a variation in gravitational acceleration on the earth of about  $1/30$  and  $1/850$  respectively. The Ne has the lowest ratio of turning moment and its rate of transmigration would be affected by such changes in some proportion. Though it may be small and undetectable as photons the duration over which such shift in potential exist are over relatively long periods. While the Vrithi or photon is the detectable messenger of communication, the hidden Ne streams are the communicators-in-plenty below that level. Just as Solar neutrino Ne streams cause visible and detectable differences through its interactions, the subtler planetary streams influence potential states which in turn affects atomic and molecular cell structures by the minute but consistent stress levels.. The changes are calculated as relative shifts in orientation that effect the coherent state, which is the normal one for the organism concerned.

The coherent divisions from the Andhathamisra regions gave 28 orders of counts that remained stable numerically. The 12 sector (30 deg.) gave the reference level for characteristics that added or subtracted from the three guna states and the transitions by the linga/bhava and the abhiman/ahankar polarisation factor. The 28 levels of change in descending order was characterised by the Nakshatra nomenclature in the Atharvaveda. Starting from  
437

## Secret Of Sankhya: Acme Of Scientific Unification.

the zero level ecliptic crossing called Punarvasu, when the organic form remained in its most felexible and balanced state, the list of 28 positions and its principle influence on the twelve sectors ware identified in the Nakshatradevatyam passages in the Atharvaveda.

It also laid the ratio of change by which the zero position of the ecliptic changed due to the precession of the equinoxes in about 25760 years. The original classification of genetic characteristics affected by the stress transmigration patterns were defined in the 28 nakshatra qualities. But as indicated in the Appendix 4: 'Age of the Vedas', the glacial melt causing a calamitous flood produced a resurrected version of the original Vedic oral creations by the survivors, which has led to misinterpreting the correct meaning. Of the 28 nakshatra positions, Abhijit's location (180 degrees from Punarvasu) along the ecliptic has now apparently disappeared due to the inclination of the earth's axis, thus making it difficult to accomodate its angular division in the current interpretive procedures. Hence post glacial astrology refers to only 27 nakshata positions, with the result the original interpretative meanings have drifted over to the adjacent bhavas or sectors. Astrological interpretation indicate trends of change in the genetic behaviour that may or may not aid the individual.

Ayurveda was based on the principle that stresses affected the characteristics of the biological field of the holographic body of all organic entities by influencing the combinatorial variations in the complex thaama, raja and sathwa state of balance. The classification of Vatha, Pithha and Khapha as being synonymous with sathwa, raja and thaama states was diagnosed through the vibratory state of the body. The degree of stress was inferred from the state of the pulse, which being the output of an interactive organic system, had to follow the same triad of guna laws. The state of the pulse was inferred by contact

438

## Secret Of Sankhya: Acme Of Scientific Unification.

and 3 positions with 3 possible variations in each of them led to 108 variants that were classified through empirical observation. The process could be likened to a technician observing waveforms on an oscilloscope. The balance of the three guna states in the body was interpreted in terms of the total energy in the body and not merely the externally observable conditions.

The guna principle of self similar interactions in the simultaneous mode, enabled the detection for an excess or lack of energy stored in the thaamasic or sathwic states as khapha or vatha characteristics, though the observable conditions of the body remained normal. The inference of such states through the variations in the pulse gave an early warning of impending disorders. While body temperature was an observable, the accumulation or depletion of energy as latent heat of cellular combinations did not reflect it as temperature variations. The biological field responded to fine stresses levels. Detecting such minute changes depended on observing changes from the normal state. The stresses, aided by astral positions, either compounded or mitigated the severity of the disorder. Hence Ayurvedic principles forewarned the individual to take corrective measures long before a disastrous breakdown in health took place. It applied to all forms of life, with appropriate variations in the mode of observation and detection of states of disorder for there was only one guna law for all interactive processes.

### The Selfcharging Battery System

When a current is started in a circuit two actions can be identified. In a battery the electric charge resident in the cell structure of the plates immersed in an electrolyte, is assumed to be static as long as the terminals are not connected. The internal polarisation of the cells are kept in balance by an interactive oscillatory activity where the nett current is extremely small. The battery will run down eventually and is termed as leakage. On being connected across the two terminals the charge transmigrates along the connection as an interacting wave with unequal forward and backward displacements.

Analysing the very first interaction that initiates the transmigration of a charge at a rate C, due to the difference in the potential between the two terminals, the rate rises to C<sup>1+x</sup> through self similar interaction. The interval is its reciprocal where the difference between two interactions dissappear and the discrete or quantum field becomes a continuous field.

The rise of C<sup>1+x</sup> can be considered as an incremental ratio of C to C<sup>x</sup> . It is instantaneous (because of 1/ C<sup>1+x</sup>) and must be expressed as a log ratio as shown.

$$\boxed{\log\left(\frac{C}{C^x}\right) = 3.236068} \quad \boxed{\log\left(\frac{C^x}{C^{1-x}}\right) = 2}$$

Therefore an electric current will be due to the incremental value plus the normal resonant rate of C as :

$$\boxed{C \left( \log\left(\frac{C}{C^x}\right) - \log\left(\frac{C^x}{C^{1-x}}\right) + 1 \right)} = 8.79573 \cdot 10^{18}$$

$$440 \left[ C \left( \log\left(\frac{C}{C^x}\right) - \log\left(\frac{C^x}{C^{1-x}}\right) + 1 \right) \right]^{-1} \cdot \sqrt{2} = 1.607841 \cdot 10^{-19}$$



Secret Of Sankhya: Acme Of Scientific Unification.

The averaged reciprocal of the above figure is the measured

value of a current in coulombs. This is the interactive logic the battery too follows in transmigrating a current.

When the first parameter in F1 starts, the immediate reaction F2, (within a cycle), opposes F1 and its logarithmic difference gets added to the rate C as long as the potential difference across the conductor exists. The value F4 constitutes one ampere per second if one volt transmigrates across one ohm resistance.

The motive force for the current is in the Purusha or blackhole domain in space, identified earlier. Repeating the formula for convenience as F5 shows it is the winding numbers .

$$F5 \quad \left( \frac{Mps}{PM \cdot Px} \right) = 6.282665 \cdot 10^{17} \quad \blacksquare$$

The F5 value is the constant source of power in the substratum. If the rate of F3 synchronises into resonance with F5 the oscillatory state can be perpetually maintained. The rate of oscillation to maintain its internal charge is  $nn = 9.939535$  and to expand the radial  $k$  must be raised by  $nn$ , but  $k^{nn} = nn$  . This factor is unusual for it synchronises displacement and cyclic time to maintain resonance with the reciprocal value of charge.

$$F6 \quad \left( \frac{Mps \cdot nn}{PM \cdot Px} \right) = 6.244677 \cdot 10^{18} \quad \blacksquare$$

$$441 \quad \left[ \frac{\left[ C \left( \log \left( \frac{C}{C^x} \right) + 1 \right) - \log \left( \frac{C^x}{C^{1-x}} \right) \right]^{-1}}{\left( \frac{PM \cdot Px}{Mps \cdot nn} \right)} \right]^2 \cdot \frac{C}{C^x} \cdot x = 536.48355 \quad \blacksquare$$

Secret Of Sankhya: Acme Of Scientific Unification.

F7

The expansion rate of  $C^{1-x}$  times the cyclic displacement ratio  $x$  gives 536.48 cycles per second if  $C$  is the frequency at a metre wavelength in 1.010845 secs. If the battery current is switched on and off sharply, in the circuit configuration shown below, the batteries remain charged despite having a load that consumes considerable power. The battery acts as a large capacitor with a very small resistance, that generates a large pulsing current. The efficiency of transformation of the pulsing current is directly proportional to the sharpness of the switching off process.

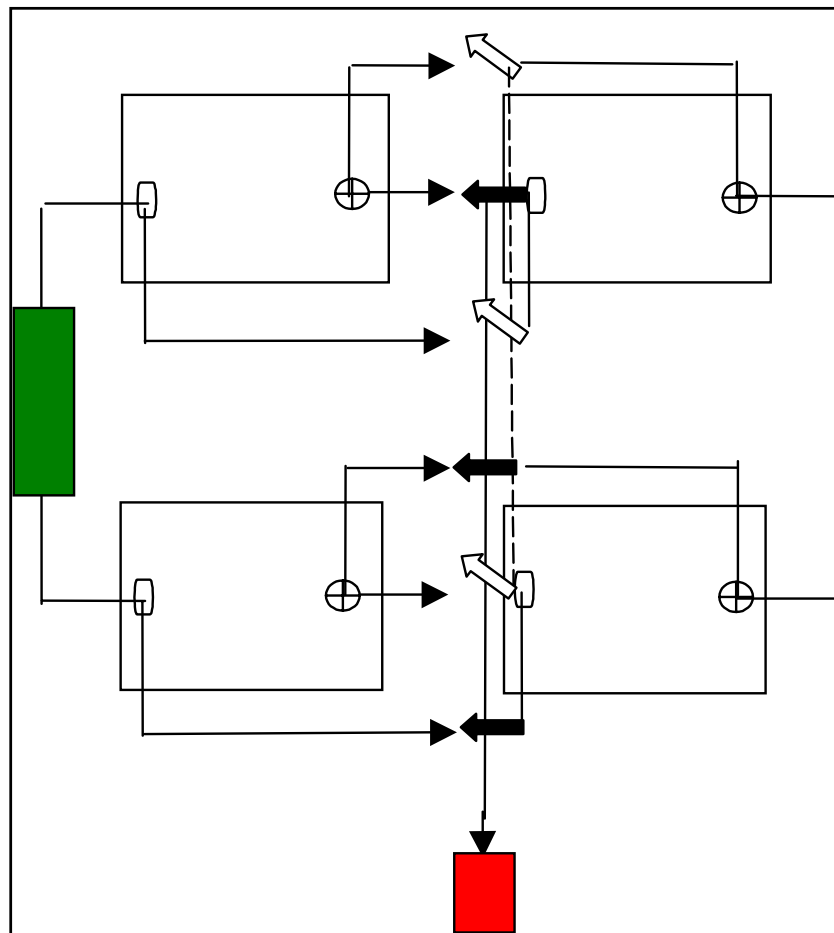

Secret Of Sankhya: Acme Of Scientific Unification.

Fig: The Selfcharging Battery System.

The green device represents the pulse transformer and the red unit the rotary high amperage sharp cut off switch operating at 536 cps. The 4 numbers 12 volt batteries are cyclically switched into a series connection of 24 volts while the remaining two remain in parallel to maintain 12 volts. In the next cycle the series parallel state is changed over . In effect the series 24 volt charges the 12 volt parallel units within 1/536 of a cycle and immediately change over to discharge across the other configuration. At resonance the batteries act as mere capacitors while the space field around the conductors act is inductive devices to provide the pulsing current. The transforming ratio of the secondary can be designed to match the load plus losses of the circuit thus imposing no power-load on the batteries. Experimental models have been test run successfully.

Interesting equations confirming the effect described above are given below.

$\frac{Mps}{tp} = 3.86824410^{35}$	$C^3 \cdot G = 3.86824410^{35}$
$\frac{C^2}{ec\sqrt{2}} = 3.88188210^{35}$	$\left( \frac{Mps}{PMPx\sqrt{rs}} \right)^2 = 3.86824410^{35}$

The C<sup>3</sup> G parameter is the maximum stress per cycle in space and as shown earlier it is resident in the Purusha state as a coherent ensemble of vibratory stress not in motion. Mps the equivalent Planckmass pulsed in plancktime tp produces the large stress value of ST. The formulation Mps/tp can be seen as the result of applying the impulse momentum theorem in Physics. The confirmation is shown as ec the value of charge of one  
443

Secret Of Sankhya: Acme Of Scientific Unification.

electron volt per second. The energy value of  $C^5 G$  represents the maximum rate of radiation of energy per second .

$$F9 \quad \frac{\left[ \left( \frac{c^x}{P_x} \right)^3 \cdot \frac{KV}{Ne \cdot c^4 \cdot 2 \cdot rs} \cdot \frac{Kx}{2} - \left( c^{1-x} \cdot \frac{x}{2} \cdot c^x \right)^2 \right]}{\frac{ec}{h} \cdot \frac{7}{(2 \cdot \pi)^2}} = 1.05523244 \quad \blacksquare$$

Overunity generation of power is only possible if the reaction time to initiate the next cycle is eliminated. Similarly perpetual oscillation can be possible if the time cycle to transfer the reactive output before the start of the next cycle is eliminated. The delay leads to the necessity of increasing the rate of transfer of the force needed to keep the system operating. A time lag keeps the initiating cycle following the sequence of action whereas it should be ahead. The conditions needed to sustain perpetual action or produce incremental power can be met only by using the systems internal energy to shortcircuit cyclic time delay. Feeding forward needs a system of control that can act faster than the state of the system that is in operation. Such a requirement needs additional power. Even if the power is available from the system itself it must be able transfer it ahead of the time to act. Hence a means to draw from a systems own internal energy is necessary for overunity or perputual motion.

A pendulum or swing is kept in perpetual motion by changing the state of the driving force or momentum in time. A child on a swing can keep the oscillations going continuously if it moves its body in time to initiate the next cycle at an accelerated level. A pendulum clock does the same thing by triggering at the right moment but with an additional energy input to overcme the loss due to

## Secret Of Sankhya: Acme Of Scientific Unification.

resistance. An internal combustion engine varies output with the same fuel input if the ignition system is advanced or retarded thereby proving the point of timing conditioning output for the same input.

The identification of a level of self or internal energy in a system is a prerequisite to sustaining overunity states. Internal energy states act as reservoir not only to provide the force but also initiate action ahead of the cyclic interval to sustain incremental states. Its depletion can be replenished at another part of the cycle provided incremental production is in operation. When a balloon is compressed from all sides simultaneously the rise in pressure is dissipated and the the entire quantum of rise in pressure can be utilised from the moment of reversing the process. If it is not simultaneous then the pressure does not rise to the maximum as it evens it out by displacement to other portions of the balloon that is not compressed. The rise is internal and can transfer to any region of the surface in the same time period..

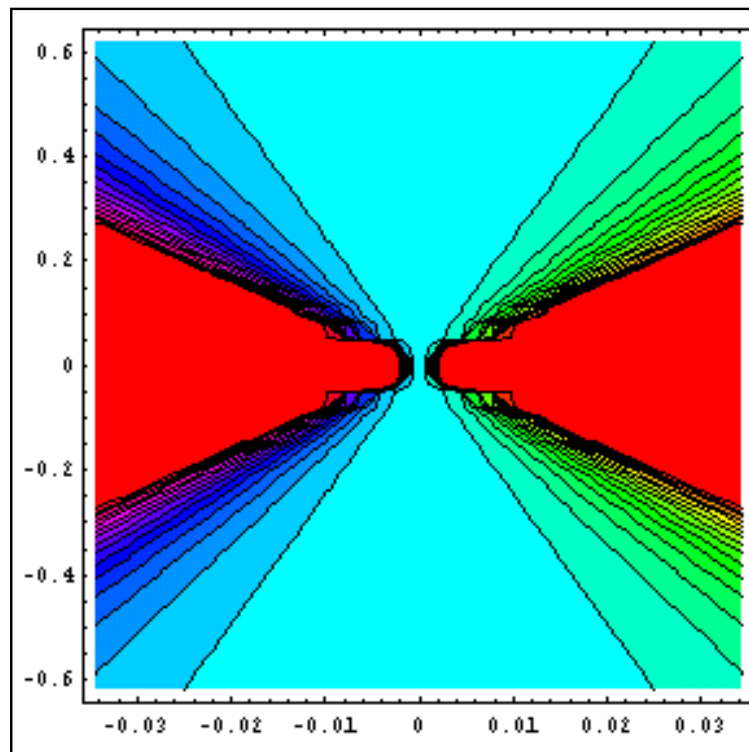

Fig: Sequential Interaction Time-Periods.

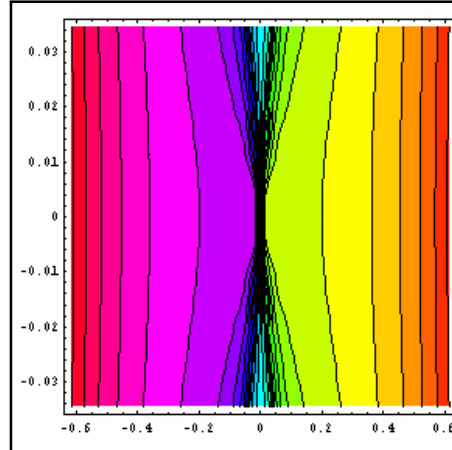

Fig.: Simultaneous Interactions.

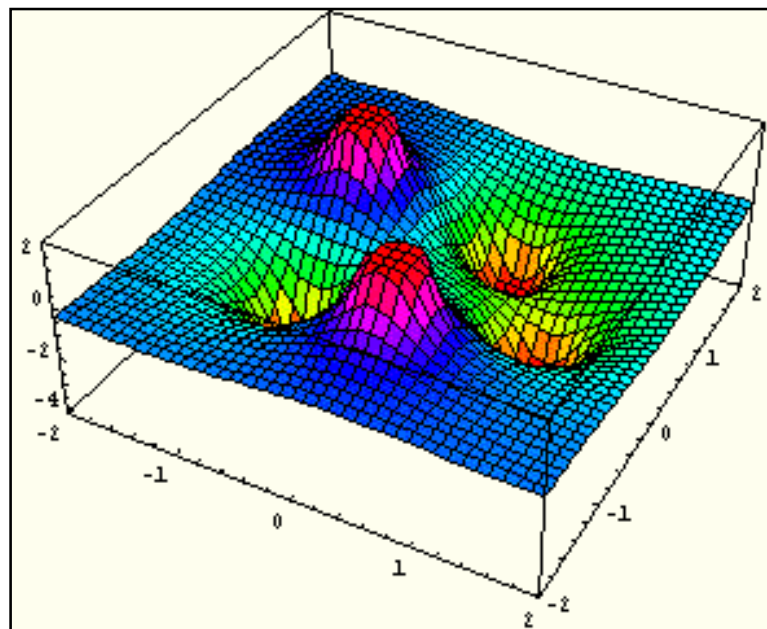
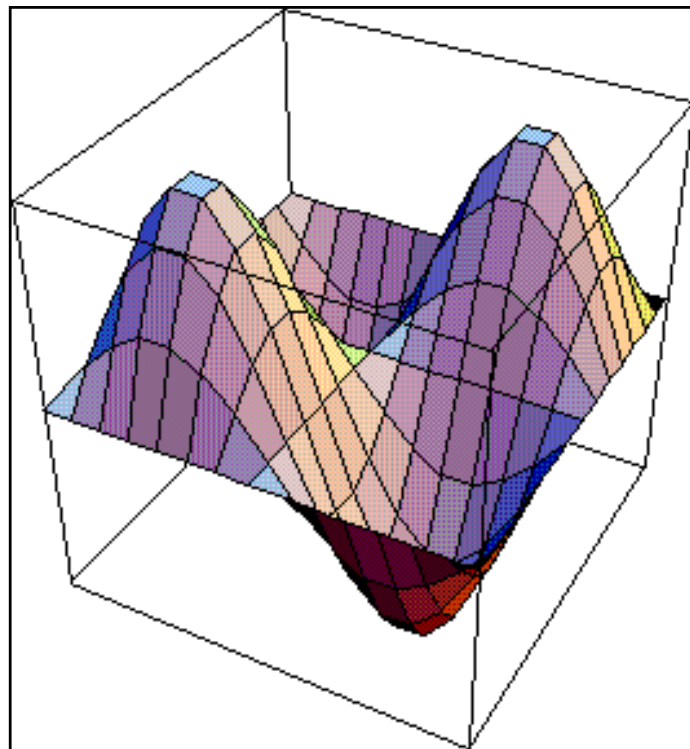

Fig: The Mahad Prakrithi/Vikrithi Exchange.

This conceptual diagrammatic 3D plot as a surface contour change gives an idea of the Sankhyan concept of simultaneous exchange between the Mahad Prakrithi or Planck mass density rise in planck time and the Mahad Vikrithi or Electron flux density rise in its own cyclic time. The actual change as a 3 dimensional stress transformation in the substratum of space will not be detectable unless it decays as an interaction. The Mahad Vikrithi Me or Electron is triggered into existence as an avalanche of a vorticular states by the Mahad Prakrithi Mps reaction in time cycle tp. The nature of power or energy developed in the shortest possible time is highly indicative of the impulsive or triggering interaction .  $Mps / tp = St$ , the maximum stress in the substratum, therefore it meant the maximum rate of energy radiation. It's power is proportional to  $C^3 G = 3.8 E+35$  cpc.



: The Stress Cancellation In Simultaneity.

The perpetual oscillations in space in a symmetric and coherent form cannot be detected as there is no change in the count rate, which is always C. But the stress transmigrate through self similar proportionality from one region to another alternately thus maintaining the state of unmanifest oscillation. The rise and fall or the height and depth are consistently matched and on the introduction of an upsetting or hindering 'triggering-interaction' the coherent potential breaks the synchronous and symmetric phase relationship to set in motion a displacement wave of varying stresses that transmigrate across the sea of components which form the substratum of space. The break in coherence initiates a 'spin' that has a quadrupole cyclic action. When in a quiescent and coherent state it is a simultaneous dipole oscillation that cannot be detected except for a 90 deg phase-shift. Electromagnetic phenomenon overrides this phase shift and cannot be detected.



## Secret Of Sankhya: Acme Of Scientific Unification.

### Appendix 1: Sankhya Translations Compared

Taking only the very first Suthra as the starting point for this comparative study the translations of the various authors show a certain hesitation in coming to a committed meaning of this verse. In a system of presentation that is terse and precise the student has no option but to assume and search for a profound and leading meaning in the very first Suthra, especially when a number of translators have been unable to see a justifiable reason for the differences in its interpretations. Also there is enough evidence from other Sanskrit Vedic treatises that the very first set of verses indicate the trend of contents of the ensuing subject matter. Since Sankhya pre-dates all other works (acknowledged by the majority of translators) it should be decoded rather than translated by referring to other works. There is a definite clue in Suthra 69 that it is a secret doctrine meaning that it should not be dealt with in a standard way. Moreover there is direct evidence from the Sankhya Karika itself that the meditative or holistic thinking process should be followed in interpreting the Suthras, for any language is built up by a structured logic based on human experience and is conditioned by the environment and period in which it is developed. Since it is difficult to pin down with absolute certainty the meaning of key words that may have changed with the passage of time, holistic imaging leading to three dimensional visualisation of complex phenomenon is the next closest means to interpreting reality, correctly. As a case to point, almost all the major epics like the Mahabharata and Ramanya are presentations of complex and profound scientific concepts through dramatic enactment. It is a substitute for a modern video presentation. Maharishi Kapila has specially dealt with the process of verifying the correctness of information through a number of Suthras that teaches the student to

449

## Secret Of Sankhya: Acme Of Scientific Unification.

use holistic imagery through meditation. The proof of the previous statement lies in the current explosion in graphic techniques as a means of presenting complex information visually to enhance understanding. It confirms the well known cliché that a picture is worth a thousand words and meditation amplifies it a millionfold by making it a dynamic real time process. It is also the reason that all important religious and philosophical principles are set out in the form of parables, stories or mythical constructs.

Many translators have given this special work a derogatory meaning by describing it as being pedantic, dogmatic, repetitive etc. The main reason, giving rise to such an impression, is that the intrinsic meaning of specific words remain precisely the same throughout because they are HOLISTIC picture-definitions of compact, condensed ideas and principles. A reader who lacks a knowledge of meditative techniques, gets the feeling of it being pedantic mainly because of his inability to understand the true import of the verse. In the write-up below, the very first verse is presented as a decoded sentence so that the divergence in the meanings given by several translators can be readily seen.

### **Suthra 1.**

The holistic meaning of the words are given here. See the Sanskrit lexicon in appendix L specially developed to make this treatise understandable. The implied meanings of each word has been verified by using statistical techniques.

Secret Of Sankhya: Acme Of Scientific Unification.

***du:khatrayaabhighaataajijnaasaa***

Stress- triple- interaction- investigations

***tadabhighaatakey hetau,***

Such -interactive-modes exist

***drishtey sa'apaartha***

detection of such would have been meaningless

***chennAikaanthaathyanthatho'abhaavaath***

were it not for the synchronised-perpetual-dynamic  
unmanifest state.

Meaning:

**Investigating the triad of interactive stresses confirms that such interactive modes of stresses exist but it would not have been detectable, had it not been for the existence of the synchronised - perpetual - dynamic - unmanifest state of existence (of the substratum).**

**Gaudapada's version:**

Transliterated into English by H. T. Colebrooke:

The first Suthra is interpreted by Gaudapada as follows:

**"This inquiry is into the means of precluding the three sorts of pain; for pain is embarrassment: nor is the inquiry superfluous because obvious means of alleviation exist, for absolute and final relief is not thereby accomplished."**

From the above exposition, the key elements of Gaudapada's subsequent commentary and elucidation are "embarrassment due to the three sorts of pain" ; classification of the three types of pain as "adhyatmika or natural, adhibhautika or extrinsic and adhidaivika or superhuman" , "the means of precluding them", " the  
451

## Secret Of Sankhya: Acme Of Scientific Unification.

superfluous nature of this exercise” and its uselessness as it is “not absolute, final , certain and permanent”

Summarising his subsequent commentary on this Suthra consequent to the interpretation given above: It classifies the three types of pain and the medical modes of alleviating them but it is concluded that as these means are not final, other permanent means are to be inquired into, implying the existence of an esoteric method to cure such pains and sufferings. From the above it became amply clear that the first Suthra dealt with pain and suffering.

Observation:

Gaudapada's version predates the other translations and has unfortunately influenced later authors to take up his slant. While one can forgive his interpretation as the state of science was still in its nascent stage then, subsequent authors could well have had the courage to decode the real meaning and the perspicacity to factually relate it to the trends in scientific knowledge prevailing in their time. His conclusion is that it relates to human physical suffering and fails to see any connection to nature and phenomenon. It is surprising that this conclusion has been presented, for in his translation of the second Suthra, he refers to discriminative knowledge of manifest and unmanifest principles and the soul. His commentary on the third suthra is even more explicit about nature and its mathematical structure but no effort had been made to translate the first suthra from this level nor had the meaning of 'abhigatha' been examined critically in conjunction with 'chenna'. The 68th Suthra (effectively the last) gives a clear indication of the nature of the statements by repeating the key words, but this sense has not been assimilated contextually into the first Suthra. The clear opening trend of sankhya as an investigation into the

452

## Secret Of Sankhya: Acme Of Scientific Unification.

nature of the substratum of space has been completely missed and the entire set of 68 verses turned into disparately connected explanation trying to justify the prevailing philosophical thoughts of his period. The importance of "Aikaantha-aathyantha-atho-abhavath" as a key phrase has not been recognised by him nor has he seen the profound meaning it gives on extending it to the 68<sup>th</sup>. Suthra . The term du:kha has been misinterpreted despite its descriptive term “traya” that is evidently connected with the triguna principles. Such a deviation in the very first Suthra underscores the error in not perceiving Sankhya as a pre-glacial creation as hypothesised by Lokmanya Tilak (see appendix G)

### **2. H. H. Wilson's comments:**

He states that the first verse proposes the subject of the work and also of the system it belonged to namely the Hindus. They sought exemption from repeated births as life was a state of pain and suffering, bondage and evil, and escape from which was devoutly to be wished. He also refers to the different interpretation given by Lassen to the two important terms “abhigatha” and “chenna” and after a lengthy analysis, takes exception to it on the grounds of its implied meaning deviating grossly from that of Gaudapada and Colebrooke.

Observation:

He expresses views almost identical to Gaudapada and the supportive Colebrooke commentary but sees vaguely the possibilities of an esoteric scientific logic being expressed to explain the soul etc. The second and third Suthras are dealt with on Gaudapada's lead but he seems oblivious to the inconsistency in the run of logic and subject matter. The importance of the "Aikaantha-aathyantha-atho-abhavath" as a key phrase is not recognised by him.

### **3. Lassen's version:**

In his commentary in Latin, he has been the only person among all other translators, to raise the doubt that the real meaning of the term "chenna" leads to the conclusion that the final word could be "abhavat" but seems unable to alter the rest of the structure to make this change meaningful. He further deduces the meaning of 'abhigatha' as 'impetus' but uses 'removal' for the same word later, thereby acknowledging the meaning given by Gaudapada. The commentary is concluded on a controversial note with no definite outline of the true meaning. He seems to see the term "chenna" being an incongruous addition and rightly suspects the first Suthra as having a significant scientific meaning. But these views are not given weightage by any of his critics. Despite his doubts based on the possibility of an elliptical meaning, the importance of the "Aikaantha-aathyantha-atho-abhavath" as a key phrase has not been recognised by him either .

### **4. Gerald Larson's version:**

Translation:

" Because of the torment of the threefold suffering, (there arises) the desire to know the means of counteracting it. If (it is said that) this (desire --i.e. Inquiry) is useless because perceptible (means of removal are available) , ( we say) no, since perceptible means are not final and abiding."

Commentary:

While he has dealt with it at length in his commentary, the last sentence in his preamble in chapter 3 gives the true tone of his subsequent explanations. He says " Hopefully our interpretation will reveal that Sankhya is dealing in a significant manner with some of the most difficult problems of religion and thought." He further adds in appendix B note 2. " Generally, the present writer has

454

## Secret Of Sankhya: Acme Of Scientific Unification.

followed the commentaries of Guadapada, Vacaspatimisra and Paramartha's Chinese version with respect to problems of interpretation ."

In chapter 1, he groups the first three Suthras and gives a combined interpretation pointwise as follows:

1. Human existence means suffering;
2. Sankhya system offers a way of salvation from suffering;
3. The way of salvation is by means of discriminative knowing;
4. The concept of saving knowledge is through discrimination of the differences between avyakta-vyakta ( prakriti) and jna (Purusha).

Under the heading of "Philosophical " he says "little light is shed on the content of classical Sankhya as it is found in the Karika itself. Part of the problem, of course, is that the Karika is a difficult text which presents the system in a dogmatic, condensed fashion. Thus it is natural to use any other available texts in order to get at some of the underlying suppositions and arguments not explicitly set forth in the Karika itself. Yet the fact remains that the Karika is the oldest systematic text available and it represents the content of classical Sankhya. Important to remember is that what the Karika fails to include is as interesting as what it does include. It is the contention of the present writer that the Karika can and should be given a unified, consistent interpretation in and of itself without recourse to later texts. It is also the contention of the present writer that the system in the Karika is decidedly different from later statements about the system , and furthermore, is quite different from the most commonly accepted summaries and outlines of the system presently available in the secondary literature."

**Observation :**

From the foregoing it is evident that Larsen realises the originality and uniqueness of the Karika but fails to follow his own findings but takes the lead given by others like Gaudapada. He does not give weightage to the first Suthra and particularly the last line. Though in the 68th Suthra the same words recur as an elliptical proof following the lead given by the word "chenna", this connection is not pursued by him either. Though his translations of Suthras 2 and 3 are more indicative of the scientific nature of the treatise and his grouping in items 3 and 4 of the first 3 Suthras clearly suggest that it is a science, the importance of the "Aikaantha-aathyantha-atho-abhavath" as a key phrase is not recognised by him. If any one could have seen its true import Larsen was the most likely person because of the care he has shown to give contextual weightage to each word of the Suthra but for some inexplicable reason had failed to apply his intuitive understanding in his commentaries. In fact his final conclusion is quite incongruous to his philosophical description of Sankhya when he translates Suthra 68 as "At death , however the man who possesses salvation knowledge attains 'certain' and 'final' 'isolation' ".

There is no comment about the term 'du:kha' or "Aikaantha-aathyantha-atho-abhavath" even though he expresses deep dissatisfaction at his results. In expressing his dissatisfaction, he has described the Adi Sankaracharya's criticism of Sankhya as being based on interpretation unfounded by even a minimal stretch of logic. However, he personally seems to have succumbed to the same attitude he accuses the Sankaracharya of holding the Vedas as being unquestionable because of its allegedly divine origins. From his lengthy analysis and conclusions one is able to glean his dissatisfaction with the overall meanings given both by him and his colleagues to the

456



## Secret Of Sankhya: Acme Of Scientific Unification.

Suthras but has been unable to breakout onto a different lead. Of all the translators he seems to have been the only one to feel the need to decode the sankhya verses.

### **5. Richard Garbe's version:**

While admitting it was a philosophical work by one person, he emphasises its apparent atheistic leanings, based on reasoning to solve the universal problems. In this context he suggests its suitability for modern study. His commentaries are based on those of Aniruddha and Vijnanabhikshu on classical lines giving in to the same pitfalls. However he intuitively comes to the conclusion that it is the earliest treatise and as proof he points out the lack of a brahmanical tradition that is established strongly in later works. Despite his intellectual foresight he does not give enough weightage to the critical term in the first Suthra, "Aikaantha-aathyantha-atho-abhavath" nor the word "du:kha".

### **6. Joseph Dahmann's version:**

He describes Sankhya as the first systematic formulation of ancient speculations, that included dimensions of cosmology and psychology of creation /dissolution. He interprets it as a doctrine of salvation based on the concept of an absolute Spirit with techniques for self control and behaviour. He found it methodical and consistent. But his views of the Suthras themselves are not clearly enumerated to show his depth of understanding. No weightage has been given by him to the term "Aikaantha-aathyantha-atho-abhavath" or the word du:kha.

### **7. Paul Oltramare's version:**

His views are similar to Garbe but sees Sankhya as a unique system expressing the dualism of matter and spirit and a derivative from the brahminical tradition with the concept of Yoga predating it. No weightage is given to the term "Aikaantha-aathyantha-atho-abhavath"

**8. Hermann Oldenberg's version:**

He refers to the existence of a pre-classical Sankhya that predates the oldest upanishads. He also mentions the complementary use of logic in Sankhya like unity and multiplicity, subject and object, self and nonself etc. The sense of Sankhya logic is brought out by him uniquely, but no weightage is given to the term "Aikaantha-aathyantha-atho-abhavath" that indeed contain the same sense of complementarity.

**9. Arthur Barriedale Keith's version:**

He sees Sankhya as a bundle of contradictions contemporaneous to the Vedas and Upanishads. His involvement has been with semantics rather than the holistic meaning.

**10. Franklin Edgerton's version:**

He views the treatise as just a method of attaining salvation without any theory behind it. He comes to this conclusion because there is no mention of a Sankhya system in what he considers as earlier works.

**11. Surendranath Gupta's version:**

He has delved into Sankhya details in the most systematic way to realise its true scientific logic but sees the whole system as post Vedic. Despite his enthusiasm for looking at the evolutionary logic of Sankhya in the correct way he misses the point about suffering really meaning stress in the universal sense and fails to see the important connection to the substratum or "Aikaantha-aathyantha-atho-abhavath" state.

**12. E.H.Johnston's version:**

His writings concern the history and the terminology and seems to identify Sankhya as a complex mixture of contemporary thought.

**13. Eric Frauwallner's version:**

Offers the view that Sankhya is the earliest speculation on cosmology and philosophy. The special attention to some

## Secret Of Sankhya: Acme Of Scientific Unification.

words and its connected concepts are realistic and his attribution of the development of Sankhya to Pancasika is illuminating . However he offers no insight into the term "Aikaantha-aathyantha-atho-abhavath" nor does he see the term pain as being out of place here.

### 14. Others

There are a number of other translators like J.A.B. van Buitenen, J.W. Hauer, Mircea Eliade, Debiprasad Chattopadhyaya, K.C. Bhattacharya, who have displayed erudition in analysing the Sankhya terminology historically and contextually against several later Vedic treatises and left mixed conclusions in the mind of the reader. Others like Dr.Radhakrishnan, C.Sharma give only a comparative critique against a background of Advaitic Vedanta. Most Indian translators have treated Sankhya in a reverential way which obviously prevented the authors from interpreting it objectively. Most of the other Indian translators can be placed into two camps, "for" and "against". Among the "for" the direction has been to extract startling conclusions from disconnected sections without any effort at unification to highlight the coherent and continuous adherence to a single core principle in Sankhya and most of their works tend to leave the reader more confused than enlightened.

### 15. Conclusion

One important point emerges from an overall analysis and generalised understanding of the commentaries given by the various translators. All of them have noted the existence of a deeper philosophical principle in the Sankhya presentation, which naturally implies that the meaning of the first Suthra should also be re-interpreted to seek such a connection, as the rendered version of the first Suthra certainly does not emphasise its profoundness. Looking at the meaning of the first Suthra in a holistically connected way , as shown in the fourth paragraph of this appendix:

**Du:khatrayaabhighataj -jijnasa**  
**Tadabhighatake- hetau**  
**Drishte sa'apartha chenna**  
**Aikaanthaathyanthaatho'bhavath**

**Investigating the triad of interactive stresses shows that such interactive modes of stresses exist but it would not have been detectable, had it not been for the existence of the synchronised - perpetual - dynamic - unmanifest state of existence (of the substratum).**

The proof is as follows:

The term 'du:kha' has a very specific meaning of “stress related to the substratum of space” for the following three important reasons:

1. The term traya defines a numerical condition of the subsequent term as being threefold. Abhighatha has the meaning of "striking or extirpating" The sense of this word has a certain degree of intensesness or violence implied. The process of an interaction by impact or collision in three different ways namely by compressive, expansive and shuttling action of the guna characteristics would seem to be the most appropriate one since the concept of Gunas are extensively dealt with, from Suthras 11 to 22. Further Suthra 30 refers to simultaneous and sequential modes in a cycle which mathematically translates to a third order damping constraint due to obstruction. Words usually associated with pain, like removal, elimination, curing could have been covered by other precise Sanskrit terms; for instance 'apasaarann.' the term 'abhighatha' has been specifically chosen to imply a colliding, impacting, interactive type of stress acting in

460

## Secret Of Sankhya: Acme Of Scientific Unification.

three ways and not pain. The precise definition of the Guna characteristics in later Suthras confirm the above meaning and gives the entire work a cohesiveness that enables the student to realise its profoundness. This interpretation is well supported by the subsequent Suthras, as shown below.

2. The second occurrence of the term du:kha (the first occurrence is in the first suthra) in suthra 55 has been used twice in the same suthra, emphasising its role as a technical term within the contextual meaning of all the Suthras from 52 to 60. If it is objectively and critically viewed, in the background of these Suthras, the applicable meaning of the word du:kha cannot be pain. Though the term du:kha does not recur in any of those other Suthras, the trend of ideas preceding and following 55, pertain to the descriptive definitions of various factors surrounding the nuclear core, Purusha.

Suthra 52 deals with dual phases of phenomenon;

Suthra 53 deals with the classification of phenomenon;

Suthra 54 deals with the Guna characteristics of the manifest field;

Suthra 55 deals with the gradation of stresses (DU:KHA) upto the nuclear core as a self-similar process.

Suthra 56 deals with the evolution of the isolation of the nucleus from the interactive field.

Suthra 57 deals with the collapse of the nuclear entity as the primary force

Suthra 58 deals with the release of the potential that causes the nuclear collapse.

Suthra 59 deals with the process of balance as the equaliser of the forces

Suthra 60 deals with the static and dynamic qualities that bring about the balance.

## Secret Of Sankhya: Acme Of Scientific Unification.

As can be seen plainly from the foregoing, the term DU:KHA is not used in the context of human sensory feelings like pain, suffering etc. but it does not exclude the inclusion of human suffering as a form of stress due to a departure from normal, natural and correct action or behaviour.

3. The current dictionary meaning of du:kha is pain or difficulty. However the term "du:" is to burn or to afflict or cause difficulty and "kha" has a number of meanings which include the sky, heaven and brahma. Therefore the contextual meaning of the term du:kha is stress or difficulty related to the sky, heaven or brahma which is equal to the fundamental field of the substratum in the fluid state. In vedic creations Shiva is a pedagogical acronym for the (log) numerical value 8 (shi) descending to 4 (va) that epitomises the thaamasic state of total inertial power of the andhatamisrah (blackhole) state of 18 orders of magnitude, symbolised by the shivalinga with 18 shivagannas. Brahma, is an acronym for (log) numerical 3 (ba) and 5 (ma) shuttling around 4, epitomises the rajasic fluid state of resonance symbolised by the  $10^3 = 1000$  petalled lotus floating in placid waters. Vishnu is an acronym for (log) numerical 4 (va) expanding to 8 (sha) epitomises the radiative satvic state symbolised by the axiomatic vibratory rate of 259 cycles from a conch shell rising to the axiomatic 8<sup>th</sup> order of magnitude from the luminous chakra. Therefore the term du:kha could be correctly applied to the stress or force generated in fundamental space or the dynamic substratum in which all phenomenon originate and even more appropriate is the concept of the three gunas as interactive stresses generated within it to maintain a balance.

Further, if one accepts the term du:kha equals pain due to human suffering, then a very glaring break in the logical continuity, of an extremely cogent set of Suthras, is

462

## Secret Of Sankhya: Acme Of Scientific Unification.

exposed; which requires a coherent and rigorous explanation as to why this term has not been amplified and explained in detail in any of the later Suthras? When Suthras 46 to 53 lists out in detail variations in different types of interactive actions and reactions that are not referred to anywhere else, why would an intellectual giant like maharishi kapila leave out an important classification of 3 modes of pain allegedly referred to in the very first suthra? The three descriptions of pain are given only in the commentary by gaudapada but there is no other connection or usage of these terms in the entire set of 70 Suthras, implied or otherwise.

The connection with human suffering and pain has been brought in as a pure conjecture by the authors. As shown earlier, the term du:kha occurs again only in suthra 55 but with reference to context of the sequence of adjoining Suthras, it has no connection (even remotely) with human pain. Further the term traya has a direct and important connection to the guna definitions mentioned exhaustively, which then rules out even a semblance of relationship to a stray term like pain or suffering that have been neither emphasised nor touched upon in any of the other Suthras.

From this critical analysis one can conclude with logical certainty that the term du:kha refers to the three modes of stress or states of non-synchronisation in the substratum for only then the rest of the Suthras yield a wealth of information that goes even beyond the boundaries of our current scientific knowledge. The most striking and conclusive proof that it refers to the substratum is the fact that Suthras 47 to 53 identifies precisely the numerical sequence of the atomic periodic table evolved in physics and chemistry and goes further to identify the hidden coherent quark sequential blackhole structure that physics is currently searching for in vain. The outstanding algorithm given in suthra 3 could never have been translated if human suffering was the correct meaning.

## Secret Of Sankhya: Acme Of Scientific Unification.

The mathematical super symmetry existing in the substratum could never have been exposed, by an accidental mistranslation of the word du:kha. Considering the published findings in current science, the numerical constants of super symmetry are not yet known yet sankhya principles accurately derive these numerical values. Hence du:kha, as used in sankhya, **is certainly not pain.**

It will be most inappropriate to leave out the analysis of the Adi Sankaracharya's (around AD 750) on the Sankhyakarika. His entire criticism of Sankhya had been made with a single viewpoint of not allowing the Vedic foundation to be shaken by even the most profound logic if it did not complement it. While he used every identifiable uncertainty in the definition of logical concepts to question Sankhya principles in order to safeguard Vedic injunctions, it is apparent that it had been done on the apparent understanding that the Sankhyakarika was post Vedic and was based on atheistic principles that tried to remove the divine foundation of Vedic aphorisms. What Sankhya treatise reiterated was that axiomatic truths or 'Aptavachana' ( Suthras 4 and 5 ) are permanent; but not every Sanskrit word in the Vedas.

Hence terms like Aptavachana, Aptasrutir or the axiomatic status of permanent validity, endowed the mantle of divinity without question and the spirit of the Sankaracharya's understanding was entirely preserved. It is quite indicative of the temper of that period where a matter-oriented, mechanical description of the Universe that apparently implied the exclusion of the "spiritual" aspect, was not acceptable and summarily dismissed. The astounding part of Sankhya is that it proves unequivocally that the so called 'mechanical or material ' matter is in fact a purely 'spiritual or vibratory or non specific' state in a holographic universe. Hence an axiomatic base provides it with the divine classification that cannot be disproved

464



## Secret Of Sankhya: Acme Of Scientific Unification.

even by the most complex mathematical logic and more so by any pedagogic logic. Therefore the apparent contradictions between intellectuals was only due to superficial differences, for on greater analysis and deeper thinking all the conundrums resolved themselves as merely the complementary aspects of human intellectualism.

The following explanation is in defense of the apparent lack of a successful outcome of past researcher on Sankhyan concepts. It is very evident from the mode of presentation of the Sankhya Suthras, that Maharishi Kapila has been impeccable in his derivational logic and by maintaining the strictest accuracy in defining the components of its axiomatic logic, he motivated the student to establish the connections by a process of rigorous analysis of the Suthras through a meditative technique outlined in Suthras 4 to 6. Hence he did not define the substratum of space by any single common noun but maintained his objectivity by axiomatically defining it by the four states of interactions as 'Aikaantha-aathyantha- atho- abhavath ', only once in the first suthra but indirectly referred to it in every suthra by the word ' chenna = were it not for' . Thereby , not only did he fulfil the needed logical rigor but also displayed the ultimate in reverence, respect and obeisance to the fundamental Source and Sustainer of the entire Cosmic phenomenon. Even in the Vedas it is 'That'. Hence the epithet that Sankhya is an atheistic production is not correct. On the contrary it unifies theology with science. Failure to apply the meditative technique to decode the mathematical axioms seems to have been the cause of not understanding the Sankhya Karika by the earlier authors.

NOTE: It is evident from commentaries and reviews of the original Vedic and Puranic verses, the various authors (of that period) had no inkling of the real time gap  
465

## Secret Of Sankhya: Acme Of Scientific Unification.

that existed between themselves and the subject matter under their review. Only future progress in science will do full justice to the meaning of the Suthras. The current level of proficiency in holistic mathematical logic needs to be raised to its full potential and only such a process will aid total comprehension when dealing with self similar laws of nature. The saying that one picture is worth a thousand words is apt when one realises that one needs numerous iterative mathematical formulas to draw a picture mechanically on a computer. The human mind can grasp the essential meaning of the picture in an instant whereas the mathematical formulas would only indicate a trend even to the most astute mathematician. While mathematics is necessary as an important tool to enhance understanding it has to be augmented with human holistic mental intelligence to grasp nature's axiomatic principles. Man has to realise that both language and mathematics are codes that are only useful for communicating ideas or principles to others, but total understanding and comprehension of phenomenon at the personal level are beyond the limits of such codes and in fact there is no need for them in a holistic meditative thinking process. In that sense true literacy leading to abundant wisdom is not dependant only on learning these codes but on using the skills of the human cerebral system fully and completely. Sankhya Karika also called Sankhya Yoga shows the perfect meditative Siddhi technique of achieving perfection in the thinking process in Suthras 4,5 and 6.

## Secret Of Sankhya: Acme Of Scientific Unification.

### Appendix 2: Origin Of The Vedas..

(Article in World Affairs, vol.6, No.3 Jul/Sep 2003.)

The Vedas have roused man's curiosity around the globe at one stage or another. Just to know that so many intellectuals dedicated themselves to unravelling its meaning, is a tribute in itself, even though they failed to agree as to what the ancient creations really meant. Some extolled its virtues and praised it to the skies. While others weary from wresting a meaning, condemned it to the dungeons of despair. Are the Vedas an esoteric creation and if so who composed it in ancient times? Thereby hangs a historic tale of an intellectual colossus, who

467

## Secret Of Sankhya: Acme Of Scientific Unification.

mathematically solved the riddle of manifestation aeons ago.

One is immediately prompted to raise the question 'why was it's real meaning not exposed in all this time'? Some modern intellectuals attempting the translations misjudged its scientific content for one thing. An erroneous 6000-year guesstimate of its origin prevented researchers from suspecting a possible difference in meaning of words from an older form of Sanskrit. For instance in current Sanskrit the term *Du:kha* means 'pain' but in the older version it is 'stress' as a technical term. A not so widely known fact was that Vedic authors of oral creations depended on the natural process of 'experiencing' real information as an ideal way to understanding phenomenon. Today animated graphic techniques make it easy to communicate the most complex ideas. In Vedic times too, the same principle was used to produce a dynamic imagery through a precisely formulated oral system. The verses contained six types of controls as rhyme rhythm, tone, inflection, emphasis and onomatopoeic meaning. Applying these factors to each set of verse 'simultaneously' through the learnt 'meditative Siddhi technique' created a real experience in the mind. The Dharma Mega Samadhi state helped to understand the meaning the author tried to convey. This process established an unequivocal understanding of the author's purpose in creating the verses. The Pratisakhya, also in a similar metric form as an adjunct to each Veda, aided it. The fact that the original authors saw the need for a supplement to aid comprehension provided an important clue to Vedic profoundness.

The foregoing is an important reason why the 'non-meditative' translations of the postglacial re-written manuscripts invariably yielded utter gibberish. Most translations failed because the researchers made the serious error of splitting up sets that destroyed a verse's contextual meaning in a Siddhi process. Few had that patience, except

468

## Secret Of Sankhya: Acme Of Scientific Unification.

perhaps Swami Vivekananda, Sri Aurobindo, Lokmanya Tilak and Jagadguru Bharathi Krishna Thirtha among others. They took the difficult route of going through the original versions. The Lokmanya and the Jagadguru investigated, hypothesised and had the courage to write about it. Recent research indicated that Vedas contained a very advanced axiomatic theory of a Universe. It functioned on a holographic basis or through the concept of Maya which was misconstrued as an illusion. Such an advanced concept unequivocally unified the controversial 'material / spiritual' divide through axiomatic mathematics. Even today, Physics and Cosmology are strangers to the holographic concept as applied to the Universe. Probably scientific translators too would have had to wait for the research environment to catch up with such ideas.

The present writer crossed the barrier of disbelief due to a fortunate set of events. Decoding the very first Sloka of the Rigveda, correctly, yielded a novel 'energy extraction principle'. It led to inventing an unusual electric motor that violated known electromagnetic principles (see details presented below). Similarly, the first Sloka of the Atharvaveda yielded, by decoding correctly, a profound energy principal. It led to the fundamentals of quantum physics and the very foundation for a holographic phenomenon. It gave a decisive clue to the source of coherent energy in space. Tests carried out with an invented device (currently under improvement) confirmed that concept. Was it a coincidence that the very first verse in the Rigveda and the Atharvaveda defined the very first fundamental principle in electromagnetic and quantum theory? These experiences led to decoding ancient man's greatest and ultimate scientific achievement in the Vedas. That process found the ancient man turned out to be the teacher for mankind!

Science of the rational.

## Secret Of Sankhya: Acme Of Scientific Unification.

The reality of the Universe is an axiomatic fact. Yet, a human-centric intellectual would not let it pass without a challenge. His argument would probably emphasise the duality seen in every aspect of human existence. Hence, he would postulate the need for an observer to confirm the existence of the observed. The implication being that in the absence of an observer the Universe just 'disappears'. This conceptual hyperbole exists at the very altars of our scientific temple. Both the 'concepts of particle-wave duality' and 'principle of uncertainty' were self-explanatory anomalistic principles that existed in Theoretical Physics (Physics). Then there were the enigmatic quantum fluctuations in a supposedly empty and vacuous space. The theory of Special Relativity (SR) exposed space-time contractions involving shrinking rods & slowing clocks which seemed to defy common sense perceptions. The unexpected failure of the Michelson Morley experiments to detect the medium for propagation of light in space spurred many of these principles into existence. The reason behind the plethora of unusual scientific principles is just one simple fact.

A measurement is an interactive process that takes time. Until the interaction is complete or the measuring cup is full, the observer cannot complete the act of measurement. This fact applies to observers of both the human and instrumented kind. The latter is merely a sophisticated extension of our sensory processes. Even the very act of observing the Universe is a process of measurement. The perplexing point here is when does the observer know the interaction called measurement is actually completed? So the observer invents a clock that shows an interval he arbitrarily calls a second. Then he moronically compares all measurements in terms of this holy second. The result was as expected, uncertainty. Imagine a blind man filling a measuring cup for a second when it actually needed just one tenth of a second. The scientific researcher had been

470

## Secret Of Sankhya: Acme Of Scientific Unification.

doing just what the blind man did, overlooking the nine cups that overflowed. The natural consequence of such a process was somewhere down the line the measurements refused to tally. And that despite established standards of accuracy, in a catchword called dimensionality that did not match up to the real Universe. Was there a way to tally this huge loss? The perfect answer comes from unbelievable quarters, for it transcends the history of modern man.

The desire for fame, wealth and the consequent pressure, from the fiercely competitive world of national finance, compounded by the invisible world of scientific peerdom, drove researchers to establish credible avenues of escape from unresolvable errors. The process of redemption was to dilute every serious and irreconcilable error through a profound principle. It is unbelievable but true that every profound principle in Physics and Cosmology, gloss over areas ridden with hidden problems that defies human understanding. After the Newtonian magnum opus on Gravitation in the 17<sup>th</sup> century, the twin theory of General and Special Relativity (GR and SR) offered the key to resolving the manifestation process.

Unfortunately, it opened the doors to a nest of Pandora's box-of-anomalies. Its prime anomaly, the perpetual 'equality of gravitational and inertial mass', was quickly laid to rest by propounding the Principle of Equivalence. The next major anomaly, was the necessity to find one of the nine lost cups, called the Cosmological constant. It was needed to balance the complex GR equations. Before long, another unresolvable anomaly turned up accidentally, which bailed out the GR theorems. Hubble, an astronomer, discovered an anomalous and enigmatic behaviour in the expected result of spectral measurements. It was in regions where, man the observer, could never physically verify. The rate of measurements, through his extended eye the telescope, seemed to get slower and slower as man peered future and further into the Cosmos.

## Secret Of Sankhya: Acme Of Scientific Unification.

Hubble 'theorised' that could happen only if the Universe was expanding, like a rubber balloon. Einstein immediately saw the avenue of escape to hide the missing cup in his GR conundrum. From it evolved the grossest theory of the Big Bang expanding Universe. Kind nature did not comply, for instead of hiding at least that one-cup to mollify the GR inadequacy, it sprang a surprise of an equally gross order. Other researchers from the cosmic bench went on a search, for there was a tremendous shortage of the basic stuff, the so-called dark matter in empty space. And GR needed it immediately to ward off the collapse of a theory that predicted the ultimate cosmic collapse in the Big Bang. Something very mysterious was happening. For the equations, that had not even spotted the missing nine cups, cried out for just one more cup. While Hubble ostensibly provided it just in time to support the expansion, the cosmologists were calculating the number (running into billions) of cups, needed to start the contraction. A fundamental question arose in the minds of the fraternity. Was the Universe really expanding and then whereto? If not, into what will it contract? And as the questions increased, science kept discovering more phenomena, which promised to decrease them, through a paradigm called unification.

Moving to the seat of action, space, where the treasure-chest containing the perfect answer hid, researchers found a revolution taking place, in thinking 'small'. In the early 1900's a series of anomalies cropped up that defied common-sense solutions. Stating it in lay language experiments on transmission of energy showed that the quantity and volume increased proportionately. While Hubble had the advantage of peering through an eyepiece to detect the distance related rate anomaly; the energy experimenters had the disadvantage of conducting only indirect measurements. For the physical parameters of energy- interactions were in the micro-dimensional region.



## Secret Of Sankhya: Acme Of Scientific Unification.

In a bid to find the limits of the energy radiation spectrum, ingenious procedures were used to find the answers. But the nemesis called contradiction turned up again! Contrary to expectations, instead of increasing proportionately, it collapsed at the highest energy level. It took the world of Physics by surprise. Not having found a solution, researchers named it the Boltzman paradox and the Ultraviolet catastrophe in deep space.

Later, Max Planck conjectured through complex mathematics that as energy was always being transmitted in packets, cups or quanta, the observed characteristics were to be expected. Thus Quantum Physics was born but another serious anomaly was making the process of measurement uncertain. Scientists found they could not verify the position while measuring the velocity of a particle. Next, when it was located, they could not measure its rate of motion simultaneously. This quandary had to be resolved quickly for the scientists were unsure as to where to search for the elusive particle or quantum. So they propounded, under compelling circumstances, the Principle of Uncertainty. It stated emphatically that a particle's 'position and movement cannot be measured simultaneously'. We are now squarely back to the starting point of our dialogue when it only implied that the Universe disappeared without an observer. Heisenburg's principle of uncertainty had now certified it as being correct and the scientific community had no way out of this dilemma.

Was it possible that in this solid and real looking Universe an observer could not detect something? Scientists did some serious introspection. Armed with a further string of fringe experiments under various names, showed that the particle or quantum disappeared only for a moment. Though it was impossible to confirm the location, it could be guessed with a tool called quantum statistics. By now, the scientific fraternity had travelled the intellectual road of

473

## Secret Of Sankhya: Acme Of Scientific Unification.

profound principles that started with the desire to be accurate and specific. But it had to be content with uncertainty and probability as key principles in Physics. Though credibility was at stake scientist refused to look for answers outside the laboratory environment. The reason was simple. Once it opened its doors to external principles, the logical continuity could become suspect and internal test for consistency broken. While theoretical science faced all the above intellectual hurdles, experimental science flourished, because a trial and error process led to concrete, usable results of some acceptable order. It was welcome, as in such a process one could not establish a theoretical goal initially. In this background, one can realise that acceptance of any alternate theory, however perfect, would meet with stiff resistance from the scientific community. For right now, all hopes are pinned on a theory based on 'super-symmetry' of 'super-strings'. What scientists were not aware of, the very source for all such theories was already lying hidden in a strange corner and defined in a stranger language.

### Science of the irrational

So far, one side of the coin, the rational observer from a protected elite, was analysed and conclusions arrived at. It left the state of scientific enquiry, into the fundamental cause of Universal phenomenon, in intellectual limbo. The other side of this coin entailed a research process more complex and confusing, called holistic perception. Like in science it was also a measuring process but of a different order. This investigative area was very large indeed. It had under its ken the entire range of phenomenon that rational scientists would not deign to touch. The identifiable spectrum covered telepathy, clairvoyance, and psychokinetic phenomenon, under the umbrella of a pseudo scientific term called ESP or extra sensory

474

## Secret Of Sankhya: Acme Of Scientific Unification.

perception. Then of course there was astrology; palmistry, numerology, iching and more, cleverly disguised through an ambivalent description like Oriental studies. It further extended to sensitive areas of unusual acts through divine intervention called miracles and manifestations. That had the silent and ambiguous approval of the respective religious pontiffs who automatically put a no-entry sign to an outside investigation. There were numerous fringe-events witnessed and confirmed by the lay public, like 'bleeding pictures' and 'milk-drinking idols'. Again, there were other events of oracular donkeys braying 'in' good fortune and mischievous poltergeist children breaking the neighbour's roof. Shamanistic performers exorcised ghosts and rural seers detected thieves through an oily betel leaf. Nimble fortune-tellers using seeds, sticks and shells divined the future while mystics made profound predictions from observing lizards, insects and birds. Voodoo, witchcraft, blackmagic and the list of possible ways to perceive holistically grew without bound.

What is more thought provoking is the fact that while the multitudes swore by these experiences, the stoic silence with which the scientific fraternity greeted such news was indeed astounding. It looked almost like they were from another planet where laboratory experimentation and complex mathematics ruled every inch of the way. Science stands for objective curiosity itself and yet scientists failed to display this basic trait towards an enigmatic area. Even plain curiosity could have paid significant dividends by discovering esoteric principles underlying such phenomenon. And no one can deny that phenomenon it is.

Early European society had geared itself to tackle science on an organised footing from a few hundred years back. Europeans considered this area to be their domain and preserve. Experimental inventiveness based on the need to survive a hostile environment paid rich dividends in

475

## Secret Of Sankhya: Acme Of Scientific Unification.

numerous ways and automatically established the proprietary status for its developments and products. The tropical and Eastern societies, on the other hand, continued with systems developed over long years of experience in surviving a more benign environment that was relatively stress free. The axiomatic Coriolis force endowed the tropical regions with the bounties of nature. It renewed, revived and recycled the environment in perfect harmony with nature's complex growth cycles. When nature itself played a decisive role in guiding their destinies into a state of effortless fulfilment it was no surprise that the incumbents in turn looked at natural phenomenon with wonder and reverence. That ultimately turned into divine worship. Their passive outlook and reverential attitude towards nature as an arbiter of natural and benevolent law gave them faith, courage and patience. They learned to await the cyclic changes with equanimity and optimism. Tropical inhabitants, world wide, type cast themselves into a mould of nature worshipers. They bent themselves to its will with utter submission. This was in stark contrast to the early European group who bent nature's forces to their will in a bid to survive the rigours of that location. A calamitous double fault in the precessional equinoctial-cycle had driven these settlers into this location. They overcame a calamity by innovative skill and a self-developed aggressive outlook. That gave them the experience to lead the world in the art of subjugating nature's forces. This very calamity yields the key to the diverse history of modern man on this planet. Plus the fact that a previous era had produced an intellectual solution to the puzzle of manifestation.

Nature's devotees in the tropics had already established the school for holistic investigation into natural phenomenon. It included the Mayas, Incas, Mexicans, Amerindians, Egyptians, Africans, Indians, Chinese, inhabitants of the Malaysian, Indonesian, Southsea island archipelagos, in  
476

## Secret Of Sankhya: Acme Of Scientific Unification.

short the dwellers of the tropics. They had diverse experience in the practice of the occult, mystic, magical, spiritual and a range of holistic practices in perceiving and understanding phenomenon. Unlike the scientific fraternity, this area functioned through a heterogeneous sprinkling of practitioners without a common platform of theory or principle. Most of their information, handed down from one generation to the next, made the process a subjective real-time affair. This group considered the observer and the observed were one, which eliminated the concept of measurement and its consequential collateral damage. It was recognised as a time evolved or axiomatic principle that the Universe was a real, experiencable, singular entity. So any artefact of mental or physical derivations could not separate out the observer from the observed. While the reality of the Universe as a factual entity was never in doubt, these investigators never attempted to establish a credible communication system. Such investigators experienced a feeling of certainty that prevented them questioning the acceptability of pedagogical descriptions and verbal definitions of complex events at face value. The possibility of variations in the choice of words and the structure of sentences in a pedagogical communication conveyed an air of inherent fuzziness. It made it difficult to extract the correct meaning. The consequence of this increasing gap in communication, not only marginalised them as a group from the scientific fraternity but split them further into smaller groups that battled among themselves for recognition. These investigators had unwittingly strangulated themselves with their own lack of communication principles. A few modern holistic investigators had attempted to establish a laboratory model infrastructure but the outcome had not found acceptance in the scientific fraternity. The laboratory type of observer / instrument/ observed type of divide could not be

## Secret Of Sankhya: Acme Of Scientific Unification.

introduced into holistic research where the researcher himself was the laboratory and his senses the instrument for observing himself. However in recent years Dr. Puharich, a dedicated researcher into psychic phenomena, spent almost a decade investigating Uri Gellers' psychokinetic acts. He observed Geller's performance under the supervision of Stanford Research Institute in the US, to establish scientific credibility. Despite confirmation of extraordinary psychokinetic acts, conducted under strict scientific supervision, there has been no reaction, except stony silence, from the ivory tower of Physics.

## The Cataclysm in the Vedas and its origin.

India, due to an historical advantage, took the lead in investigating holistic phenomenon. It included spiritual and yogic practices handed down ages ago from which it established a theoretical paradigm, based on disprovable axioms. While Physics had resorted to the unification paradigm to extricate itself from the intellectual mire of empirical science, the Indians based their thoughts on axiomatic principles that had the quality of unification built into it. These axiomatic, holistic principles formulated aeons ago, for all humanity, were the Vedas in Sanskrit. These were a sublime creation, not because it was from any divine source as the nature-devotees in the tropics naturally liked to claim, but its logical structure was immaculate, consistent and self proving, as it was based on numerical axioms. The concept of a divine origin for the Vedas had in support a number of circumstantial events that lead to this conjecture. The logical sequence of events leading to the needed background was cogently hypothesised through relevant mathematical adjuncts, by Lokmanya Tilak. He published the results of his meticulous research in his two classical books "The Orion"  
478

## Secret Of Sankhya: Acme Of Scientific Unification.

and "The Arctic Home in the Vedas". In it he hypothesised that a Vedic civilisations existed prior to the Glacial floods in the Arctic region. It had an equitable climate then due to certain precessional deviations in the planetary orbital cycles. Stating a truism, the historical memory of ancient events lingers in direct proportion to the calamitous level of collateral damage it invokes. One such event exists in all the profound writings and historical pronouncements of nations, countries, races, religious and ethnic groups of people, the unforgettable flood.

The glacial floods virtually destroyed all signs of human achievements or progress in the previous era. It left in its aftermath no relic of any importance that could have provided a handle of connectivity with civilisations that must have existed earlier. However, there is some confirmation through recent media reports of archaeological findings containing 40000-year-old human artefacts and implements in the Arctic Circle. Scientific corroboration of the glacial-melt causing the floods have been well established and documented to erase any doubts about its veracity. The glacial catastrophe occurred more than 10000 years ago. The survivors were certainly not the first-line of Homo sapiens so one had to believe they had forbears before the floods. A major reason for the historical haze surrounding pre-glacial man is this catastrophe. By wiping out any vestigial signs of an earlier civilisation, it eliminated the motive to look for evidence in currently developed areas. This uncertainty of origin was one of the reasons for a divine source for Vedic aphorisms.

The Vedas contained information in a language that was austere, cryptic and most unlike a primitive creation. For the verses structured on a rigorous metric interval, displayed the intellectual skill of its authors. Creating poetical compositions at the best of times required a huge vocabulary and a flexible flow of words to maintain a

479

## Secret Of Sankhya: Acme Of Scientific Unification.

rhythm. Resorting to this style of communication meant they were deliberately hamstringing themselves with the full knowledge that the process of information transfer would be made difficult. The normal question from this generation would be 'why would they take the difficult path', but it has an answer. They could not have created the unusually large number of verses, in the same style and format (ensuring the same origin), in the 4000-year interval after the flood. That is assuming evidence of Vedic creations was first exposed as late as 6000 years ago. Even today with all the advertising, publishing and other media marketing aids any serious literary creation fails to get wide acclaim in less than a couple of years. If we go back 1000 years, there exists no widely known physical evidence of the prevailing thoughts then except on stone. That at best can be the equivalent of a few hundred verses. Considering the logistics alone, of collecting tens of thousands of verses into one area, without an associated system, is well nigh impossible even in 6000 years. Soon after the floods, the only immediate concern of the survivors would have been 'how to survive' and not 'how to compose verse'. The Vedas could never have been composed after the floods for the intellectual content far surpasses even the knowledge of scientists today. Just a cursory inspection of a statistical growth-modelling algorithm gives about 12000 years for Vedic information in our possession.

On deeper analysis, one found that the clues in the Vedas itself were an unimpeachable source to proclaim its origin. It was indeed a veritable time capsule for modern man. Lokmanya Tilak, who sprang to the quick because of derogatory statements made by occidental translators of the Vedas, diligently sought out Vedic clues. The esoteric clues made him look at the most accurate clock in the Universe, the stellar sky. By a series of logical and meticulous analyses based on mathematical verification, he deduced the probable and possible date of Vedic creations,

480



## Secret Of Sankhya: Acme Of Scientific Unification.

after taking into account the dislocation caused by the glacial melt. He arrived at a possible 12000 years to a probable 20000 years for the intervening period. Then he found that the Vedic anomalies in the climatic, solar and stellar cycles were resolved by locating those ancient observers within the Arctic Circle. The variations in the cyclic precessional period of the equinoxes contributed to an uneven polar climatic cycle. (Vedic theory shows that the Solar system orbit in the Galaxy has an eccentricity value similar to planetary orbits.) The Lokmanya along with other geological scientists & colleagues from Europe calculated and established the range of temperature variations that would have been possible then. It showed that, in the cycle prior to the glacial floods, equitable temperature conditions would have prevailed for a long time in the Arctic, when human civilisation could have flourished. He found another fallout. The Zend-Avesta (Zoroastrian religious book) was indeed of the same origin as the Vedas. He discovered detailed confirmation for his hypothesis from the description of the then prevailing climatic conditions recorded in it. The succeeding generation of survivors, oblivious to their preglacial origin and being nature worshippers, naturally ascribed the Vedic aphorisms to a divine source and labelled it as a 'permanent' creation that was not of 'human origin'. But they did not realise that axiomatic creations too could be defined in the same way.

### Proof through Stellar positions and post glacial renaissance

Further, the passages in the Atharvaveda under the Nakshatradevatyam verses identified a sequence of precessional equinoctial coincidences beginning with the Nakshatra Punarvasu, the Vedic zero degree ecliptic position. The recorded coincidence could have only

## Secret Of Sankhya: Acme Of Scientific Unification.

occurred 32000 years ago for the immediate coincidence had taken place just 6000 years back. That was too short a period to rationally justify the quality and quantity of Vedic creations. The fact of its mention is verifiable evidence, which confirms the observation of those stellar sequences by ancient witnesses. It provided an acceptable connectivity to their period of development. Their pinpointing the ecliptic crossing in the Nakshatra Magha when the floods would have taken place acts as additional evidence. Another puzzling factor that adds conviction is the question 'how could they know to accurately calculate precessional cycles when knowledge of this inertial process was a post Newtonian event'. A more precise proof exists in their choice of twenty-eight Nakshatra positions to describe the precessional progress. The number came from an advanced scientific theory mentioned below. In it, a circle contains twenty-eight axiomatic sectors of a coherent state, instead of the arbitrary and primitive 360-degree division in postglacial thought. Notwithstanding these clues, there is another scientific evidence that confirms by default. The answer as to why they created the verses in rigorous metrical framework became clear when the present writer decoded, through the Siddhi process, the first and grandest sloka in the Rigveda. The sloka "*agnimile purohitum yajnasya devamritvajam hotaram ratnadhatamam*" turned out to be an extraordinary theorem on extraction of energy from space by triggering it into an expansive state. Surprisingly the composer had built-in the proving answer to this theorem as a numerical code wherein each letter stood for a number value. The number, precise to the third decimal place after dimensional conversions, was equal to the modern value of a relative volume of light or Electro magnetic wave formed in one second. That information provided the motivation to invent, test and demonstrate a free energy electric motor. Its novelty lay in the fact that it violated Faraday / Maxwell electromagnetic laws, as it had

## Secret Of Sankhya: Acme Of Scientific Unification.

no magnetic field. It not only worked but also displayed free energy or over-unity efficiency characteristics. This is a singularly effective proof of Vedic excellence in scientific knowledge. The writer and his eldest son demonstrated the motor and explained its principle of operation, outside the known electrical laws, at the Gravitation Energy Conference in Hanover in 1986. The details of the motor were published in the Indian Express on 24<sup>th</sup>. Nov. 1987.

How could the Vedic forefathers have known all this unless they had cracked the scientific codes of nature? There is an excellent reason given further below. However, a little digression will lay the correct foundation to show the contrast between the two systems of scientific analysis. Briefly tracing the 10000-year diary of human renaissance, after the floods, leads to some hypothetical conclusions. It also offers a logical explanation to many conjectured 'facts' of history. The survivors from the Arctic Region turned southward, into Europe, Asia Minor, Persia and India. The present European stock took the path of confrontation to battle out the climatic conditions in Europe, and as described earlier, managed to survive the rigours of that region. They overcame nature's hurdles by sheer will through a range of adhoc innovations that European history extolled proudly. The fact that the origin of all white populations anywhere in the world today leads back to Europe provides a signal confirmation to that hypothesis. The Asiaminor visitors not harassed by the weather gods continued to survive comfortably until a spontaneous genetic re-awakening drove them into intellectual and philosophical innovations. That has produced the only two monotheistic disciplines of Christianity and Islam in one area, almost at the same time, relatively speaking. The older form of Judaism historically had a part to play during the floods but later, it probably influenced the newer theism. It is very indicative that all these theistic disciplines have holistic perception, as the

483

## Secret Of Sankhya: Acme Of Scientific Unification.

base for its spiritual practises. That cannot be a mere coincidence for they are very divergent in their religious goals.

The settlers in Persia and India brought with them the relics of the glacial melt in an unusual form. It was a complete system that 'developed, maintained and practised' the natural laws of Universal manifestation based on axioms, as a continuous and continuing process. The preglacial ritualistic practice of repeating the memorised verses daily from the age of seven onwards under the tutelage of Gurus or holistic teachers of different schools, ensured the continued transfer of all the informative verses to successive generations. Instead of creating books, they created a 'human information' memory bank. This living library, based on the genetic propensities of the individual, trimmed, trained and honed to perfection by the specific sage as Guru for each discipline, transmitted knowledge to the next generation. It produced the most effective instrument for transferring knowledge to their next of kin through a human memory bank based on genetic lineage or Gothra. The Gothra system was linked to stellar positions, or Nakshatras, based on axiomatic facts of genetic propensities. The Vedic system of composing verse for oral transmission was a superior form of communication compared to processes that depended on scripts. Its perfection also lay in the construction of memorable phrases, each letter of which, stood for a numerical value. Hence, they were able to transmit even 25 decimal-place-numbers without error. Trained in meditative practices the students became adept in each discipline that needed no pen or paper. The written structure of Sanskrit developed much later by postglacial survivors, was a primitive and incomplete effort at preserving those Vedic verses. The nth generation survivors seemed to have forgotten, the six built in factors for oral communication, (mentioned in the first para,) that

484

## Secret Of Sankhya: Acme Of Scientific Unification.

a meditative Siddhi process needed. This fact is glaringly evident in some modern translations of two adjacent verses in a set. Often it shows no connection between the two whatsoever. But as every meditator knows one can extract the true meaning of a set only when all its related verses are held simultaneously in a state of contemplation or Dhyana

An effective preglacial system that had continued for ages survived the cataclysmic event by the sheer momentum of past practices spread widely. The relatively few survivors were able to regurgitate their memorised knowledge without a break. It ensured the complete revival and renaissance of Vedic knowledge. That, ostensibly, was one reason why this group lacked motivation to re-invent religious, philosophical or scientific systems. Vedic scientific knowledge was epitomised in one preglacial creation the Bhagavadgita. It had for its axiomatic core, the creation by an intellectual colossus Maharishi Kapila, the Sankhyayoga. The unforgettable & dramatisable background creation, the Mahabharatha had both the Bhagavadgita with the imbedded Sankhyayoga as its scientific and philosophic foundation. To appreciate the sheer ingenuity involved in creating this information transfer process one must realise it targeted three groups simultaneously. While Sankhyayoga (Sankhya) or the theory of counting as Jnanayoga focussed on the rational intellectual, the Bhagavadgita provided the philosophic meaning through a pedagogic dialogue between the personalities of Sri Krishna and Arjuna as Bhaktiyoga. And finally at the lay public through the most vibrant and unforgettable setting of a battlefield background with the possibility of dramatising every event in the manifestation process as Karmayoga. It was not a religion but an axiomatic science that practised its laws holistically and ritually which eventually gained a religious equation. It was an elite concept of practising axiomatic laws called

485

## Secret Of Sankhya: Acme Of Scientific Unification.

Dharma. The theory based entirely on axioms had eternal validity. For one cannot disprove an axiom.

Above all, it was a system practised by the preglacial forefathers and an accident of nature left it as a relic to postglacial man. The 54<sup>th</sup>. verse in Sankhya gives a circumstantial clue to its origin. The range of manifestation is defined as 'brahma' at one limit and 'stamba' or fixed-point as the other. This definition can never have been created in the postglacial scenario. For Brahma, here, is a revered, pivotal deity, whereas brahma was a technical term for the field of cosmic space in the earlier era. Modern translators must realise that Vedas in verse was not meant for this generation just as we know that Physics today is not aimed at a civilisation surviving a holocaust. Additionally, a telling fact to ponder over is that how and why did the re-writers of Veda and Avesta cover the same process and period, in two different scripts, at about the same time, if they knew of their origin? Again, why was there later, a proliferation-of-re-interpretations as Bhuddism, Jainism, Vaishnavism, Saivism, Vashistadvaitism etc if it were not a clear indication of dissatisfaction in understanding the preglacial gift? Maxmuller, under the firm impression that the Vedas were a superior form of polytheism, classified it as a henotheistic system, a subordinate to his ideal, the monotheistic religion. His dogmatic views in fact set the pace for mutilating Vedic translations by modern research workers. Despite the foregoing pedagogy, what follows is clinching proof, for the mathematical contents and scientific concepts in this axiomatic theory could never, never have come even from today's scientific elite, let alone post glacial man. The surprise of surprises lies in this ancient treatise, the Holy Grail of unification, that exposes the error in a so-called axiomatic constant of GR that shot Einstein into scientific fame. Therefore, there cannot be any doubt that the Mahabharatha, Bhagavadgita and its

486

## Secret Of Sankhya: Acme Of Scientific Unification.

core, the Sankhyayoga, belong to the same period and considering its extraordinary scientific content, as shown below, it certainly cannot be of postglacial origin. The confidence, that this theory is precise and correct, comes only from the fact that its numerical parameters match those of Physics with a better-than-acceptable order of accuracy. These comparative numbers are shown below in a tabulated form.

### The axiomatic and unified theory of Sankhya

What did Maharishi Kapila propound in the Sankhyayoga (Sankhya) that entitled it to be the core of the Bhagavadgita? It is highly indicative that in chapter 10, verse 26, Sri Krishna identifies himself with Muni Kapila as the master of Siddhi. Sankhya is not only mentioned by name in the second chapter verse 39, but its heading is Sankhyayoga, as an introduction to the most profound philosophy on which the subsequent dialogues proceed. Its importance is doubly certified as the principles of Sankhya are mentioned several times in almost every chapter. Maharishi Kapila created 68 sets of verses (total 70) or Suthras (theorems of logic), each of which contained a proposition and its solution that explained the entire manifestation process of the Universe. While it is well nigh impossible to do justice to this extraordinary theory in this short expose, this brief highlight of its axiomatic principles will be shown as a lesson in logic.

1. The first verse, which had the starting proposition as a query, also contained a conditional solution. The test for its acceptability depended on the correctness of subsequent solutions. It was an intelligent way to connect all the propositions rigorously to the first solution. The method of elliptical negation provided logical internal proof. Even today, Physics would not impose such a constraint for it cannot unify even one set of forces.

## Secret Of Sankhya: Acme Of Scientific Unification.

2. It was based on numerical axioms, which cannot be disproved and was valid for all times. No theory in science is based on numerical axioms as of today.
3. The entire mathematical process involved only counting. Sir Roger Penrose, author of twister theory, foresaw that a correct theory could only be based on some principle of combinatorial counting.
4. Sankhya theory is based on starting from a clean slate. Physics was started right in the middle from experimental inputs that became empirical and so has tremendous complications for it to find its clean slate.
5. All manifestation processes were defined by one type of event and that was an interaction in three modes. Science today has a variety of definitions, like mass, momentum, acceleration, energy etc, except quantum theory which counts the rate of phenomenon, based on the Planck's constant. It is the closest to Sankhya principles.
6. The first interaction can axiomatically be only between the first two objects. So all the laws of interaction must be completely derived within the very first interaction. Physics having started in the middle has a very long way to go before it can define the first interaction.
7. All counts of interactions were always a ratio between one set and another similar unit, so that dimensionality of the interacting objects cancelled out and only a pure relational and dimensionless number formed the solution. The unit 1 in Sankhya is a ratio of infinity upon infinity. This is an important feature in science for keeping account of dimensionality, which complicates Physics to ridiculous levels.
8. Since only interactions were to be counted, all manifestation consisted only of oscillations or vibrations. In terms of a scientific concept, it meant that Sankhya treated the Universe as a vibrating hologram (spirituality or ethereal vibrations in lay equivalence). It was either changing its state by transmigration of stresses or oscillated



## Secret Of Sankhya: Acme Of Scientific Unification.

in the same location as a frozen hologram. It is an advanced concept that removes all the anomalies in Physics mentioned in the second paragraph.

9. Interactions took place in 3 Guna modes namely simultaneous, resonant and radiant states. The equivalent in Physics is the inelastic or Thaama, elastic or Sathwa and weak interactive force or Raja. The three Sankhya modes dealt only with time cycle variations as a counting procedure. Logically in a dynamic theory cyclic time was the true variable, for Sankhyan space being real and substantial, could not vary.

10. Space as the foundation of the Cosmos or Universe was described only by the relative interactive qualities needed to sustain manifestation and ensured that only the process of counting interactions was used to account for its balanced state. From the scientific point of view it was not necessary to consider the quality of space or its contents and showed that Sankhya was a relativistic theory.

11. Manifestation is self-similar and scale-invariant. This allows the same formulation to be applied mathematically to define the Universe, Galaxy, Sun, Nucleon, Electron or any particulate state through one constant parameter. Physics, not being scale invariant, needs at least three parameters and they are not constants.

12. The fundamental field of space in Sankhya is mathematically defined in Sanskrit as Aikanta (coherent or frozen as a single entity), Athyantha (without end-perpetual), Atho (dynamic) and Abhavath (unmanifest or balanced). Physics cannot define space as it is classified as a vacuum.

13. The holographic mode of manifestation is proved mathematically by showing that all phenomenon is bound simultaneously by a spectrum of seven states and released sequentially be one mode. The enigma in science, why sound, light, particulate, molecular, atomic, nuclear and

## Secret Of Sankhya: Acme Of Scientific Unification.

sub-particle level have a periodicity spectrum, is resolved axiomatically.

The above parameters are some of the 'easy to understand' aspects that differed from Physics. The mathematical aspects of this theory are all encompassing, profound and complete in all respects. The unified solutions are derived internally and matched accurately to provide numerical answers to every known and unknown stable parameter in Physics and Cosmology. It has its own system of internal proof by matching six alternate derivations to 25 decimal places. Sankhya enables the tabulation of the entire Cosmic manifestation parameters similar to any mathematical log table or almanac, with the certainty there will be no phenomena found falling outside it. This aspect is not possible in science today. How do we know Sankhya is right? Differentiating the Sankhya-derived-mass of the Universe by its smallest displacement leaves a precise single unit-angular displacement value of the very first interaction. Such accuracy is possible only in the realm of the divine! Sankhya also gives equally accurate numerical solutions to both scientific and holistic problems in phenomenon. The latter process by itself is an extraordinary confirmation of Sankhyan supremacy, for science has deliberately closed its eyes to it and actually believes holistic perception does not exist!

### An overview of Sankhya axiomatic principles in relation to Physics.

An outstanding feature of Sankhya is that no measured or empirical inputs are required and the axiomatic theory starts by manipulating the interactions between two objects in various ways. Explaining briefly, Sankhya is based on counting only oscillatory interactions as a ratio of a standard & axiomatic cycle of 10 counts which are 490

## Secret Of Sankhya: Acme Of Scientific Unification.

dimensionless, scale-invariant, coherent, synchronous, reflection invariant and symmetric. Though space has substantial qualities identified as the Purusha State, it cancels out, as all measurements are relative comparisons through its smallest unit the Moolaprakriti. So the Purusha's basic qualities are not mathematically relevant in defining phenomenon. Any Sankhya equation is always the algebraic sum of three Gunas as Thaama (strong force), Raja (weak force and gravity) and Sathwa (Electromagnetic force) or a ratio of Thaama / (Raja into Sathwa.). Hence, all equations compare only three real dimensions. There are three cyclic states to define time and are governed by three principles, Simultaneity, Self-similarity and Relativity and these have scalar (full force), tensor (stress dependant force) and vector (time dependant force) characteristics respectively. All of space is always in a dynamic oscillatory state, at an axiomatic rate of 296575967 oscillations per cycle of 10 oscillations or 299792458 oscillations at a metre wavelength / second, which equals the velocity of light in vacuum. The extraordinary fallout from deriving the holographic oscillatory state is that it corrects velocity of light in Physics relativistically by the solar orbital velocity in the Galaxy by the factor 1.010845. Michelson & Morley detected this corrected value but no one realised that it was relevant and thought the experiments failed! Their results displayed a Doppler blue shift in frequency. Hence, the frequency of light in the Solar system cannot be constant. It automatically explains the cause of global warming, which in fact led to the glacial catastrophe.

The Sankhya division of interactive states is shown only to compare values in Physics. It is shown in a simple and generalised way to make it understandable to non-scientists. The reader's attention is drawn to this fact that in Physics all values have been measured whereas in Sankhya all values are calculated from axiomatic variations of the numeral two and that principle was evolved more

491

Secret Of Sankhya: Acme Of Scientific Unification.

than 12000 rears ago. Despite that, the difference is extremely small. All numbers are interactive count rate per self-similar cycle. Where dimensional values are given for comparison, the Metre-Kilogram-Second system is used with unit time as 1.010845 seconds, due to the relativistic shift from the solar orbital velocity. Values in Sankhya being axiomatic derivations it can never change. (B=Billion. L=Light. Y=Years. M = Mega. G = Giga). Numbers shown with like 10e+6 means it has 6 zeroes or the real value is a million counts. Or 10e-6 means it has 6 decimal places or  $1/1000000^{\text{th}} = 0.000001$ .

Sankhya Stable states. Equivalent in Physics shown in last column.

Purusha	Andhatamis hra state	Max Mass in Blackhole state	No equivalent in Physics
Prakriti Mahat	Moha state	Max Mass in coherent state	Hadron- quark domain
Prakriti Sapta	Maha Moha state	Max Mass in resonant state	Hadron- Nuclear domain
Vikriti Mahat	Moha state	Min Mass in coherent state	Lepton- Electron
Vikriti Sapta	Maha Moha state	Min Mass in resonant state	Lepton- Neutrino
Moolapra kriti	Vikaro state	Min Mass in transmigratory state	No Equivalent

Interactive qualities in a cycle (Not identified in Physics)

Principles of Yuga	Yugapac- Simultaneity	Swabhava- Self-Similar	Kramasa- Relativity
Yuga -Time Cycle	Instantaneous- Spacelike	Resonant - transmigant	Sequential- Time like
Sargah Int.	Abhiman -(self	Tensor	Ahankar

Secret Of Sankhya: Acme Of Scientific Unification.

creation	potential)	interaction	(acceleration).
Sargah- Ext.creation	Linga- Mass	Vector interaction	Bhava- Charge

Stable Mass particles compared to Planck's constant as energy value

Name	counts	Physics	S'nkhya	GEV	Equiv:
Purusha	10e+50	None	0.9149 kgs	5.133e+2 6 GEV	None
Prakriti Mahat	50-8 =10e+4 2	2.177e- 8 kgs	2.203e- 8 kgs	1.236e+1 9 GEV	Planckm ass
Prakriti Sapta	50- 25=10e +25	1.672e- 27 kgs	1.675e- 27 kgs	0.93927 GEV	Proton
Vikriti Mahat	50- 28=10e +22	9.109e- 31 kgs	9.11 e- 31 kgs	0.511 MEV	Electron
Vikriti Spectra	2π 10e+ 17	6.626e- 34 (Joules/ sec)	6.7e-34 counts/ sec)	53.45 EV x 7 (7 neutrinos )	Planksco nstant. As energy unit
Vikriti Sapta	50- 33=10e +17	None	9.53e- 35 kgs	53.45 EV	Neutrino
Moolapr akriti	1 count	None	1.344e- 51 kgs	7.543 e- 16 EV	None

Secret Of Sankhya: Acme Of Scientific Unification.

Secret Of Sankhya: Acme Of Scientific Unification.

Comparison of axiomatic Sankhya and Einstein's cosmic concepts.

Observations in Universe	Sankhya-derived	Einstein - Estimated	Error in Physics
Radius Maximum	19.26 B. L. Y always	18.84 B. L. Y	Time cycle
Time cycle	30.64 B. Y always	29.76 B. Y	Time cycle
Radius Today	12.8 B. L. Y always	13.19 B. L. Y	Time cycle
Hubble expansion rate (conceptual error)	6.283e+17 Change in Entropy of space	Megaparsec / 49000 = 6.23e+17	Concept of Space
Critical Closure Density	3.63e-25 kgs/m <sup>3</sup> always	1.48e-26 kgs/m <sup>3</sup>	Error 8 Pi
Expanded Envelope	1.5e78 m <sup>3</sup> always	3.83e+79 m <sup>3</sup>	Error 8 Pi
Mass of Universe	7.8e +52 kgs.	5.68e+53 kgs	Error 7
Radius of Universe	5.99e +25m	1.236e +26m	Error 6/Pi

Secret Of Sankhya: Acme Of Scientific Unification.

Classification of Sankhya Holographic states in counts per cycle.  
Class in Physics

Class	Thaama (Compress )	Raja (Interactive )	Sathwa (Expand)	Spectrum
Total counts 10e+50	10e+28 Entropy	Interactive Flux	10e+22 radiation	
Coherence( Thaamasic)		3 axis synchronise d		Singularit y
Andhatamis ra	10e+8 Blackhole	28-8 =10e+20		Blackhole
Prakriti mahat		2 axis Synchronis ed	Coherent Limit	Planck mass
Moha	10e+10 Coherent	20- 10=10e+10		Heavy Quark
Mahamoha	10e+10 Resonant	10 - 3 (axis)=10e +7		Quark
Interactive balance		Spherical Flux 3 axis		Strong
Prakriti Sapta	22 +3=10e+ 25	22+3=10e +25		Hadronic
(Rajasic)	Interlocke d mode	Area Flux 2 axis	Resonant Limit	Bosonic
Abhiman		8+3=10e+ 11		Phase potential
Ahankar		8-3=10e+5		Phase velocity
Linga		9-3=10e+6		Magnetic
Bhava		9- 3x2=10e+3		Electric



Secret Of Sankhya: Acme Of Scientific Unification.

(Satwic)		Radial flux 1 axis	Radiant Limit	5.133e+2 6 GEV
Vikriti Mahat/Sapta	25-3 =10e+ 22	20+5=25 25-3=22	10e+5	1.236e+1 9 GEV
Tusti internal	10e+20	16+4=10e +20	10e+4	0.93927 GEV
Vikaro	10e+16	3+13=10e +16	10e+3	0.511 M EV
Tusti external	10e+13	16- 3=10e+13	10e+5	53.45 EV x 7
Siddhi	10e+8	13- 5=10e+8	10e+8	53.45 EV
Moolaprakr iti	1	1	1	7.543 e- 16 EV

There are a host of related parameters that will be published later in the author's book the 'Secrets of Sankhya' along with an accurate scientific comparison that puts Sankhya on the pedestal of 'Theory of Everything'. Coming to the major anomaly of the 9-cup loss during measurement, that started the train of redemptive principles in Physics, Sankhya solved it most elegantly. Recall that the blind man held the measuring cup for one clock second, as he could not detect the completion of this process. Sankhya principles axiomatically derived the smallest measuring cup with the fastest filling rate of seven-cups-at-a-time and stopped filling automatically because the potential difference became zero! Then there was no loss at all for the observer just counted the cups, as and when he took them. Now his measurement would always tally, with what he took and what was left, as he could never be faster unless he filled more than 7 cups at a time. The axiomatic spectral characteristics forbade exceeding 7 states. In plain language, if one immersed the flattest measuring cup just below the water level, it fulfilled

497

## Secret Of Sankhya: Acme Of Scientific Unification.

those conditions. Scientists should 'see' that process as the interactive flux transfer rate in a blackhole or frozen hologram, confirming Hawking's diction that its surface area can never decrease. The proof (shown in table above) is that even the much larger Planck's constant is also equal to seven Neutrino masses acting simultaneously as a photon in a radiant spectrum!

Why did not scientists arrive at a similar conclusion? There were two major reasons. Planck calculated the value of the quantum by evaluating experiments that measured black body radiation to simulate a balanced state. He evaluated radiant quanta in transmigratory motion and concluded that was its final value. According to Sankhya, it was the equivalent of the quanta in the radiant mode of an interaction. But a quantum at "rest", the Moolaprakriti, interacted in the simultaneous or frozen mode of a blackhole and its value was very different. It was  $10e+17$  times smaller or it was equal to one unit of change in the entropy of a tiny blackhole that Sankhya has identified in every point in space. Such a small unit of measure hidden in the Planck energy scale caused the uncertainty in measurements, value of matter density, particle wave duality and the enigmatic Planckian fluctuations. It is indeed close to the Cosmological constant that Einstein threw out as his blunder. Only when a fluctuation exceeded a change in entropy equivalent to  $10e+17$ , it radiated a photon. So this huge energy reservoir was hidden. Hubble detected this delay and misread it as an expansion, for logically the unit rate of change in entropy will take place only at the very end of an interactive radiant cycle or  $10e+17$  metres away.

The numerical proof for this fact comes from the enigmatic 2.7 degree Kelvin background temperature in space that Peebles et al recorded. The  $10e+17$  modes of change in entropy in a micro blackhole in space logarithmically equals the natural log value of  $e = 2.718$  or 498

## Secret Of Sankhya: Acme Of Scientific Unification.

the total sum of self-similar change in volume per cycle. Mathematically it could never exceed 2.718. Hawking et al exposed the entropy value but as a macro blackhole phenomenon on a solar scale, for science was apparently unaware of the concept of scale invariance and reflection symmetry in a frozen hologram. So a tiny blackhole is no different from a massive blackhole except for its self-similar time cycle. As a simple example if ten people clap one after another the ten sequentially related claps could be counted as 'ten claps' but if all ten clapped simultaneously only 'one dense clap' would be counted. It described charge and mass concepts respectively in a holographic world. Secondly, the concept of energy to define phenomenon in space was incorrect. The frozen mass quanta or Moolaprakriti mass vibrating in the same location of space as a coherent hologram had not been taken into account. It provided the missing darkmatter-mass value (that cosmologists were searching for) as Planckian fluctuations. Another serious error had occurred in Physics. Interactions always act in a straight line and that is an axiom. Hence, there can be no curvature inherent in any fundamental interaction. Only the loci of a sequence of interactions looked curved but Reimann & Gauss geometry made it a fundamental characteristic of space. Einstein used it as the basis for GR, which introduced the erroneous axiomatic constant  $8 \text{ Pi}$ . Because of the foregoing anomaly, Einstein desisted from defining a singularity. For his problem was in defining the boundary of a point! Opening out  $8 \text{ Pi}$  through self-similar mathematics of the Sankhyan Andhatamisra domain displayed the hidden entropy spectrum in all its glory, as shown in the tables above. That concept was the very stroke of a genius, Maharishi Kapila, the veritable intellectual colossus of a preglacial era.

While laboratory instruments emulated all the five senses, it could not imitate natures' own instrument the brain,

499

## Secret Of Sankhya: Acme Of Scientific Unification.

which was the core that maintained all forms of life. Sankhya proves that the two halves of the cerebral system were a sensory signal multiplexing instrument, Buddhi and Siddhi, based on the same interactive Guna qualities of space. It was indeed the most magnificent instrument to detect a null current or equi-potential state. The brain, detecting the Moolaprakriti stress currents as an imbalance in the potential of the two cerebral lobes, transmitted its difference through the (eye of wisdom) pineal gland to the Mooladhar or the lower spinal plexus that magnified it. It was an experiencable signal, the much spoken about Kundalini current. On receiving a human query, the two unbalanced cerebral lobes went on a furious search till they reached the balancing point of a null Moolaprakriti current. On receiving that answer, the human gave a sigh of relief, demonstrating his utter satisfaction. That process signified the symbolic 'OM' state. It was epitomised in Patanjali's Yoga Suthras. All holistic phenomenon like ESP, astrology, miracle and manifestation that seemed irrational was due to the Moolaprakriti surge. It was caused by a phaseshift or 'twist in space' that had not yet become an identifiable Vritti or photon. It resulted in a momentary scalar force whose origins were not detectable. The unvarying shape of the lunar and solar tidal envelope around the earth is a further witness to the Moolaprakriti surge. Hence no instrument based on measuring an energy differential could detect a change in the phase shift of a potential. Aharanov and Bohm proved this point through experiments. But every cerebral system based on genetic cells in man, animal or plant could detect it, as a change in feeling, mood or physical state. Backster proved this aspect through experiments on plants and it is known as the 'Backster effect'. Especially, more so for man, when he was in the null or balanced Theta brain wave state of 3.75 cycles per second in deep meditation. The Maharishi Mahesh Yogi's students bounced 'crossed-legged' along a

## Secret Of Sankhya: Acme Of Scientific Unification.

laid out demonstration course, in full view of the public, in the Theta or Siddhi-state. Ayurveda operated through the same Guna laws but applied to 'genetic-molecules' as Vata, Pitta and Kapha, synonymous with Sathwa, Raja and Thaama states respectively.

As everything was affected by the ever-present stellar Moolaprakriti stress transmigration currents astrology played an important part in influencing the trends in all interactive aspect of genetic matter. Maharishi Kapila, through his holographic theory, gave a mathematical basis to understand one of the most enigmatic concepts that pervade all religions. The concept of the human soul and its consequence was the interaction of a resonant hologram that acted according to the principles of the three Gunas. Epitomised as the (field theory) Kshetrajna of (actions) Karma in the Bhagavadgita, it followed the same axiomatic laws of a Vritti or photon but in its own time cycle. Dr. Moody had published accounts of 'near-death-experiences' of over 2000 people that were nothing but a refusal of such wandering holograms to disintegrate on those occasions. Sri Krishna tells Arjuna the same fact that those he hesitated to slay were already dead as their holograms had lived out its time then! The Hughes Drever experiments did detect the Moolaprakriti stress transmigration current in space but was declared an instrument noise by wise scientists. Such a current removed the need to propound the Principle of Equivalence, as there was only one stress current in space. It acted as gravitation, electromagnetic, weak, strong forces or as phase-shifts in the quark and blackhole domains, depending on cycle time. The foregoing theory could never, repeat never, have come from even today's citadels of Physics and Cosmology, let alone postglacial man, unless one resurrected the 'Vedic divine origin' aspect again. In this extraordinary background, the Lokmanya's

501

## Secret Of Sankhya: Acme Of Scientific Unification.

hypothesis based on meticulous research becomes very relevant.

As pointed out earlier, the scientific peerdom will be the one major obstacle to a smooth and effective transfer of this axiomatic science of Dharma to the public domain. Because current Physics and Cosmology will be reluctant to switch over to a holographic, dimensionless, scale-invariant, reflection-invariant theory, in a space that is certainly not a vacuum. Moreover introducing axiomatic principles into the laboratory domain will be like setting the cat among the pigeons. That would automatically remove the principles that glossed over anomalies and place theoretical science on the back burner. An undesirable synthesis, for the left-brain 'rationalists' of science, would be the need to work with so called right brain 'irrationalists'. For in this axiomatic and holistic science the invisible part of space takes on an unimaginable share of importance. Then experts in handling psychokinetic phenomenon like the Sathya Saibaba or Uri geller could help holistic science quantum leap into new frontiers. For instance, as early as 1930, both Annie Beasant and Leadbeater published accurate sketches, in minute detail, of 92 atomic elements in the periodic table by 'seeing them visually' in a meditative state. But nobody believed it for 50 years till Dr. Phillips confirmed it his book recently. Over a period of years, Peter Hurkos helped the Dutch police to solve complex crimes through clairvoyant vision. The holographic background gives a new twist to astrology, much against the so-called rationalistic view. It affects every phase of predicting organic or inorganic phenomena, like earthquakes, stratospheric twitching, cosmic ray showers and a host of things too large to mention here. And that is because the concept of Gravity as a force is too large a tool to detect the microscopic Moolaprakriti rumblings in the same gravitational field. In fact, numerous people have

502

## Secret Of Sankhya: Acme Of Scientific Unification.

reported experiencing headaches before an earthquake. Animal and birds have been seen to flee the area before such an event. Instead of instrumentally imitating, the cerebral functions, a new cadre of holistic scientists, may have to evolve in order to attain speedy results, as developments in this area need not be of the existing pattern at all.

For instance the entire information technology spectrum can switch over to an organic, genetic recombinant 'hardware' that grows, maintains and renews like any living system, operating on self generated low voltage organic D.C. power systems. It could also do parallel processing of information when demanded. There could be a revolution in power generation concepts through the production of 'fuel-less-power' direct from space. For, the hidden coherent gravitation field itself is capable of yielding unlimited supply of both electrical and mechanical power as elucidated through Sankhya principles. The work of the scientific genius Tesla, is a case to point, in that area of field-energy mechanics. Next, the mechanism for initiating cold fusion will be made easy when scientists understand the new Sankhya principle of 'simultaneity', the governing theory for all dynamic coherent states. There is no evidence, in Physics even today, of a self-similar mathematics regime that operates in the 'simultaneous interactive' regions with precision. Hawking, in one of his lectures bemoaned the inadequacy of the Schroedinger equation (to solve blackhole problems), the only simple mathematical tool available in this spectrum.

The principle of self-similarity, embodied in the three Gunas, is symbolically represented by a bow. Forces of compression in the arch as a vector and tension in the string as a tensor are in balance simultaneously. When an arrow was shot it represented a scalar force and what the Schroedinger equation calculated was the depth of penetration in the target! No doubt Hawking lamented its

503

## Secret Of Sankhya: Acme Of Scientific Unification.

limitations for Maharishi Kapila's Moolaprakriti measured the vibrating rate of the string before the arrow was shot! Arjuna, the archer, was a master of the symbolic Gunas in the Gita, while Sri Krishna was the ultimate architect of the unified science of Dharma in the Universe. The 69<sup>th</sup> Suthra states that Sankhya is a secret or coded creation and apparently not meant for open circulation. Hence, there is the danger that, while such scientific development could flourish in the benign countries, misuse of fundamental knowledge in the hands of unscrupulous groups could produce disastrous effects. For the key to fusion energy, genetic recombinant technology, quantum information-decoherence-entanglement-avalanche phenomenon and ESP subliminal-information-transfer, are areas, among countless other possibilities, that could make the earth a veritable hell to live in if misused by mindless rulers.

Finally, the creation of Sankhyayoga by Maharishi Kapila is invaluable on three counts. Sankhya unified the two concepts of science and religion by demonstrating its equivalence through axiomatic laws.

Accepting the fact that cosmic laws must remain the same with or without an observer, every human being should have been able to understand it in an identical way. But driven by their innate genetic Guna-qualities (shown below) people polarised broadly into two groups with rationalistic (scientific) and holistic (religious) preferences. The prevailing view was that science, based on a sequential logic starting from an empirical source-level, described phenomena effectively. However, scientists rationalised that theistic principles, on the other hand, pre-empted the scientific analytical process by identifying a timeless and powerful creator as the initiating cause. Supporters of religious dogma argued that scientific analysis was matter-oriented, temporal and ignored the eternal aspects of reality. But Maharishi Kapila's theory elegantly pointed out that an arbitrary source-level in science or the

504



## Secret Of Sankhya: Acme Of Scientific Unification.

enigmatically powerful creator in religion could both be conceptually replaced by an axiomatic source-law of nature called Dharma. Axioms are not created for they are always there as a pure relationship of two numerical variables. As is well known axioms cannot be disproved and are therefore valid eternally to all humanity. This fact automatically endowed it with the mantle of divinity and so it logically satisfied the fundamental precepts of eternity in religion. The goal of scientists too has always been to base scientific theories on axioms, to eliminate the uncertainty at its source-level. The intellectual magnificence of Maharishi Kapila showed through exquisite mathematics that this very axiomatic source had the power of the most powerful creator that man or any observer could ever conceptualise. Since Sankhya derived the ultimate Purusha state purely through axioms, where was the reason for science and religion to differ? For all their core, requirements of a powerful, eternal and logical source were fulfilled beyond all human expectations (Physics has yet to discover the Purusha state of coherent power. Its value is shown in the tables above).

2. Maharishi Kapila unified the two contentious concepts of materiality and spirituality by demonstrating through precise mathematics that all manifestation was a hologram or the very embodiment of spirituality. He underscored the fact that one cannot have spirituous vibrations without interactive matter, which was the core-Guna-theme in the Bhagavadgita.

The 50 verses in chapter 13 in the Bhagavadgita gave an exhaustive pedagogic explanation of the field concept or Kshetra comprising the Brahmanda or field of cosmic space. Maharishi Kapila showed unequivocally that what an observer detected was only a vibration from an interaction between two objects. Present day Physics too has confirmed that everything in this Universe is composed of vibratory or oscillatory components, be it

505

## Secret Of Sankhya: Acme Of Scientific Unification.

solid or evanescent. Through the three Guna interactive modes (explained earlier), Sankhya shows (through Suthras 3 and 46) with utmost numerical clarity that the solid, massive and static Purusha state of ultimate power is only composed of the lightest Moolaprakriti vibratory state. But there are  $10^{50}$  Moolaprakriti units (shown in the table above) interacting simultaneously in the Purusha state. That unimaginable number acting simultaneously contributes to the impression of solidity. The field of molecules we call air can be blown away easily by us but the same air in a tornado blows away our very homes, displaying a hidden factor of solidity that could never have been conceptualised. It is just the simple molecule of air acting simultaneously as a group. Sankhya mathematics shows that tornado represents a moving hologram called Vritti. The Purusha and the Moolaprakriti are the same moving holograms albeit of different values. So is the Proton, Electron, Neutrino, Sun, Moon, Galaxy, the human being, one has only to name it. The epitome of the concept of spirituality is the field or Kshetra that forms the human soul, the very opposite of the common view of 'materiality' in a matter dominated world. But the human soul is nothing else but a Moolaprakriti hologram, the very Kshetrajna or the 'knower of the field' that Sri Krishna explains to Arjuna in the Bhagavadgita. Then where is the difference between the so called matter composed of electrons and protons of  $10^{27}$  Moolaprakriti units and the spirituous soul of a human being containing the same number of those fundamental holograms? Only a heckler will fail to see the identical nature of the two states of manifestation. That is why Arjuna is told to be without the three Gunas in order to understand the true nature of phenomenon. Because the Guna or innate genetic quality of an individual, clouds his ability to 'see through' the confusing variety of manifestation, that hides the real nature of an event. Or in simple words don the robe of

## Secret Of Sankhya: Acme Of Scientific Unification.

objectivity to see the woods for the trees. Physics too suffers from the same malady for in naming the Planck's constant as an 'unit' of energy they had unwittingly collared the very holographic tornado in its nascent state. One hopes that Maharishi Kapila's unification paradigm would end the needless divide between Physics and holistic science or the materialistic science and spiritualistic religion. Its time that man realised, by uniting the two pseudo-concepts, natural law will allow him to really experience the bounties of this magnificent universe in the easiest possible manner.

3. In conclusion, he demonstrated the oneness in the material underpinnings of Reality with the spiritual supremacy of a God concept, as just two complementary aspects of a contemplative human mind. Or the concept of God and the Cosmos being inseparable in the Vedas, it was an Omnipresent, Omnipotent and Omniscient state.

The Visvarupa state in the 11<sup>th</sup>. chapter of the Bhagavadgita is a pedagogic expose of the equality of the concept of God and the Universe in symbolic terms. Pedagogic definitions are open to misinterpretation. Mere numerical identification, though precise, is again open to being labelled an absolute, which has no relevance in a relativistic world. But numerical axioms are a relational truism based on the natural proportionality of numbers that remain true eternally. As shown earlier, the first interaction can only take place between two objects and can only occur in three modes. Out of myriad possibilities, Sankhya derived one axiom that described the three Guna modes of interaction which was correct under all variations and for all times. It encompassed the law of self-similarity when two or more modes of action occurred simultaneously. Recall the earlier example of the bow. Astoundingly through that one self-similar Guna law, Sankhya theorems derived all aspects of universal manifestation and the small-tabulated example shown

507

## Secret Of Sankhya: Acme Of Scientific Unification.

above is a witness to its profound depth. Maharishi Kapila proved mathematically that one axiomatic law of Dharma operated eternally, self-organised and self-controlled, thus enshrouding it with the indelible mark of divinity. It truly described a Universe beyond humanity. It needed no human beings to understand Cosmic physics. Viewing it objectively it must be so. It is indeed an axiom.

Maharishi Kapila was only needed to tell other human beings what that exotic law was for he understood it. But why was that necessary? Could not others too do what he did? They too could have and that was the theme in the Bhagavadgita. It was just one simple message -be without the Gunas. But how could a human being be without the Gunas unless he knew what it was and that it was there in the first place. Even after 400 years of dedicated modern scientific investigation Physics had not even suspected its existence, let alone discover and use it. Then how can man? That was the theme of Maharishi Kapila's Sankhyayoga where he laid bare the meditative Siddhi process operating in the Guna mode (through Suthras 4,5 and 6) that was later elaborated by Maharishi Patanjali. Despite this caveat, man, driven by innate feelings of dissatisfaction, sought the very same goal that Maharishi Kapila did. But in another way. Man's dissatisfaction came from within him. To a fundamental query like 'who am I' to his left cerebral lobe with sequential analytical abilities, the right cerebral lobe awaited its reply. It kept on processing that reply in the holistic simultaneous mode till it was satisfied. While in the case of Maharishi Kapila, it stopped and he created Sankhyayoga, but for all of us lesser mortals, it still kept seeking an answer. On being diverted to do its essential chores, the right cerebral lobe cried a temporary halt and holistically named the Creator as the cause of 'who he was'. Changing this mindset needed a paradigm shift towards a purely intellectual objectivity, wherein all past mental conditioning had to be

508

## Secret Of Sankhya: Acme Of Scientific Unification.

jettisoned ruthlessly, even if temporarily. The meditative Siddhi process did just that and increased the chances of attaining a satisfactory answer. While the dichotomy continued, the contemplative search too continued to support the need for a separate Creator to create an Omnipresent Reality. When would it end?

The intellectual greatness of Maharishi Kapila lay in his demonstration of an extraordinary fact, through the opening Suthra. Wherever manifestation dissolved by attaining a coherent (hence restful) state, what was left was the Aikanta-Athyantha-Atho-Abhavath state or the Coherent, Eternal, Dynamic but Unmanifest state of Brahmanda, the fundamental field of cosmic space. Its perfection lay in the fact that this process applied to any fundamental field for there was only one Guna law for all such fields. Hence, the cerebral field too, if allowed to attain its fundamental state, was left in the Aikanta-Athyantha-Atho-Abhavath state. It was an axiomatic Siddhi state where the left and right cerebral halves balanced perfectly because the Gunas disappeared into its single Moolaprakriti transmigration state. It was at last without the Gunas. The concept of Creator and the Reality dissolved into each other and what was left was only an extraordinary experience of that fundamental field of Brahmanda in the Aikanta-Athyantha-Atho-Abhavath state. The remnant state of utter and deep satisfaction helped to change the mindset in time. Having demonstrated that the conceptual difference between the Creator and the permanent Reality actually merged into one another, that fundamental state could then be described objectively only as an Omnipresent, Omnipotent and Omniscient state. Or Brahmanda, the field of Cosmic space. Was there any uncertainty? None except in the human mind that lacked the knowledge to overcome it. Can we quantify the error factor that a human mind must accept? Yes, it is just one Moolaprakriti transmigration rate

509

Secret Of Sankhya: Acme Of Scientific Unification.

for 1/10 of a second. Can we sum up the gift that the intellectual colossus, Maharishi Kapila, gave to humanity? What could be greater than numerically specifying THAT extraordinary state of REALITY in unequivocal terms for mankind so that he learns that there is no such a thing as UNCERTAINTY in that state in the Universe.

Secret Of Sankhya: Acme Of Scientific Unification.

Appendix 3: The Siddhi Meditative process.

### SIDDHI

*(The ideal, scientific, non-religious, process to maximize human life energy potential)*

Sankhya theory was derived axiomatically by Maharishi Kapilla. He expounded the physics of universal phenomenon through a simple but advanced mathematical system. It forms the core of the Bhagavadgita. In it, the scientific principles from Sankhya are conveyed to us through a series of dialogues between two idealized personalities. The Bhagavadgita in turn formed the core of the Mahabharata and provided the ideal backdrop. Its complexity had the inbuilt potential to present every aspect of phenomena in a visual way. In ancient times, there was no better medium than dramatisation to spread important knowledge. The dramatised version of the Mahabharata is known the world over but Sankhya, its core, has not even been heard of by a majority of Indians.

Yoga Sutras, based on Sankhya principles, was composed by Maharishi Patanjali. He laid down a system of practices by which we could attain the ideal state of living. The Yoga Sutras emphasized that the key to it was in organizing and using human-life-energy in the correct way. The perfect but simplest method lay in attaining a relaxed and harmonious state called Siddhi in Sankhya. Based on fundamental scientific principles, it was not only an easy and definite process but it was also the quickest in achieving results. It is nature's own way.

The brilliance of Maharishi Kapilla laid threadbare the intricacies of the gravitational force in Sankhya and the equally brilliant Maharishi Patanjali used its effects to prescribe a method of maximizing our life energy

## Secret Of Sankhya: Acme Of Scientific Unification.

potential, in the shortest time. I would like to specially emphasise here, that the process of deriving that knowledge is unparalleled in our history of scientific progress, for these principles are absent in current physics. We should indeed be forever beholden to these two intellectuals, for providing this unique method of attaining excellence in our living process, by maximising our life energy potential with utmost ease, comfort and certainty. Before we can learn and practice this exotic process, it is essential to understand the few preliminary facts given below.

A summary of the Yoga Sutra led to the following three important principles.

- 1) 'Submit to the resonant field in coherent space'.
- 2) 'The seating posture provides the quickest and easiest way to Siddhi.'
- 3) 'The seating posture must be steady and comfortable'.

As we see, the emphasis is on ease and comfort in sitting, in a particular way. However, to understand its connection with the resonant state of space, we need a brief explanation of the qualities of space

### A brief explanation of the Sankhya view of space :

The characteristics of space has been accurately identified and defined numerically in Sankhya theory. Leaving its mathematical definitions aside in this write up, we can describe its observed qualities (as given below) which, can be taken as an axiomatic base. It will enable us understand how and why we should submit to its resonant state.

- a.) It is in a coherent state. Therefore it presents a unified and homogeneous state of existence.
- b.) It exists continuously. It acts as a continuum and therefore seems to exist permanently.
- c.) It is amorphous and flexible. It therefore changes and interacts dynamically.



## Secret Of Sankhya: Acme Of Scientific Unification.

d.) It is observed to be in a passive state normally. It therefore seems un-manifest and un-detectable.

When any two adjacent objects interact, it must collide, rebound and separate. This is a cycle of three phases in an interaction. Space is formed by a sea of fundamental components called 'Moolaprakriti', in Sankhya. When each of these units interact with adjacent ones, the cyclic interactions continue endlessly and follows a unique and axiomatic law. Over a period of time, the interactions organize into harmonious and balanced groups of resonant vibrations. All the phenomena we witness are just such groups in various degrees of organised states. A human being (and every other thing too) can be seen simply as a very highly organized bundle of Moolaprakritis. It cannot be anything other than a Moolaprakriti, but this bundle is called a Purusha state, to identify it as a separate unit. . Scientifically speaking, such an organized group of cyclic vibrations form a holographic state. It lays the foundation for the concept of spirituality or the amorphous state of all existence. Quantum theory in current physics has concepts similar to Sankhya but without the latter's advanced mathematical structure.

We (and all other things too) are always immersed in this resonant sea of vibrations. In other words, we are continuously in and covered by a sea of energy. Seems ideal but the rub is in the 'states' of energy. While space is in a coherent or apparently passive state, we are continuously in an active or manifest state. If we want to absorb this energy we must reverse our state and reach the same coherent or passive level. Maharishi Patanjali provided a method using, the most fundamental scientific parameter in the universe, the force of gravity. The key to achieving success in any walk of life lies in understanding what we are going to do. Briefly, we must understand a simple phenomenon called simultaneity or simultaneous

513

## Secret Of Sankhya: Acme Of Scientific Unification.

action, which forms the underlying cause of gravitation and the process of Siddhi.

The simplest way to understand simultaneous activity is to count claps from a number of people. A clap provides an easily understandable model of an interaction that creates vibrations. If ten people clap once, one after another, the counts are ten. Whereas, if all clap once exactly at the same instant, then the detectable count would be just one. The significant factor to note is that nine counts vanish. The nine hidden claps form the simultaneous state of activity. All the nine hidden claps act simultaneously with the one countable clap, as one coherent clap. Hence, simultaneous activity creates coherent states that act as a single unit. These are the states that provide the hidden potential behind any activity in our existence.

The vanishing count creates a serious imbalance within a harmonious or balanced state. Imagine ten people facing ten others opposite them and blocking their path. Suddenly, if nine from the opposite side regroup in a line behind one of their own, nine of the ten people could easily walk through to the other side, for their paths would be free. Again we see that though 20 people were there in both phases, the state of their organisation created an unbalance. Just by re-organising, nine of them were able to drift or gravitate towards the centre of the opposing group. Maharishi Patanjali prescribed a simple method of sitting comfortably to achieve the same effect. Another analogy would make that point clear. Imagine a porous pot immersed in water. If you keep shaking it all the time very little water would seep into the pot. On the other hand, if you let the pot remain absolutely still, water from all the sides would simultaneously seep into the pot and fill it in the shortest time. Recalling that we in effect are a bundle of Moolaprakritis, just like a porous pot, we must learn to sit very still indeed to absorb from the resonant sea of

514

## Secret Of Sankhya: Acme Of Scientific Unification.

energy around us. We shall see next, why the seating posture is so vital to attaining the Siddhi state.

### The reason for the critical importance of the sitting posture

The human body balances itself constantly and continuously against the stresses created by the ubiquitous gravitational force. There is not a moment in our lives when we are free from the effects of gravity but we have learnt to ignore this aspect completely. All the cells in the entire body are in a constant state of activity to attain an internally comfortable and balanced state. In fact, a significant portion of our life energy potential is not only used up in this activity but that state prevents the transfer of energy as potential, from the resonant sea of energy we are immersed in. As explained earlier, the only way to initiate the transfer lay in attaining a coherent state. That is, the state in which all the internal activities synchronised into a simultaneously active state. Our normal view and understanding of phenomena would give us the impression that it would be impossible.

We know from physics that the gravitational force acts on the centre of bodies or masses. Any object can be balanced, only if its mid position, called the centre of gravity, falls vertically in line with the point on which it is resting. In other words, as long as the centre of gravity of a body remains vertically in line with its resting point it remains in a stable state. It means that in order to maintain balance, one has only to correct that miniscule and almost imaginary position of the centre of gravity within the body. It can be shown mathematically that in the balanced state the corrective effort needed to maintain it, becomes relatively miniscule. In that state the human body acts in a coherent manner in which all the cells seem to interact simultaneously with its centre of gravity. That significantly removes the need for energy to balance the internal

515

## Secret Of Sankhya: Acme Of Scientific Unification.

stresses and our body attains a state of balance in which we feel rested and comfortable. In that coherent condition, the body's life energy potential equalizes with that of the resonant sea we are immersed in. Balancing of energy potentials is a physical law of nature and takes place by itself, when the right conditions are maintained. As we all know there is no shield to stop the gravitational potential from acting on all matter.

### The sitting posture

To attain and maintain a balanced state the torso must be kept erect in a vertical position. To maintain a relaxed state one must sit. We think we can sit straight and upright but it cannot be done unless we consciously make a correction to compensate for the curve of the spinal column. The human spinal column is arched near the small of the back. If we are to keep the torso vertical, in a relaxed state, we must sit on a sloping seat that compensates for the spinal curve. Since sitting on a flat seat needs stressful effort to keep the torso vertical, it cannot help us to attain the Siddhi state. Kneeling, sitting on ones haunches are stressful & painful postures. The ideal position is shown in the sketch below. A cloth, blanket, towel etc rolled up to the right diameter to suit each individual's physical form, gives the correct seating angle to maintain the stable, vertical posture.

Though the method of maintaining the seating angle has come from the original authors, we can follow any sitting preference, provided the need for absolute comfort in a vertical posture is not overlooked. There is scientific evidence, given at the end of this write-up that shows the window for the onset of the Siddhi state is extremely precise. The positive aspect however is certain, for under the correct conditions, the onset of the Siddhi state cannot be stopped. That is, if one sits at the correct

516

## Secret Of Sankhya: Acme Of Scientific Unification.

angle, in a bolt-upright posture and allows oneself to reach an absolutely relaxed and comfortable state, one must reach the Siddhi state. If one tends to fall asleep the loss of balance would certainly awaken the individual. In the extremely relaxed state one would even renounce the initiative to think.

When seated correctly on the edge of the rolled up cloth, your upper part of the body will be in a very balanced position. Because of the finely balanced and relaxed state you may experience a tendency to rock back and forth slightly. Its normal but you can ignore it. In that balanced and extremely relaxed state the pulsing of the femoral artery at the groin initiates the rocking motion, in step with its pulse rate. One can ignore it and allow the Siddhi state to set in.

In Siddhi one will lose all sense of the passage of time. That is the hallmark of a coherent and simultaneously interactive state. During that period and (repeat) only during that period the equalisation of the potential energy from the resonant space is completed. Since it is a mechanical process that follows the same unique natural law of the gravitational field too, the Siddhi state ends in 21 minutes. On completing a perfect Siddhi cycle you would find that 21 minutes would have passed but your own awareness may give you the feeling that it was just a couple of minutes.

Siddhi is the silent, mechanical and invincible process that enriches life energy by equalizing with potential of the resonant field of space we live in. Abundance of life energy allows one to maximize ones effort to overcome all problems in life. The full inner potential guides the genetic ensemble to reach its maximum efficiency in the way it wants to. The higher level of life-energy prevents one from becoming tired quickly and encourages the individual to seek alternatives

## Secret Of Sankhya: Acme Of Scientific Unification.

confidently. It leads to flexibility in thinking and intelligent use of nature's laws.

Though the Sankhya theory covers all these aspects with accurate mathematical values, I will only briefly touch on the scientific evidence available freely in the public domain. Medical research has established by brainwave monitoring that there are four states. Beta state, identified as the normally active one, has shown that brainwave frequencies vary between 15 and 25 cycles per second (cps). Alpha state, connected to the relaxed state of an individual, shows a range between 7 and 15. The Theta state forms the transition phase between sleep and relaxation, ranging from 3 to 7 cps. The Delta state, involving the sleep phase, shows a range below 3 cps. However, at 3.75 cycles in the Theta state, a remarkable synchrony between the left and right brain hemispheres have been recorded on individuals in deeply meditative states. The brainwave phase and frequency have been shown to merge or synchronise in perfect step. Along with it a variety of important changes in physiological parameters have also been recorded. Since those ranges and limits have exceeded medically expected levels, such phenomena have remained without any substantiation from currently understood physics principles.

It is common knowledge that satellites circle the earth in 84 minutes. A circle contains 4 phases of 90 degrees each. At each change of phase the direction too changes. When the phase or direction changes completely the simultaneous state of any activity is re-arranged into a new setup. Therefore in 21 minutes the phase changes and the Siddhi state, being primarily a process of equalizing potentials, also breaks up.

Sankhya theory has established that simultaneous activity creates the coherent state which defines the energy potential. The Earth's circumference is about 40 million meters and the transmission velocity of the gravitational

518

## Secret Of Sankhya: Acme Of Scientific Unification.

and electromagnetic field is 300 million meters per second. It gives the range of variation of the simultaneous state as 1 to 7.5 times a second. The median is half  $7.5 = 3.75$  cps. Is it a coincidence that the Earths energy potential varies exactly at the same rate as the Theta state? How did Maharishi Patanjali know that this synchrony would create the most exotic human state called Siddhi? The answer lies in Sankhya, which derives the state in which an harmonic oscillatory state is maintained perpetually if the ratio of exchange approaches a rate of 3.571 oscillations per cycle and it also proves with exquisite mathematics that all of space is always in that state.

Secret Of Sankhya: Acme Of Scientific Unification.

Fig. Seating Angle.Note:

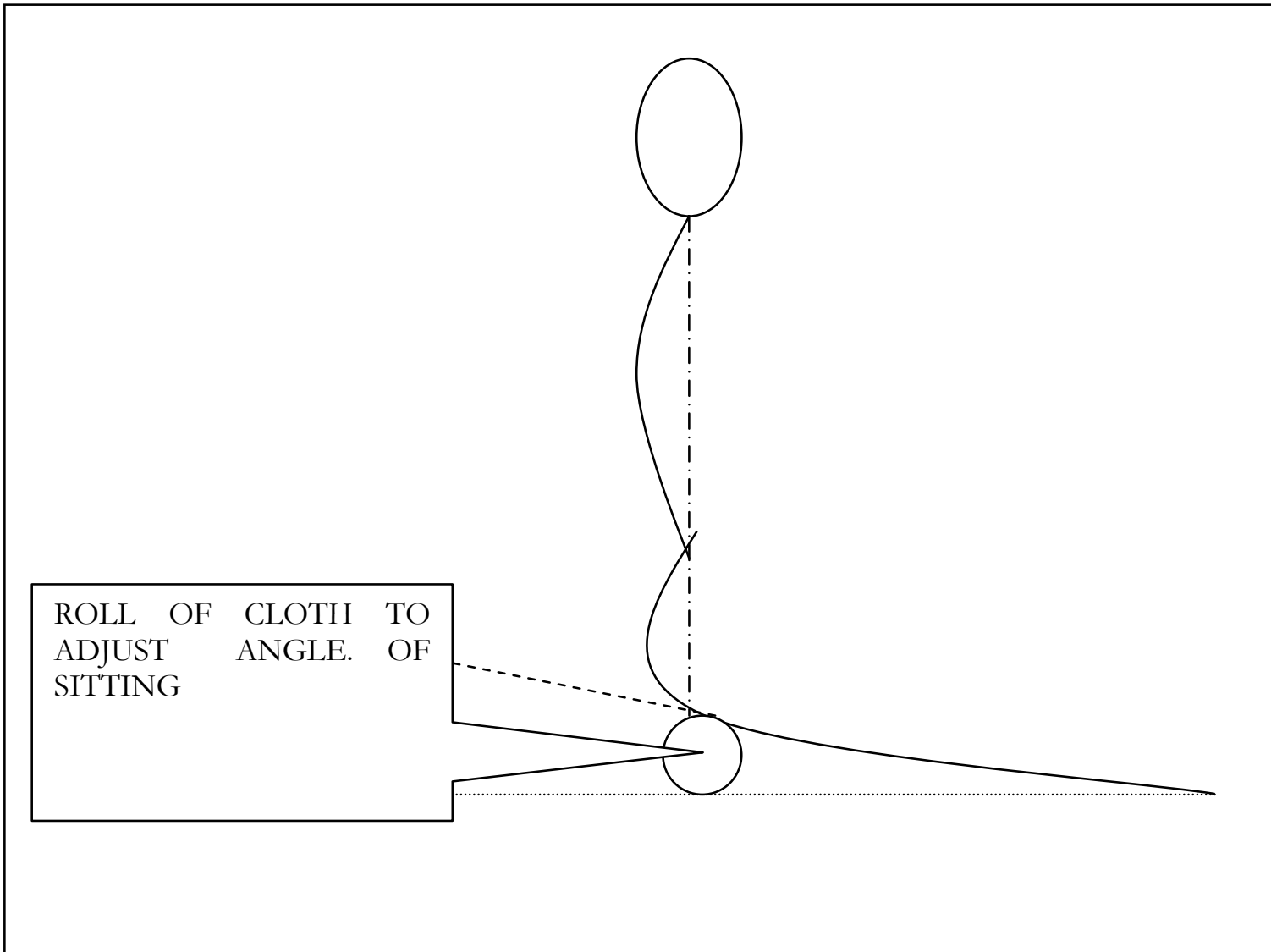

As Instructions:

Choose a quite, pleasant and clean room or area to attain the Siddhi state.



## Secret Of Sankhya: Acme Of Scientific Unification.

Roll up a thick towel or thick cloth into a tight roll of about 7 or 8 inches in diameter. Or you may adjust the roll to attain the maximum comfort. Sit on the edge of this roll, with your legs crossed or placed in any comfortable position on the floor or a stable platform.

Your spine and torso should be kept upright. By sitting on the roll you will be able to maintain an erect and vertical posture but the seat and legs will form a slight angle with the floor. The seating angle compensates for the arch in the back and yet enables one to keep the spine and torso in an upright position. If you cannot bend your leg, sit in exactly the same way but on an adequately raised step or platform so that you can drop your feet and remain in that posture in absolute comfort.

When seated correctly on the edge of the rolled up cloth, your upper part of the body will be in a very balanced position. Because of the finely balanced and relaxed state you may experience a tendency to rock back and forth slightly. Its normal but you can ignore it. Allow yourself to drift into a totally relaxed state. As the relaxation level increases you will even renounce the initiative to think.

You may not be aware when you enter the Siddhi state so it's best to let everything happen on its own. In a similar way, we cannot know when exactly we fall asleep. You cannot fall asleep in that posture for on losing your balance, you will wake up.

You will naturally come out of this state in about 20 minutes. But your awareness of the passage of time may give you the impression that only a few minutes have passed. The positive realisation that time has been lost or compressed is the hallmark of the potential equalisation process.

Secret Of Sankhya: Acme Of Scientific Unification.

## Appendix 4: Sankhya And Einstein

Ref: 'Meaning of Relativity' Indian Edition 1965. (Sixth edition revised 1956-reprint 1960)

There's a mythical story circulated by ancient intellectuals which goes like this: To the question where does the earth rest in space one ethnic replied it was on the back of a giant tortoise. It was promptly countered by another contemporary that the tortoise was too small so it had to be a giant whale and despite numerous intellectuals joining the philosophical fray no acceptable answer to end this quest was found. Sad to say but that query is still unanswered to date. The tenor of the humour one saw in these ancient answers would be no different from those views expressed by our contemporary intellectuals.

In Appendix 2, page 134 of the above referred edition, Einstein has raised a query and answered it as follows: "What innovations in the post-Newtonian development of the foundation of physics have made it possible to overcome the inertial system? First of all, it was the introduction of the field concept by, and subsequently to, the theory of electromagnetism of Faraday and Maxwell, or to be more precise, the introduction of the field as an independent, not further reducible fundamental concept". Einstein deftly refrained (on page 3) from analysing the Galilean tortoise of points forming the independent-field-continuum, and glossed over the Newtonian whale called inertial systems, to adopt the undefined Faraday-Maxwell substitute of a field.

The irony of this process is particularly evident when one realises that there is still no precise mathematical definition of what a field in physics really means today (2004), yet Einstein proceeded to fill the paucity in logical continuity by introducing the infinitesimal displacement-

523

## Secret Of Sankhya: Acme Of Scientific Unification.

field as a workable mathematical entity, without a real and physical meaning.

Here it is worth emphasising the Sankhya axiomatic logic that, intellectually and physically, it is impossible to deal with 'nothing'. Hence 'nothing or empty space' must be dealt with as a real 'some-thing' and the field as a 'substantial element' of space. Another axiom that gives the clue to deriving a perfect theory is the concept of looking at cosmic space as though it were populated with cubes, however small, for it forms the simplest mathematical expression to describe the Universe in terms of elemental components, regardless of how large the cosmos may be. Further, the moment the description of a unit of anything, say even a Universe, is categorised as one, then it demands a mathematical anzats that defines its singular status through the concept of simultaneity, (which does not exist in physics today) because the entire ensemble acts together simultaneously.

If this singularity, whether it be a Universe, Galaxy, stellar or planetary body, can be represented by any numerical quantity, then it axiomatically provides its boundary or limiting condition by the reciprocal of that value, for it forms the unit base. The entire mathematical process conceptually and actually reduces to a mere process of counting. An axiomatic approach to solving problems has an extremely precise principle as a corollary. It is the principle of self similarity that derives all its laws from within itself and is not dependant on any external inputs. Putting it succinctly, either such a theory works or it does not.

Such axiomatic logic loops back to synchronise with its starting proposition with just six equations to provide an identical, equal and exact numerical value as the correct answer to a problem. It has the extraordinary power of supplying its own proof by the six redundant equations. If the answers to these six equations are different and inexact

524

## Secret Of Sankhya: Acme Of Scientific Unification.

then it cannot be the theory and must be rejected. Einstein has himself dealt with this aspect in appendix II as the strength of equations. The outstanding achievement of Sankhya logic is that it derives an axiomatic basis for every point in space being the permanent and continuous source of maximum power by naturally functioning as a tiny blackhole-quantum, the laws of which are an exact replica of the largest Blackhole, the Universe.

Such symmetry, on its own merits, is an admirable quality that mathematicians dream of but seldom realise in reality. Notwithstanding the power of mathematics, scientific analysis must also be unequivocally bound to such rigorous human logic, that it is deemed to be of an axiomatic nature and it should only be supported by mathematical calculations to maintain precision and logical continuity.

Mathematical expressions can be seen as a concise means of transmitting knowledge, as formulations, devoid of ambiguities. Any mathematical process by itself is not based on absolute logic but forms a tool to augment logical explanations, which again depends on the skill of the investigator to find ways to use it meaningfully. Unfortunately there exists a section of intellectual opinion today that expect the un-understandable aspects of nature to be made meaningful through an iterative and mechanical application of advanced mathematical procedures. But the past history of scientific development shows it cannot replace the intuitive logic exposed by human innovative intelligence. Einsteins's theory of General Relativity is a case to point.

A considered analysis of Einstein's views on gravitational physics, is presented in this paper, as an equivalent comparison to the concepts elucidated by Maharishi Kapila in Sankhya. The question, why should one compare only Einstein's theory with Sankhya, can be answered by the fact that General and Special Relativity still remain the number 'one' in physics and cosmology.

## Secret Of Sankhya: Acme Of Scientific Unification.

Secondly the intellectual basis and content of relativity is logical and its foundation is based on an acknowledged deficiency arising out of the experimental failure (Michelson-Morley experiments) to detect and define space. Till then, however, the prevailing scientific opinion supported the view that space had real properties, similar to Sankhyan thinking. Hence any argument for an alternate theory can be confined to analysing these primary inadequacies and bridging the gap in concept & theory then becomes a complementary effort rather than an exercise in confrontation.

Sankhya principles do not violate any aspect of science. It compliments it by providing the means to decipher the hidden regimes. The current variant theories under the caption “String”, “Super-symmetry”, “GUT” & etc., are all covered in Sankhya as an integral part of its normal evolution through its self-similar and scale-invariant axiomatic mathematical logic. Hence no effort has been made to compare these newer theories explicitly and in any case the essence of these theories are not really different from the acknowledged relativistic concepts, except for the difference in its mathematical procedures and experimental conformity.

Einstein, in Appendix 2 under ‘General Remarks’ has given his sincere and deeply thought out rationale why he considered his approach to relativistic theory as the only possible way to avoid field theoretic complications leading to more complex equations. He outlines the possible variations like increasing the number of dimensions of the continuum, adding vector fields to the existing displacement tensor field and involving equations with higher orders of differentiation. But he felt neither physical nor empirical reasons existed that compelled one to take these steps. However, he made the point, that as of then, any field theory was not completely determined by the system of field equations. He raised the question that

526

## Secret Of Sankhya: Acme Of Scientific Unification.

should one admit the appearance of singularities which necessarily leads to postulating its boundary conditions. He did not think it was reasonable to include such postulates in a continuum theory, as it would be far too vague; as also the field equations would not hold for such conceptual points. Again such an inclusion, he demonstrated through a numerical example, would be an approximation at best and would strictly form an inaccurate solution in space that is free of singularities.

Einstein voiced the need for an improvement in mathematical methods, which might help such an approach. He was also critical of the need to modify a field theory into a statistical theory of probabilities through 'quantisation' as a first step, which he felt was an effort to represent a non linear process by a linear method. He further adds that one can give good reasons why reality cannot at all be represented by a continuous field. He also stated that the quantisation phenomenon implied with certainty that finite system of finite energy can be completely described by a finite set of numbers (quantum numbers).

Hence, in the very last sentence he states "This does not seem to be in accordance with a continuum theory and must lead to an attempt to find a purely algebraic theory for the description of reality. But nobody knows how to obtain the basis of such a theory."

It is uncanny that his final 'view-in-despair' seems to have been tailored exactly to reflect the logic on which Sankhya theory was based ages ago. How, each deficiency, he has voiced, is eliminated by the axiomatic logic of the Sankhya Suthras (theorems of logic) that leads to a perfectly unified theory of universal phenomenon, is presented further below.

The foregoing view on singularities was tantamount to postulating that the conceptual point was not a substantial or real element of space. Logic however

## Secret Of Sankhya: Acme Of Scientific Unification.

dictated that a 'point' must be mathematically definable as a real element of the field, if a theory was to be considered as being complete and self sufficient on its own merit. Sankhya logic overcame the Einsteinian conundrum ages ago by defining singularities as simultaneous states containing the reactions of all past interactions and likewise observable interactive states, as sequential activity involving events in the future. In a brilliant mathematical anzats involving self-similar principles, Sankhya logic showed that the boundary of a singularity was the ending point of simultaneity and the starting point of sequential activity. In the main section on Gunas (Suthras 7 to 10) the derivation of this concept is shown numerically.

A whole range of such boundary conditions could be generated as powers of  $(1/x)^n = (1+x)^n$  and the latter could be expanded as a binomial series to give a precise numerical value to its hidden internal structure. Then any unit could be meaningfully factored as  $(1+x)^n (x)^n = 1$ . It provided a spectrum of 'sequences of similarity' equivalent to the Planck's blackbody radiation spectrum. By this means not only was the boundary of a singularity defined but also made equivalent to the basic equation of motion like the Schroedinger / Dirac expressions.. At the same time it eliminated the Heisenburg principle of uncertainty for now the point or singularity contained the region of uncertainty as an expandable binomial series with unlimited choice of parameters to nail the source of uncertain time or distance, within a boundary that could be made as small as one wanted.

On page 3 of the referred volume, there is a very relevant statement that highlights the break in logic which very surprisingly is explained satisfactorily by Sankhya theorems. Einstein states "I shall not go into the details concerning those properties of the space of reference which lead to our conceiving points as elements of space, and space as a continuum. Nor shall I attempt to analyse  
528



## Secret Of Sankhya: Acme Of Scientific Unification.

further the properties of space which justify the conception of continuous series of points, or lines. If these concepts are assumed, together with their relations to the solid bodies of experience, then it is easy to say what we mean by the three dimensionality of space; ---etc” . A number of major conceptual gaps are glossed over by the foregoing statement as set out below.

‘Solid’ bodies in space are accepted as a fundamental state without further mathematical analysis. Logical completeness of any theory demands that if observable phenomenon is defined mathematically, then it must also be capable of defining through the same logic non-observable phenomenon too (like empty space) , that forms a part of what is considered to be the totality. The possibility of identifying the point, as a mathematical representation of a singularity, defining a real element or unit of a substantial field, has been overlooked, even though experiential logic clearly indicates the equivalence. The very concept of a quantum is in effect the identification of a singular and independent entity that behaves in such a way that it can be quantified by a unit integer that retains its character throughout its existence, as the activity constant in Sankhya.

The 3 dimensions of space are taken as a standard structure synonymous with a static framework of reference that lends it the factor of ‘solidity’ perceived by experience. Strict adherence to logic necessitates the demonstration through mathematical rigor the evolution of the ‘solid’ quality as a derivable aspect of observable phenomena. Such an effort would demonstrate that even ‘dimensions’ (powers) greater than 3 could still represent a non solid or non observable phase of phenomenon in real terms and not just an artefact of mathematical logic. The foregoing underscores the fact that despite all the intellectual exploration into higher “dimensional space”, real space is vectorially limited to the 3 axis in reality.

## Secret Of Sankhya: Acme Of Scientific Unification.

On the contrary, Sankhya concept is founded on real space populated with definable matter in a dynamic state whose properties can only be intellectually inferred by axiomatic logic, which is not in conflict with observation and experience. Such a process becomes vital when one realises the impossibility of deriving theoretical factors through experimental verification at the fundamental or absolute level. Sankhya logic was based on the principle of splitting space into two permanent, complementary and mathematically reciprocal factors of sequential time or activity and simultaneous time or super-positioned activity states displaying mass and density characteristics in a coherent or 'stationery' state. The implication of a such an approach was that If time or action was detected it portrayed its dynamic phenomenal status , otherwise it depicted its (reciprocal) synchronised state equivalent to its static condition.

In very simple terms it meant that the substantiality of space had no effect on our mathematical equations except its state of activity displaying sequential or simultaneous time . With this extremely simple and elementary approach the need to look at the static state through a separate mathematical anzats was eliminated and enabled the presentation of both dynamic and static phases through a single and unified formula. It simply meant that a cube described by holographic methods would be equivalent to a static expression of  $\text{Length}^3$  when in a resonant or coherent state. Hence the necessity to classify space into Galilean, inertial, Newtonian, electromagnetic field etc. were completely eliminated. In fact the mathematical derivation then exposed the various types of listed behaviour as a consequence and not apriori.

In conceptual terms it meant that observable action and non detectable activity could be treated mathematically as the reciprocal of one another; or the sequential and simultaneous aspects of time were nothing other than the

## Secret Of Sankhya: Acme Of Scientific Unification.

equivalent of the mobile and static aspect of interactions in space. Hence, even a point in space could be treated as an element of reality, which then endowed each of them with the mathematical status of a real singularity or element in the real field of space. In such a situation, the point singularity having a mathematical value lends it the quantised status and what is more, the point concept naturally leads on to a field theory with the characteristics of a continuum made up of real points.

While an objection can be raised here, that the above seems to be a repetition of the abandoned Ether concept, the Sankhya mathematics will show that it is a dynamic state so fundamentally different, as chalk from cheese. The outstanding achievement of Sankhya logic is that it derives through an axiomatic basis, the so called cubic point in space, to function as the permanent and continuous source of power by acting as a tiny 'blackhole-quantum-singularity' that absorbs all unbalanced activity and in the process has the ability to expand into the state of a gigantic cosmic spherical envelope without losing its property of scale-invariance, self similarity, self organisation and self maintenance, through one elemental variable 'time' not as a dimension but as a relational and countable state of cyclic-activity.

On page 23 Einstein makes a point that the configuration of rigid bodies have been founded upon the hypothesis that all directions in space or all configurations of Cartesian systems of co-ordinates, are physically equivalent. He refers to this equivalence as the 'principle of relativity with respect to direction' that uses the calculus of tensors to establish such equations. Then poses the query whether there is a 'relativity with reference to the state of motion of the space of reference.' While admitting there is such a principle based on Galilean transformation of co-ordinates, he points out that it fails when applied to electromagnetic phenomenon. Such a Galilean process

531

## Secret Of Sankhya: Acme Of Scientific Unification.

shows that the velocity of light varies with direction with reference to an observer whereas the equations of Maxwell-Lorentz are based on the constancy of electromagnetic translation velocity. He quotes in support, the results of the Michelson-Morley experiments that showed the velocity of light was not affected by the translation speed of the earth in space. Further, he made the point that, as there were no experiments that could be conducted on the earth to show that it is travelling at about 30kms around the sun, it confirmed the experimental findings and the correctness of the logic behind the principle of special relativity.

It is worth making an observation here, that both the problematic questions raised by him can be shown to possess contrary answers on applying Sankhya principles. The axiomatic self similar principles of Sankhya show that all phenomenon including the electromagnetic and particle ensembles are bundles of vibrations locally generated by each point-singularity or Purusha (blackhole state) in reaction to interactive stresses. The vibrations or oscillations maintain a precise and constant rate, within its own cyclic time of an axiomatic ratio . This holographic ensemble transmigrates from one Purusha state to another Purusha state like a line of people passing buckets of water from person to person without the persons themselves moving to transport the bucket. In this 'chain' analogy assume that every human is a Purusha state, the arms of the human the co-ordinate system, the bucket the earth and water the electromagnetic wave ensemble and the constant rate of change of bucket from hand to hand the velocity of earth-transfer and light-velocity, the rate of transfer of stresses in water .

The co-ordinate laws governing the transfer between bucket and human hand are governed by rigid body or mechanical considerations. One can use Cartesian, Galilean or Newtonian equations here. What is not

532

## Secret Of Sankhya: Acme Of Scientific Unification.

apparent, in the rigid-body mode of analysis, that the Sankhyan principle of simultaneity (self similar laws) is implicit as a time varying factor, but are excluded in the so called classical treatment of physics. For the rigid body is really an object of many parts acting together simultaneously. Not so the water in the bucket, for it depends on its state of flexibility and organisational form. Here one has to use equations of Maxwell, Lorentz and special relativity. The velocity of transfer of water and bucket being the same no relative velocity could be measured between the two. Michelson-Morley measured just that –a null difference between rate of transfer of earth (bucket) and light-wave (stresses in water) with reference to space or the human Purusha.

In this analogy the concept of a solid body should be replaced by synchronous and coherent ensembles of vibrations that imitates the static state and thereby projects the solidity of form, like the bucket. But another experiment could have been conducted then (the Doppler frequency shift) to show that the stresses in the water increased in the direction of movement and decreased in the opposite direction, displaying the frequency shift towards the blue in the former case and shift towards the red for the latter. (In relativity this is separated out as the characteristics of a gravitational field, implying that it was a different state.) Hence the speed of earth-motion could be derived from the Doppler frequency shift in light frequency. A new experiment, yet to be conducted, will show the bucket too (earth) will register an increase in stress in the direction of motion and its reverse, a decrease in stress at the opposite end, which could be detected as change in the angle of synchronisation or coherence of the internal stress potential.

The evidence for this factor exists even now in the distorted tidal envelope around the earth and its extraordinary nature highlighted by the maintenance of its

533

## Secret Of Sankhya: Acme Of Scientific Unification.

shape as a permanent static form, the mathematics for which does not exist in current physics. Any static form in space, where everything is in motion in relation to everything else, can only be described through formulas based in simultaneous or self-similar laws operated through a single variable. Therefore, absolute or zero movement will be represented by a perfectly spherical surface distribution of an identical-potential values in different directions from a common centre. These would confirm the Sankhya concept of the holographic coherent field of space populated by singularities in the Purusha state of a blackhole.

The conversion of Sankhya logic into the equivalent mathematical form recognised in physics, will show that the fundamental unit in space expands to the bounded universal volume in a natural and axiomatic way that encompasses the concepts of quantum mechanics, electromagnetic and thermodynamic principles in a single integrated mode that collectively displays the characteristics of a gravitational field. It shows unequivocally and unambiguously that there is only one single law, process and method that operates in diverse ways at different levels of observation.

On page 54 Einstein makes a point that as long as the principle of inertia is regarded as the cornerstone of physics then the earlier view of space as a real medium was justified. But he provided two serious criticisms of this concept. "In the first place it is contrary to the mode of thinking in science to conceive of a thing (the space-time continuum) which acts itself, but which cannot be acted upon. In order to develop this idea within the limits of modern theory of action through a medium, the properties of the space-time continuum which determines inertia must be regarded as field properties of space, analogous to the electromagnetic field. The concepts of classical mechanics afford no way of expressing this."

## Secret Of Sankhya: Acme Of Scientific Unification.

The solution to the problem posed by Einstein is provided in the main Sankhya Suthras. The definition of each component of space (using concepts allied to classical mechanics) is precisely and axiomatically enumerated as a Purusha state of a blackhole (or singularity), which has the properties of a coherent (centred) field that displays radiative (or electromagnetic) action when it's balanced state of activity is upset but returns to the coherent state (synchronous-field or inertial or static state) by absorption of all non synchronous activity. It seems to act but not react immediately and displays the typical dual-field property of a 'one-way ground state' or activity sink or absorber field.

Here the principle of field action is described in two ways namely that non synchronous or circulating field activity can be described by electromagnetic laws of Maxwell / Lorentz and special relativity whereas synchronous field activities achieve self similar coherent states that display qualities of mass or inertia and must be described by the self similar field laws of a singularity that are equivalent to Newton's gravitational laws, Einstein's General Relativity and blackhole mechanics delineated by Hawking et al, the latter three of which are true only as a boundary condition of the real point in space. The formulation of  $1/x = 1+x$  defines that boundary condition where the Schroedinger equation begins to function and the uncertainty of observable can be minimised to as small a bound as one can or want. The magic here is that a blackhole point or singularity (which represents the most dynamic state) resembles the perfect static holographic state, when expressed mathematically by a single law. One cannot but agree with Einstein's observations that there is no statistical uncertainty in nature which in the context of human thinking gives it the divine base.

Later, on page 55 he says "In the second place, classical mechanics exhibits a deficiency which directly calls for an  
535

## Secret Of Sankhya: Acme Of Scientific Unification.

extension of the principle of relativity to spaces of reference which are not in uniform motion relatively to each other.” Here he points out that even though there are two different conceptual modes of defining the cause of acceleration as being due to an inertial or gravitational mass, the values from both are always identical and equal to each other. He concludes that this equality of both types of mass is justified in reality (through experiments of Eotvos etc) and before theoretically accepting this equivalence one must show that the two different concepts of mass derivation are the same in principle. Using relativistic logic he analytically concludes that the equality of both masses can only be confirmed if the system was considered to be at rest relative to each other but the accelerative property was inherent in a gravitational field that influences and determines the metric laws of the space time continuum.

The rather extenuating mathematical logic, used to arrive at this conclusion given above is, on the contrary, made simple and precise by the Sankhya concept of a holographic base for all manifestation. This sea of singular, elemental matter comprising cubic point singularities provided the base for phenomenon. The singular element in the midst of an infinite sea of such components cannot at all have the freedom to move, transfer or translocate in any manner whatsoever in a relative way or in other words each component is always at rest relative to each other. It shows that there is no need to explicitly derive or state the principle of equivalence. Due to any initiating cause it can only interact with the adjacent components but not being able to move, it merely creates vibratory stresses as a reaction. However, the interactive stresses of the neighbouring components can and must transmigrate as vibrations or oscillations along this vast sea of unitary components. Its interactions again can only be in three modes, that is towards each other (compressive or inelastic

536



## Secret Of Sankhya: Acme Of Scientific Unification.

) or away from each other (expansive or elastic) and continuously oscillate in both the previous modes (resonant or bound states).

The components cannot move but the vibratory stresses can and at the very first level it can and must commence as an interaction between two units. Again, in such an initiating mode, Sankhya logic stated that the fundamental interactive stress must transmigrate directly in a straight line and cannot 'curve' logically. Summation of subsequent interactions produce the 'curvature' as a post interactive reaction that is related to the different rates of interactive activity between any two axis. This difference creates the non linear mode of action. As shown later, the value of  $\pi$  is the sum of all the displacements due to a standing wave resonant state at any or all rates of interactions within a boundary. At an axiomatic cyclic oscillatory rate of  $5.1 \times 10^{13}$  / cycle the 'curvature' stops (the so called string) as this value forms the maximum limit of an interactive rate in a self similar domain due to a third order damping constraint (caused by axiomatic reasons) and the interaction if continued, instead of displaying tensor / vector or curvature characteristics, flips to the opposite position or undergoes a parallel 'displacement' depicting scalar properties.

It is here that the electromagnetic mode of behaviour thus far changes over to a linear or parallel or radiant movement mode. Maxwell / Faraday laws end at  $10^{13}$  and in just one cycle rises to  $10^{26}$  to synchronise and act in a coherent mode along two axis to display mass. The stress energy tensor value of  $10^{-27}$  can be shown to be the reciprocal of the previous sequence. Here it crosses the containment boundary and radiates because the vibrations cannot superpose or compress any further on its own potential and now behaves as a 'solid or simultaneous-action' section. The notable point about this characteristic is that interactions curve inward or display

537

## Secret Of Sankhya: Acme Of Scientific Unification.

elastic properties up to the 13<sup>th</sup>. order but beyond it the radiant path is linear and outward, typical of inelastic collisions.

But the enigma in understanding this action is confounded by the logarithmic nature of the transition – that is upto  $10^{13}$  it moves predictably in time following EM laws but just at one cycle past that critical value it jumps to  $10^{26}$  counts suddenly. At this point of flipping across the boundary the fundamental cubic singularity transmits its stresses in a radial outward mode. Sankhya deals only with these stresses, as a dimensionless numerical value that indicates the interactive counts per cycle and shows how it builds up all the phenomena we observe, as a real hologram through synchronous resonance that remains as a coherent ensemble of vibrations around a passive core, at all levels of phenomena, be it a tiny nuclear particle or even a gigantic galactic ensemble.

The classical gramophone can be used as a model to understand the transition phenomenon from a flexible and linearly moving state to one of a rigid and non-moving ensemble. The orchestral sounds from numerous instruments is recorded on a rotating flexible platter through a needle as a gramophone record. Reversing the process reproduces the original sounds through a megaphone. The fineness of the tapering needle point is the key to the transfer of sound, to and from the spinning record. If one froze the room full of sounds, at any instant, to a represent a three dimensional hologram made up of 'sound-fibres', that quantum from the orchestra would occupy the entire room-volume. Feeding that bunch of 'sound-fibres' instantly into the needle point, that relatively occupies a minuscule volume of that room, would seem an impossible task. Yet the record does get imprinted for on replay the entire spectrum of sounds are heard at every instant without a break.

## Secret Of Sankhya: Acme Of Scientific Unification.

Sound is a vibration that can be only caused by changing stresses of interacting objects like molecules of air or atoms in the needle or the flexible medium in the platter. The only way for the room-full of sounds to get imprinted on the disk is by the needle point vibrating in as many ways as the sounds in the room vibrate at, within the same time period. The flexible medium of the disk must also react to the changes in stress at every instant. Therefore the needle point vibrates in numerous modes to create simultaneous rings of stress of varying amplitudes which get recorded as a reaction. Sound or voice print records have displayed this characteristic of containing complex information that have simultaneous time characteristics but location or phase variations that enable the discrimination of its inherent quality of frequency and amplitude. Max Planck too found that any type of radiation contained a spectrum or a stress record that was both frequency and amplitude or wavelength dependant.

The Sankhyan view is clearly emphasised in the Gramophone example. Vibrations do not travel but only the stresses transmigrate through a medium. Sankhya makes it into an axiom. Because any process of detection or measurement or observation is purely a reactionary response to the completion of an interactive activity. An interaction between any two objects causes a colliding stress that transmigrates as a reaction. Only a stress reaction can be detected provided the interaction is completed. Detection only confirms the existence of the stress but not what caused it in the first place. For stress can be caused only through interactions of 'something'. The success of the Sankhyan fundamental view enabled it to quantum leap right into quantum mechanics, bypassing the travails in logic both Newton and Einstein experienced. The unresolvable paradox created by the famous EPR experiment is predicted clearly in Sankhya, for the electron is only a record of a spectrum of stresses in a medium.

## Secret Of Sankhya: Acme Of Scientific Unification.

Einstein's relativistic field theory also deals with such vibrations but describes it as an infinitesimal displacement tensor field of points represented geometrically as a continuum. The logic of Riemannian geometry presents the curvature of a surface as a natural consequence of its mathematics. However, its adoption into General Relativity as the model to describe the behaviour of a surface in space, presupposes that the curvature of space is a de-facto reality. Einstein makes it clear that the 'point' in the geometry of space cannot be treated as a singularity or a real element because it would have led to arbitrary mathematical postulates in defining its boundary conditions which indeed was the 'source-location' for the infinitesimal displacement field.

Einstein's problem was real because there is no mathematical method existing now that can describe a static point evolving into a (movable) displacement or field activity, without an identifiable cause / effect or action / reaction cycle and space could not be made the source as it was a vacuum or pure emptiness. Sankhya overcame this problem by showing that the geometric point in the continuum is a real elemental singularity called a Purusha, that followed the  $1/x=1+x$  selfsimilar laws. Conceptually the Universe or a galaxy seen from the "outside" from a great distance would resemble the same point. The Purusha was the repository of all the past interactions in the fundamental state of space and in fact acted as the historical record keeper by absorbing all the unbalanced interactions as a maximised static potential with an astronomical numerical stress value, to initiate activity as a vibratory source-field. The Purusha's stresses caused by interactions with adjacent ones, created the 'infinitesimal displacement' field calculable by Einstein's relativistic theory. Whereas, Einstein could not define the point because it had to be a real element in an empty space and

540

## Secret Of Sankhya: Acme Of Scientific Unification.

therefore, he found it impossible to provide the boundary conditions, especially in a vacuum.

Another caveat was that mathematically curvature of a surface produced the effect of mass or inertial characteristics and vice versa. With Riemannian geometry, there was no need to create it by a separate mathematical ansatz. Therefore, he effectively dealt only with the movable infinitesimal displacement of points in terms of space and time following geometric rules.. Moreover, the experimental failure (of Michelson/ Morley )to verify the medium of space, necessitated the derivation of the source that became a point only because it dwindled into a zero-activity state that was mathematically described as the boundary of a boundary. However Sankhya logic showed the zero activity was a only pseudo static state that actually housed the powerhouse of the universe in each point singularity of space. One can visualise this in the form of Rubic cube being subjected to intense twisting & turning activity that would be described as a surface interaction (Einsteins stress energy tensor to Hawkings super radiant phenomenon are in this domain) but in reality the entire reaction is centred on the invisible internal cube that MUST exist if it were to function as expected.

The visualisation process can be extended further by looking at the external surface as an Einstein stress energy tensor boundary activity and the internal surface of these cubes as the Hawkings super radiant phenomenon regime. But holding all this together is the invisible central cube acting as the anchor or swivel pin, that really contributes to all the reactions, though it is invisible , both literally and figuratively. {Sankhya shows through a real count value that this centre contributes the maximum rate of power transfer =  $c^5 / G$  per cycle. It transmits it by tunnelling as a transmigration phenomenon, involving a variety of particulate states that seem to function like waves.

## Secret Of Sankhya: Acme Of Scientific Unification.

Sankhya too dealt with vibrations but with a difference that instead of an empty spatial point there existed a Purusha singularity point component which was the permanent repository of all the vibratory stresses existing due to any initiating cause in space. The question that how each Purusha accumulated all the vibratory stresses is answered by the logic that if there was no externalisation or radiation the oscillatory activity had to remain within this domain and get distributed equally in time (a sequence of interactive cycles) among all the components as a 'non moving' activity-potential. The singularity thus defined has an automatic and axiomatic boundary condition, which emerges as a necessary consequence of evaluating the repository state of all possible vibratory stresses around this Purusha point, through an axiomatic logic of self-similar behaviour of components far removed from other influences.

Hence, with this concept it can be positively stated that singularities must be included, not as a stray and arbitrary appearance but as a standard necessity everywhere in a real field of elemental components. While the details of the mathematics are given in the main Suthras, conceptually defining the Purusha singularity and its boundary was simple. The in-going (compressive = inelastic) vibratory stresses from all possible sources must reside in that (centre of mass) point (Purusha) at that instant and could be described mathematically by a cubic or third order value. Next the sum of all the infinitesimal displacements of the Einsteinian variety equated to the outgoing (expansive = elastic) and resonant (bonding) stresses around the Purusha must equal the in-going stress at every instant. If it did not equalise then the algebraic difference defined the singular state along with its boundary condition. If the difference was zero it meant that the singularity did not behave as such or that it was in a passive and balanced state.

## Secret Of Sankhya: Acme Of Scientific Unification.

This equation could not only mathematically describe a singularity but also describe space that behaved as though there were no singularities. The simultaneous in-going stresses towards a point that became its limit could be described as a third order damping stress. The  $1/x = 1+x$  could be rewritten as  $x+x^2 = 1$  the balancing point and the difference  $x-x^2 = x^3$  the 3<sup>rd</sup> order damping constraint. It behaved as a constraint because it acted against the simultaneous expansion and contraction process at the SAME time. This equation then had the power to equate dynamic field equations to static (or coherent) states of the Purusha point (or singularity) with perfect linearity in the form  $(1+x)^n =$  binomial expansion. It gave an axiomatic, mathematical and logical value directly connecting the field to it's source- the point singularity, which in fact was the problematic cause that made Einstein exclude singularities from a field theory. The activity in a continuum could be described relativistically if there was inequality between compressive and expansive stresses but if it was equal it identified the quantised point or Purusha in the static state.

Just by accounting the imbalance in the in-going and outgoing values the identity of the exposed and hidden states were identified. There were no absolutes in Sankhya; even the so-called constants were not. Its perfection lay in the fact that the source of all power was local for each Purusha point of singularity, (in coherent space) was the repository of all the interactions in the cosmos from eternal times and therefore provided the maximum static potential at every point or singularity perpetually. The major inability of Einstein to accept singularities as a mathematical reality in a field theory was overcome, through a profound and fundamental conceptual change by recognising the real existence of the substratum of space in Sankhya. Now, the question could be asked “ is this concept acceptable in the experimental

543

## Secret Of Sankhya: Acme Of Scientific Unification.

domain of physics ”? The answer would be a positive yes because the outcome of the long series of the well known Michelson-Morley experiments confirmed that the earth-matter did not move relative to space. Further the Doppler effect of frequency shifts relating to motion, confirmed the Sankhya principle that expansive-compressive stresses only moved across the Purusha. The frequency shift towards the blue end of the spectrum related to compressive stresses while the red-shift was associated with the expansive stress transmigration process.

The existence of coherent (static) Purusha state also has confirmation in the highly accurate results of the Hughes – Drever experiments to detect inertial-mass anisotropy by detecting tiny frequency shifts in the atomic and nuclear resonance lines. It is shown in the main Suthras through exquisite mathematical logic that all manifestation, whether it be a ray of light or even the largest object – a galaxy , are only the variations in the coherent state of stresses residing in each Purusha or a ‘conglomeration of Purusha – singularities’ acting as a single, coherent or synchronised unit but on a different periodic scale.

The next question was that there existed an inherent incompatibility between the continuum theory and quantised presentation, which led to the ‘uncertainty concept’ of statistical probability in defining phenomenon. The question was that ' could the quanta also be broken down to such a level as that of the infinitesimal displacement field to achieve an accuracy similar to a continuum theory'? Can one replace statistical probability with interactive precision? Can one show that acceleration and mass are reciprocal states? If the displacement in space, time and rate of interactions between the ‘points’ or singularities could be represented by a set of numerical series that had the property of linearity and proportionality right down to the infinitesimal state then the combination of these three could enable the description of phenomenal

544



## Secret Of Sankhya: Acme Of Scientific Unification.

activity in the nature of a continuum with its accompanying characteristics of certainty. That is these series had to be self-similar and scale-invariant down to 'zero' displacement in space, eternal in time, perpetually resonant and the synchronisation of these three provided its own boundary naturally. Then every real point in space, however close in distance or time could be described by a linear and proportionate numerical ratio as expected in a field-continuum. Sankhya has identified these three axiomatic ratios as series. The very first Suthra in Sankhya lays down a proposition that states that the three interactive modes of stress, confirmed by experience, could not have existed but for the presence of the following 4 qualities of space:

- a) synchronous-coherence,
- b) eternal existence,
- c) perpetual dynamism and
- d) unmanifest state.

Again in keeping with the axiomatic requirements that there are no absolutes, all the (above) 4 are ratios of simultaneous and sequential activities.

## Secret Of Sankhya: Acme Of Scientific Unification.

### Appendix 5: Age Of The Vedas.

The rationale and proof of Vedic civilisation having existed 32000 years ago is given below. The Atharvaveda book 19, chapter 7, verses 1 to 5, and chapter 8, verse 1 under Nakshatradevatyam identifies 28 Nakshatras as the number of divisions in the stellar horizon. The Sanskrit term Nakshatra ( Na = 'not' Aksha = 'terrestrial latitude' Atra = 'in this case' meaning not a terrestrial latitude in this case) is a label to identify a numerical angular position or celestial latitude or longitude. It eliminates the need to specify an arbitrary angular limit like 360 degrees in a circle. The number 28 came about from Sankhya theory where Prakriti binds by 7 divisions in each direction and the four quarters gave 28 divisions in a plane giving 12.857 degrees per section in modern notation. The 7 comes from the integer mathematics used in Sankhya. The basic volume is proportional to the first, fundamental or elemental unit  $\text{radius}^3 = 1^3$  and the next incremental radius of  $2^3 = 8$  units. When the volume increases by doubling the radius, it grows from 1 to 8, or 7 volumes are added. Since the basic volume cannot be detected, because the process of detection is relative (or by comparison), only 7 volumes can be measured with reference to the first volume.  $8-1=7$ . the logic is based on the concept that a truly elemental unit cannot be fractionalised because if it can be, then it is no more an elemental unit. this is the basic reason for the spectral range of seven segments in any field.

The Sankhya system developed the integer number theory on a logical need based principle thereby eliminating arbitrary systems, like 360 degree division of a circle etc. In today's almanacs only 27 Nakshatras are mentioned. There is a very logical and accurate reason for this change that justifies the theory that Vedic civilisation existed 32000 years back and it is given below. The earth spins on its own axis in 24 hours or  $1/365.25$  of its annual

546

## Secret Of Sankhya: Acme Of Scientific Unification.

orbit around the sun. This sets the actual time of a daily revolution to less than 24 hours of clock time, if the starting point of each daily revolution is referred to a location in the sky; that is  $(24 \times 3600)/365.25 = 236.55$  sec or 3 min and 56.55 sec less than 24 hours. It means that if we use a particular stellar constellation or star at the zenith or the horizon, identifying the starting point for the daily revolution of the earth, one would see this mark arrive 3 min and 56.55 sec earlier every day and will again coincide with the same stellar location and clock time only after 365.25 days or a year. It is the natural shift in timing of an object that is both spinning and orbiting in space. The time of 23 hrs 56 min 3.45 sec is called sidereal time. Hence we can locate the star accurately at any future time by applying the sidereal time from a known date within an annual cycle. Similarly if the location of this star is recorded at a particular time, it is possible to work out the location of the observer and the date of such observation, all within the cycle of one year. This example has been quoted to show that location and date of events can be ascertained with the required degree of accuracy based on the sidereal shift in stellar positions.

Added to the sidereal shift that moves along the solar ecliptic, there is another movement due to the shift in the angle of earth's axis to the ecliptic that creates a relative change in the angle of inclination of the ecliptic. This movement is called precession of the equinox and is treated in current physics as a problem connected with spinning bodies like a gyroscope and in relativistic physics it is due to the curvature of the field. But Sankhya proves that all phenomenon is due to the synchronisation of vibrations or it is of a holographic nature and treats space like any other matter field comprising gas or fluid etc. that causes delay by superpositioning of vibrations and therefore a shift in the static or synchronised state and both these shifts are combined and defined as *Ayanamsa*

547

## Secret Of Sankhya: Acme Of Scientific Unification.

(*Ayan* = motion or movement and *Amsba* degree or division- in Sanskrit explained below). The fundamental reason that precession exists is that the oscillating or vibrating parameters along the two axis in the plane of motion is not synchronous or the synchronous nodes along the two axis have marginally different rates of oscillations. Two sets of axial vibrations can be in resonance or have a standing wave relationship if the two axis (say x and y ) have a ratio of one to two. That is the tangent of an angle of 26.565 is exactly  $\frac{1}{2}$  and at this value the resonant state at the 2<sup>nd</sup> harmonic is maintained. If it exceeds this ratio or the angle becomes smaller the resonance can only occur at a harmonic level higher than 2 which cannot be sustained. A spinning object that does not move can maintain both axis at identical synchronous rates and therefore present a perfect spherical surface of rotation but the movement in a particular direction sets up differences in time, direction or rates which causes non synchrony and therefore an unbalanced state with a non spherical surface of rotation. The angle 26.565 deg. or the tangent ratio  $\frac{1}{2}$  is an exceedingly critical parameter in space because all the vector relationships follow a law of self similarity and scale invariance. That is every connected parameter can be described in terms of a factor x raised to some integer power and x forms an infinite nested series. The shantimantra "*Purnamida Purnamadam* "etc: when decoded correctly, gives the numerical value of x , with extraordinary characteristics. It is explained fully in the "*Guna*" Suthras in Sankhya. At 26.565 deg. the resonant oscillatory rate is 296575967 which is almost identical to the velocity of light at a meter wavelength. Since the components of the substratum are also oscillating at the same rate an equilibrium condition becomes established in the field along this angle. Hence any solid spinning orbiting object experiences a resonential relationship with the vibratory conditions along its periphery and if such

## Secret Of Sankhya: Acme Of Scientific Unification.

conditions remain stable or the differential parameters maintain the same rate, then the object maintains this relationship or it becomes strapped or locked to this angle of transfer of vibrations. One must remember that Sankhya emphasises that the solidity of objects is created by the superpositioning of vibrations on the elemental component of space and only formations as vibrating ensembles travel. Hence the locked state does not lose its phase relationship easily and unless the relative rate difference exceeds the self-similar ratio, no change takes place. This is the gyroscopic effect.

The earth's equator spins at a mean surface velocity of approximately 462 m/s and the earth itself moves around the sun at an algebraic mean speed of approx. 29845.4 m/s. But the earth's axis is tilted by 23.5 deg. to the plane of revolution around the sun, called the ecliptic. As a result of this tilt, the earth's maximum spin velocity vector at the equator works out to :  $462 \times .91706 (\cos 23.5) = 423.52$  m/s. The drift of the starting point of the ecliptic is at the rate of  $423.52 / 29845.4 = 1 / 70.47$  of a cycle and the drift due to the sidereal effect is  $1/365.25$  thereby giving a total drift of  $1 / (70.47 \times 365.25) = 1/ 25739$  of a cycle. It means that an identical ecliptic coincidence of the sun and earth at a particular position will be repeated only after 25739 cycles or years in this case. This calculation has been shown in a simplified form to make it understandable but a very accurate calculation supported by many years of practical observation gives a drift rate of 50.35 seconds of arc per solar year and is only used in Vedic astrological calculations as a normal course . The precession of the equinox calculated by applying modern principles of celestial mechanics is 26000 years or (49.85 sec of arc per year.). But extremely accurate calculations give varying precessional rates at different periods and relative positions, but the 25739 rate is an average of over 30000 years. (See precess.mcd)

## Secret Of Sankhya: Acme Of Scientific Unification.

The Vedic scholars, following the Sankhya principle of self-similarity that governed the dynamic state of the Substratum, took the ecliptic coincidence as a clock time benchmark that can at least be relied on in a cycle of approximately 25739 years. This drift or *Ayanamsa* was used by astronomers and astrologers to fix the moving zodiac (ecliptic) so that accurate comparisons of events could be made in a locality where everything is moving relative to everything else. If the number of *Ayanamsa* cycles are known between events in multiple units of 25739 years, then it could be compared meaningfully.

[As an illustration of the accuracy of Vedic calculations, using the same fixed zodiac or ecliptic, one can calculate the return of the moon to the same or identical position once in 40 years. This is mentioned in the Atharva Veda book 20, chapter 34, verse 11. ]

The Vedic scholars have identified the equinoctial position in a particular period as beginning in the stellar position of the constellation Punarvasu. The term Punar means "the return or repeat" and Vasu is a "ray of light or a sighting point" and the whole word has the meaning of the starting point or point of coincidence indicating 0 deg. latitude & longitude on the orbital ecliptic. There is another proof of this position being the starting point today. Abhijit, one of the 28 Nakshatras, is situated exactly 180 degrees in opposition to Punarvasu, in the constellation now called Vega north of the equator, and was identified as a 12.857 degree sector in the sky during the period when the Atharvaveda was developed. Due to the 23.5 degree tilt of the earth's axis, any celestial body would tend to swing north and south annually just as the sun does seasonally. The total swing being 47 degrees, sectors that are far north or south would seem to disappear or the angular displacement would decrease during these excursions. In astrology such a division of sectors are called unequal houses and when calculating

550

## Secret Of Sankhya: Acme Of Scientific Unification.

positions far north or south of the equator, the same zodiacal sign would occupy two sectors or houses thereby eliminating a house completely. Abhijit, being far north, the angular displacement of the 12.857 deg. sector seems to become virtually zero during the southerly excursion once in 25739 years. Because of this phenomenon, currently Abhijit as an identifiable sector has virtually disappeared and is not included in the post glacial scenario as a Nakshatra. The period of such disappearance can last up to 6000 years depending on the declination. While the Vedic scholars divided the celestial ecliptic into 28 divisions based on Sankhya Thaamasic principles explained earlier, they gave each sector a name only to identify the angular position starting from Punarvasu as the starting point or number One sector. Since Abhijit cannot be identified, astrologers have reconciled their calculations with 27 sectors of 13.33 degrees each instead of the 12.857 unit. The names of these sectors are associated with constellation names to enable identification and the locational precision is improved by dividing the Nakshatra position by 4 sections and each of these sections into 9 divisions with a provision to improve accuracy by a further two sets of ninth divisions equalling approx. 15 sec of arc.

The Atharvaveda has given two identifiable points ; namely the starting point in Punarvasu as an indicator of Vedic history and the progress of the Nakshatra called Kritika (in Pleiades constellation) to the starting point, under the heading of Nakshatradevatyam in the 19th book, (chapter 7), the penultimate volume.

Some elementary calculations gives the number of years from the current position. Calculations show that the current starting position or the 0 degree position on the ecliptic to date is in the Nakshatra Aswini or Aries constellation between 0 and 13 degrees. As a rough guide the total ayanamsa period of 25739 years divided by 28 yields 919 years per Nakshatra passage. Taking the

## Secret Of Sankhya: Acme Of Scientific Unification.

maximum number of Nakshatras traversed between Aswini and Punarvasu as 7 then the time elapsed is  $7 \times 919 = 6500$  and if the difference between Punarvasu and Kritika is taken as 5 then  $5 \times 919 = 4595$  years. If it is surmised that the depth of Sankhya & Vedic knowledge was produced about 6500 years back, then physical evidence (archaeological) corroborating such advancement would have been available as it is in the post glacial period and could not have been destroyed. The best evidence so far indicates that the civilisation around 6000 years ago left behind shards of pottery and burial mounds (around 4000 BC) and artefacts dating 2500 BC. Analysing the ecliptic drift again, the ecliptic-equinox in the current period is in Nakshatra Aswini in constellation Aries; approximately 1838 years ago it would have been in the Nakshatra Kritika in the Pleiades constellation. Approximately 6433 years ago the equinox would have been in the Nakshatra Punarvasu in the constellation Gemini. As Punarvasu is the starting point, the development of Vedic science to the level depicted in Sankhya could not have been possible in 6500 years for one thing and the historical and geological evidence of global flooding due to a glacial melt about 10000 years ago strongly suggests that the current civilisation has virtually begin from scratch. The inundation theory has been corroborated theoretically by various investigators including Lokmanya Tilak and the plausible cause explained in his book " The Arctic Home in the Vedas". He has shown logically that the Vedic civilisation thrived in the Polar regions about 20000 years ago.

If the Punarvasu position is pursued back in time by another full cycle of 25739 years it takes the clock back by about 32165 years from the current period. If the view is taken that this coincidence on the ecliptic is the second time around then the picture is very different. Instead of 7 the sectors increase, by adding 28 to 7 gives a total of 35

552



## Secret Of Sankhya: Acme Of Scientific Unification.

sectors; which equals  $35 \times 919 = 32165$  years and reducing the current 1996 years since BC leaves the time elapsed as 30169 or 30,000 years BC.

The flooding event 10000 years back puts the ayanamsa source in the Nakshatra Magha in the constellation Leonis and there is evidence that this ecliptic coincidence has been of some significance as it is mentioned in the Atharva Veda in connection with the beginning of a serious calamity extending over a long period. A serious effort at objectively decoding (translating) the Atharva and Rig Vedas, in particular, will yield a fund of information on the history of our planet in Vedic times besides elucidating the principles of unification of all sciences. The mathematics used here has been deliberately kept at an elementary level so that the principle is understood easily. Since the translation of Sankhya Suthras have yielded exceptional information on cosmology and physics that is not yet known to current science, there is no doubt whatsoever of Lokmanya Tilak's contention that the Vedic civilisation must belong to the preglacial era. The reference in the Atharvan augments Lokmanya's findings. Besides, Maharishi Kapila's axiomatic approach has provided solutions of exceptional accuracy in describing phenomenon in an unified way, by a process of merely counting interactions. The main text provides detailed explanation of Sankhya principles.

[The following news item was received by e-mail from a colleague in the USA on 5<sup>th</sup>. Sep 2001. that may provide conformation to the above hypothesis.

Amazing Arctic artefacts discovered.  
Tools indicate hunters lived in the north 40,000 years ago.

[Image: Tusk]  
A mammoth tusk with grooves carved by a sharp  
553

Secret Of Sankhya: Acme Of Scientific Unification.

stone is shown in this undated photo. The tusk was among the artefacts researchers discovered close to the Arctic Circle.

ASSOCIATED PRESS

Sept. 5 - Primitive stone tools and other artefacts discovered close to the Arctic Circle in the desolate far north of European Russia indicate that a band of hunters set up camp there almost 40,000 years ago - far earlier than previously thought, researchers report.]

There is an additional reference from research in Oceanography. See Appendix 4A.

Notes: The stellar divisions based on 28 Nakshatras- the angular width = 12.857

(With 27 the angular divisions are 13.333 deg.)

No. NAME Degrees Constellation.

1	Aswini	0 -- 12.86	Arietus	3
2	Bharani	12.86 -- 25.71	Arietus	Mus3
3	Kritika	25.71 -- 38.57	Tauri	Aloyoni 6
4	Rohini	38.57 -- 51.43	Tauri	Aldebaren 5
5	Mrigasirisa	51.43 -- 64.29	Orionis	3
6	Ardra	64.29 -- 77.14	Orionis	1
7	Punarvasu	77.14 -- 90	Gemini	Pollux 5 Zero
			reference	
8	Pusya	90 -- 102.86	Cancri	3
9	Aslesha	102.86 -- 115.71	Hydrea	6
10	Magha	115.71 -- 128.57	Leonis	Regular 5

Secret Of Sankhya: Acme Of Scientific Unification.

- 11 P.Palguni 128.57 -- 141.43 Leonis 4
- 12 U.Palguni. 141.43 -- 154.26 Leonis 4
- 13 Hasta 154.26 -- 167.14 Corvi 5
- 14 Chitra 167.14 -- 180 Virginis Spica 1
- 15 Svati 180 -- 192.86 Boothis Arcturis 1
- 16 Visaka 192.86 -- 205.71 Libra 3
- 17 Anuradha 205.71 -- 218.57 Scorpionis 3
- 18 Jestha 218.57 -- 231.43 Antares 3
- 19 Mula 231.43 -- 244..26 Scorpionis 6
- 20 P.Ashada 241.26 -- 257.14 Sagittaris 4
- 21 U.Ashada 257.14 -- 270 Sagittaris 4
- 22 Abhijit 270 -- 282.86 Vega 180 deg.  
(Abhijit is not used in current calculations.)
- 23 Sravan 282.86 -- 295.71 Aquilate 3
- 24 Dhanishta 295.71 -- 308.57 Delphini 4
- 25 Satabisha 308.57 -- 321.43 Aquari 100
- 26 P.B.Pada 321.43 -- 334.26 Pegasi 4
- 27 U.B.Pada 334.26 -- 347.14 Peg. Andromeda 4
- 28 Revati 347.14 -- 360. Picium 3

References: atharva veda samhita w.d.whitney.

Av book 19, hymn 7, v. 2 magha ayanamsa page 906,907,908,909 , book 6 . Hymn 110, page 360, book 2, notes 8.1, page 48, book 14, hymn 1, v.13 page 742,.

Atharvaveda by Devichand M.A.

Bk. 19, hymn 7, verse 2, ayanam magha . Page 730 /731. V 1 to 5. Nashatra identity.

"The Arctic Home in the Vedas" by Lokamanya Tilak.

Secret Of Sankhya: Acme Of Scientific Unification.

Appendix 5A: Age Of The Vedas.

## **Rapid Rise of Sea Level 19,000 Years Ago and Its Global Implications**

**Peter U. Clark,<sup>1\*</sup> A. Marshall McCabe,<sup>3</sup> Alan C. Mix,<sup>2</sup>  
Andrew J. Weaver<sup>4</sup>**

Evidence from the Irish Sea basin supports the existence of an abrupt rise in sea level (meltwater pulse) at 19,000 years before the present (B.P.). Climate records indicate a large reduction in the strength of North Atlantic Deep Water formation and attendant cooling of the North Atlantic at this time, indicating a source of the meltwater pulse from one or more Northern Hemisphere ice sheets. Warming of the tropical Atlantic and Pacific oceans and the Southern Hemisphere also began at 19,000 years B.P. These responses identify mechanisms responsible for the propagation of deglacial climate signals to the Southern Hemisphere and tropics while maintaining a cold climate in the Northern Hemisphere. <sup>1</sup> Department of Geosciences, Oregon State University, Corvallis, OR 97331, USA. <sup>2</sup> College of Oceanic and Atmospheric Sciences, Oregon State University, Corvallis, OR 97331, USA. <sup>3</sup> School of Environmental Studies, University of Ulster, Coleraine, Northern Ireland BT52 1SA, UK. <sup>4</sup> School of Earth and Ocean Sciences, University of Victoria, P.O. Box 3055, Victoria, British Columbia V8W 3P6, Canada. The information in the report conforms to a period in Magha as highlighted in the Atharvaveda Bk. 19, hymn 7, verse 2, ayanam magha . Page 730 /731. V 1.

## Appendix 6: Sanskrit Language.

Any language is basically a code. Both spoken and written languages are symbolic representation of a type of logic used for communication. A monotonous sound is clipped into short pulses by the introduction of a short period of silence and these are combined into sets that are given a meaning by the user. Any cyclic vibration has a typical characteristic of reversal of action, like up and down, forward and backward or left and right and this variation can be described as creation and destruction or acceleration and deceleration or sinusoidal oscillation. If the opposing effects are equal they cancel out or the nett algebraic effect is zero which does not contribute to detectable or measurable signal. The period the pulse is on can be considered a 'mark' and the silence a 'space' and a combination of mark and space makes a cycle. Numerous possibilities can be had with different combinations of mark space ratios and therefore many forms of codes can then become languages.

Verbal languages are composed of a complex form of such codes. Similarly script can be formed by dots and or dashes against a different coloured background and numerous complex combinations provide various language scripts. A white sheet of paper forms a monotonous background but a dot in a contrasting and detectable colour forms an elementary written code. The structuring of such codes is based on principles of organising limitations or constraints. The human speech mechanism has a set of built in organs that allow him to vocalise but at the same time his lungs, vocal cords, tongue, mouth, teeth, lips and nose act as constraints to limit his ability to control sounds. Formulating all these limitations in a theoretical way allows him to maximise the range and depth of his language coding system which Sanskrit is.

## Secret Of Sankhya: Acme Of Scientific Unification.

"Sanskrit" means a refined code. "Sama" means equalised and "krit" means cut, clipped, divided, pulsed or in other words a code. The language was developed scientifically and logically as the only possible code human beings could create naturally with the equipment they had, the human body. The lung along with the vocal cords formed a sound producing device. The diaphragm, separating the lung from the stomach, could be expanded or contracted thereby enabling the production of sound, through the vocal chords. It could be extended by an additional time duration called the second time constant. The tongue, teeth and lips clipped the sound to produce the consonants of the alphabet.

The code was systematised in the following manner. Clipping the sound at the back of the palate with the root of the tongue produced a silent or hard consonant like "ka". If it was vocalised at the same time it became "ga". Both "kha" and "gha" sounds could be formed by aspirating at the same time to produce the second time constant. If contact of the tongue was softened it became a nasalised "nga" thus forming a set 5 different sounds with the same position of the tongue. It had a direct correlation to the Triguna classification of interactive states in Sankhya as Thaama Raja and Sathwa with interface states Linga & Bhava and Abhiman & Ahankar.

Further, by placing the middle of the tongue against the roof of the mid-palate, another set of 5 sounds like "cha", "chha", "ja", "jha", "nja" were created. The alveolar position produced "tta", "ttha", "dda", "ddha", "nna" and the dental position gave "tha", "thha", "dha", "dhha", "na". Next, using the lips the labial sounds of "pa", "pha", "ba", "bha", "ma" were produced. In all 5 sets of consonants with 5 characteristics in each set were created to cover the alphabetic spectrum of sounds. A third dimension was added in the form of short and long duration vowels.

## Secret Of Sankhya: Acme Of Scientific Unification.

Based on the fundamental Sankhya theory that the human ability to discriminate a change became the first detectable code which was called “matra” or a beat or period. Every code had a numerical or sequential value Now using the information we have derived so far we can set up a grid of the refined code called Sanskrit. The table of alphabetical codes & symbols are given below:

T/C =Tone/Class	Gut = Gutteral	Pal= Palatal
Alv = Alveolar	Den = Dental	Lab = Labial
SH=Silent-hard	SA=Silent-aspirated	VH=Voiced-hard
VA=Voiceaspirated	SV=Semi Vowel	Sib= Sibilant

Consonants.

T/C	Gut	Pal	Alv	Den	Lab
SH	Ka 1	Cha 6	t'Ta 1	Tha 6	Pa 1
SA	Kha 2	Chha 7	t'Tha 2	Thha 7	Pha 2
VH	Ga 3	Ja 8	d'Da 3	Dha 8	Ba 3
VA	Gha 4	Jha 9	d'Dha 4	Dhha 9	Bha 4
Nasal	n'Ga 5	n'Ja 5	n'Na 5	Na 5	Ma 5
SV	Ya 1	Ra 2	La 3	Va 4	
Sib	Ha 8	Y'sh 7	Sha 6	Sa 5	
Ending	Ksha 0				im 5

Vowels

Short	a	i	u	ir	ai	O
Long	aa	ee	oo	irl	aai	Ouw

The alphabetical code had a natural sequential numerical value and these have been marked against each sound. Numbers of any value can be represented by an alphabetical string of letters to any number of decimal

559

## Secret Of Sankhya: Acme Of Scientific Unification.

places and can be easily remembered as a picturesque phrase. Hence mathematical theorems can not only be represented as memorable phrases at the obvious level but the letters in a phrase can represent numerical values of worked out solutions. Today animated graphic techniques make it easy to communicate the most complex ideas. In Vedic times too, the same principle was used to produce a dynamic imagery through a precisely formulated oral system. Scripting was ignored as a communicating tool as meditative processes were immensely superior in absorbing field characteristics through sound control. The verses contained six types of controls as rhyme rhythm, tone, inflection, emphasis and onomatopoeic meaning. The Prathisakhya, an explanatory appendix, clarified rule changes from the normally used procedure. Ancient Sanskrit had no grammatical restrictions, for poetical compositions had to be flexible enough to convey complex ideas whereas prose, though comprehensive, failed due to its 'inability to memorise' long alphabetic sequences. Applying these factors to each set of verse 'simultaneously' through the learnt 'meditative Siddhi technique' created a real experience in the mind. The Dharma Mega Samadhi state helped to understand the meaning, as a realistic, picturesque 'mental experience', the author tried to convey

As an example the very first Sloka from of the Rigveda is decoded and interpreted as explained below.

The Sanskrit phrase with its equivalent meaning is:

*Agnimile purohitam yajnasya devamritvajam hotaram ratnadhatam.*

*Agnimile* Through expansion (by heat )  
*Purohitam* Theorising (by Pundits )  
*Yajnasya* Triggering (Sacrifice triggers nature to act)  
*Devamritvajam* Substratum of space(essence of nature)  
*Hotaram* Extraction of



Secret Of Sankhya: Acme Of Scientific Unification.

*Ratnadhatam* Free energy ( gift of the highest order )

"By triggering the expansive qualities of the fundamental substratum abundant free energy can be obtained".

The number value decoded from the original Sanskrit code is '35312861871845648862226955' It represents the numerical value of the volumetric rate of light radiated in cubic yards per unit time of one Vedic second.

Agni	mi	le	pu	ro	hi	th'm	ya	jna	as	ya
3	5	3	1	2	8	6	1	8	7	1
de	va	mri	th	va	j'm	ho	tha	ram		
8	4	5	6	4	8	8	6	2		
ra	tna	dha	th	ma	'm.					
2	2	6	9	5	5					

In Sankhya the Triguna theory of simultaneous and self similar interactions derives the standard oscillatory cycle of components in space through axiomatic theorems and equals  $2.965759669e+8$  interactions per cycle,. It is approximately equal to the frequency of modern velocity of light at a wavelength of a meter in 1.010845 seconds, which is due the earth's distance from the Sun. The solar gravity field flux density varies as the log of distance. The Meter to yard conversion factor of 1.30795 for cubic space and a time correction of  $2.99792458e+8/1.486e+11$  shown below which is an indicator of their scientific knowledge. It yields the value of  $3.5312861 \times 10^{25}$  cubic yards per second exact to the 7<sup>th</sup> decimal place of the value from the Rigvedic theorem. Statistically this equivalence cannot be an accident. An important factor is that time correction for Galactic and Earth velocities were included which means the Vedic forefathers knew of the Doppler shift in frequency due to relative movement. This proves that relativity theory is a superfluous corollary in nature. Similarly, the precessional deviation in the orbit of

561

## Secret Of Sankhya: Acme Of Scientific Unification.

Mercury can be derived precisely by the Sankhya concept of a holographic field. The spin of any conglomerate object is not a movement but a delay in 're-writing' its holographic form, which gives the illusion of a rotary movement. Just as, if the sync pulse is delayed on a TV screen, the picture will seem to move across it.

Modern Sanskrit was the result of a post glacial renaissance by the survivors of the floods. The ancient oral communication system used in the brahmanical tradition of scholarship apparently survived intact a period of perhaps a few generations. For the resurrected Vedic compositions still reflect the enigmatic original concepts, despite efforts at projecting a rational meaning to phrases that were beyond the grasp of post glacial interpretation. The interminable forays into extracting the real meaning from Vedic verses by both foreign and native savants, left behind a trail of confused verbiage, compounded and coloured by a well intentioned obeisance to anthropomorphic concepts. The hidden origin of ultra-sublime concepts, that occasionally got through the Vedic phraseology, doubly emphasised its apparent divine origin for these aphorisms, to a community which had somehow survived the awesome glacial melt that prolonged the collateral damage over centuries.

Appendix 7: Lexicon Of Sanskrit  
Terminology.

aagamat, rationale, method, approach,  
aabhyanthar, inner, internal, interior.  
aapthavach, axiom, logical, theorem, principles  
aapthi, proved, trusted, reliable,  
aasthi, real world , belief in god ,  
aathmaka, related to core state, nuclear, self centred,  
aathishayaya, abundant, maxima,limit  
aathyantha, perpetual, excessive, endless, omnipresent  
abhaavaath, quiescent, unmanifest, undetectable,  
destructive  
abhibhava, predominant, plentiful, contemptuous,  
abhighaatha, interaction, collision, impetus, obstruction  
abhihar, absorb, usurp, robbing, attack,  
abhimana, self potential, self-measure,  
self dimension, self-awareness  
abhyasa, practising, study, repetition, improvement  
achethanam, static, inanimate, lifeless, non-awareness  
adha, instant, now, moment, today  
adharma, un-principled, illogical-action, irreligious,  
adhastad, lower , below , beneath,  
adhigam, obtain, accomplish, understand, to arrive  
adhithana, source-place, primary state, supervisory ,role  
adhivasitham, superposition, occupation nos,  
residence, multiple abode  
adhya, first, pre-eminent, primary, leading  
adhyavasaya, constraint, stress,  
perseverance, determined, insistant  
adhyayanam, research, study, analysis , improvement in  
adi, original, first, principle, commencement  
adyah, first, primary, preeminent, -  
agamat, deduce, conclude, science, vedas  
agni, accelarate, expand, heat, ag=move=3

## Secret Of Sankhya: Acme Of Scientific Unification.

aham, self, core, nuclear, entity  
ahankara, dynamic self , - potential, self action, self  
motivation  
aikaantha, coherent, synchronised, solid, monotheistic  
aikaanthikam, ultimate, final, supersymmetry, coherent  
aiswarya, controlling , - power, -acceleration, superiority  
aith, variety of colours  
ajnana, inability to , - discriminate,  
notunderstand, unable detect  
akaranam, without cause, self-similar,  
self motivated , endless cause  
akhyatam, explained, made, known, enumerated  
akrith, action, unheard, shielded, submerged  
alocana matra, detectable , frequency, level of , awareness  
ambakam, radiant spectrum, vapourous, radiation, fluidic  
amith, boundless, infinite, ,  
anekam, plural, many, multiple,  
anithyam, uncertain, temporary, fugitive,  
anyonya, mutual, each-other, ,  
anth, last, least, lowest, end  
anumanam, inference, derivation, conjecture,  
anushravik, standard, classical, sacred , - tradition  
aparishesh, exact, no remainder, no overlap,  
apaarthha, potentialless, useless, pointless, meaningless  
apavarg, coherence, synchronised, final beattitude,  
fullfilment  
apnothi, accomplish, effect, secure, ensure  
aptavacanam, axioms, truths, ,  
aptha, reliable, trustworthy, appropriate, fit  
arambhah, beginning, work, haste, effort  
artha, potential, motive, use, value  
asath, nonfact, incorrect, unreal, nonentity  
ashakthi, asynchronous, unharmonius, inability, weak  
ashraya, resting place, ashram, an authority,  
ashrayinah, resting state, static, ,  
ashritham, supported, aided, alternatively, recourse

Secret Of Sankhya: Acme Of Scientific Unification.

ashta , eight, , ,  
asth, spreading, diffusing, setting, waning  
asthi, expansive, setting, dwindling, reducing  
ath, to, go, move, constantly  
ath, move, constantly, dynamic, oscillate  
athindriyam, imperceptible, prasidhi, success, fame  
auth, anxiety, zeal.  
avadhaath-n, clean, pure, white, oiustanding  
avaghahathey, plunges to a point, intense stress  
avastha, state, circumstance, ,  
avasthith, place, location, state, circumstance  
avayavam, mass, body, limb, portion  
avighatha, acceleration, unhindered, unobstructed,  
avikara, no change, static, inanimate,  
avikrithi, fundamental, elemental, unchanging, static,  
absence  
aviparyay, not inverted, unchanged, constant ,no error,  
avishudhi, imperfect, not-purified, distorted  
aviveka, undetectable, dull-witted, lack-of-  
wisdom/judgement  
avyaktha, unmanifest, undetectable, fundamental, indistinct  
avyavam, mass, body , limb, part  
avyapi, non, -pervasive, localised, contained  
awadha, weak, low, disagreeable,  
bhagya, destiny  
bhandha, confinement, bonding, restraint, result  
bhava, kinetic charge, wave form, manifest forms, temper  
bhedey, interruption, breach, conversion, change  
bhoga, use, experience, absorb , rule  
bhra, support, fill, hold, nourish  
bhuddhi, potential, coherence, will, contained wisdom  
bhutadi, particle  
mass, conglomerate , elements,  
bibhritha, change , fragment , reduce,  
cha, and, alone, moreover, nevertheless  
chalam, shuttling, shaking, unsteady, mercury

## Secret Of Sankhya: Acme Of Scientific Unification.

chakrabramha, flywheel, potters wheel, lathe, inertial wheel  
charithartha, successful, contented, balanced, synchronous  
charathi, oscillate, vibrate, move, shake  
chenna, were it not, but for, if it wasn't, un necessarily  
chetana, awareness, consciousness, life, intellectual  
dhanam, divergent, dividing , charity, straighten  
dharshan, detection, sight, visibility,  
dharshayithwa, desire to be seen  
dharanna, superpose, keep in mind, possession,  
dharma, axiom , principle, law, reverence  
dharmadinam, first principles, axiomatic law,  
natural law, basic behaviour  
dhathu, singularity, element, soul, humour  
dhi, receptacle, , end, of  
dhrisht, perception, detection, evaluation, observation  
dhrith, solid, firm, static, contented  
dhu:kha, stress, pressure, force, pain  
dhurath, far, away, distant, remote  
dhurath, away, distant, remote, far  
dhvara, by means of, medium, through,door  
gamanam, leading to, , ,  
ghora, interactive , turbulent, violent,  
grahanath, acceptance, comprehension, ,  
guna, interaction, selfsimilarity , state of action,  $gu=3$   $na=5$   
harya, accelerate, transport, carryoff,  
hethu, exists, motive, impulse, means  
hethumat, effect, , ,  
indriyaghatan, sensory obstruction, , ,  
ishvara, triggered resonant vibrations, accelerative,  
creator, sustainer  
ishtam, appropriate, as, required, result  
ishti, trigger input, sacrifice, desired object, target  
janana, creation, birth, origin, life  
jijnaasaa, investigation, inquiry, inquisitiveness, curiosity  
jna -na, self-potential, coherent potential, wisdom,  
sentience

## Secret Of Sankhya: Acme Of Scientific Unification.

jnaanama, potential sink, ground state, information source  
ka, vapour, fire, air, sun  
kaivalya, unhindered, freedom, exclusiveness, individuality  
kala, time,  
kalaladhya, instant of time, quickness, moment,  
karana, cause, bond, motive, element  
kalpa,  
karannam, an act, bonding, instrument, sensory  
kaaryam, action, duty, work, effect  
kas, approach,  
kevalam, absolute, solely, solitary, only  
krith, sharp cut, pulsing action, square-wave, vibration  
krithsnam, whole, total  
kshya, attenuated, decline, dwindling, resting  
lakshanyam, similarity, quality, definition, subject  
laghu, swift, light, small,  
laya, absorption, concentration, superpose  
linga, coherent state, super position, field-potential, inertia  
mah, fluid, water, freedom, happiness  
mahadh, impulse, intense, massive, acceleration  
mano, mind, mentality,  
matapithraja, organic, mother-father, flexible,  
maya, measured movement, illusion, magic, decept  
maye, consisting of, comprising, whirling, circular motion  
mey, to exchange, interact, oscillate,  
mith (mithya), measure, proof, averaged, weight,  
mithuna, association, pair, twins, union  
moola, origin, basic, root, capital  
moolaprakrithi, unit of activity, fundamental, inertia,  
muchyathe, released, loosened.  
muddha, superposed, dense, inertia, massive  
naha, confinement,  
naimi, circumference, globe, thunderbolt,  
nama, sink, bend, bow  
nana, various, different, -places, distinct  
nasthi, non existence, , ,

## Secret Of Sankhya: Acme Of Scientific Unification.

natavad, synchronous, rythmic, movement,  
dramatics, dance steps,  
nimitha, target, mark, motive, cause  
nirupa, maximal, unmatched, peerless, absolute  
nivartha, return, cease, inactive, repent  
nivrithi, cover, hide, surround  
nivrithth, source,return, depart, hidden, quiet.  
niyath, restrained, subdued, temperate, attentive  
niyam, limit, restraint, rule, certainty  
paratantra, dependant, subservient, supportive,  
pari, additional, inclusive of, against, towards  
pariman, measure, weight, value,  
pariyantham, limit, extreme, end, boundary  
parisesham, conclusion,remainder,supplement  
paroksham, abstraction, inferential, mental effort,  
pashyathi, taken away, robbed, lost, forced  
pra, intense, superb, excellent , complete  
prabhutais, energy source, origin , source,  
pradhana, primary force, predominant, fundamental  
pradhipa, light, elucidation  
prakasha, radiant, expanding, manifesting, intense-light  
prakrithi, resonance, oscillatory, dynamic state, hadron  
pramani, logic, measure, limit, evidence  
prapnothi, attain, reach, fulfill,  
praptey, attainment, acquisition, range, collection  
prasang, attachment , intercourse, occupation, subject  
prasangena, incidentally, superficial, ,  
prasava, creation, generation, source, progeny  
prathi, reference, concerning, against, opposite  
pravarthathe, initiating, startng action, prompting,  
conducting  
pravrithi, interface, connection, flow, commencement  
prayojanam, active part, purposeful, creativeness, causative  
preksakavad, spectatorlike, indifference, unconnected,  
remote  
prekshaka, background, spectator, ,



## Secret Of Sankhya: Acme Of Scientific Unification.

preethy, expansive, buoyant, pleasure, favour  
puman, nuclear, nucleus, potential, male  
puna, again, repeat, but, on the other hand  
Purusha, nucleus , core, static pot, measure  
purvakam, origin, preceeding, source, foremost  
raga, spectrum, colour, passion, musicalnote  
rajah, shuttling action, interaction, oscillation, vortex  
rupa, form, type, geometry, colour  
saadhya,attainable,possible  
saha, sustained, patient, able,  
sakriyam, active, dynamic, mobile,  
sakthi, bonding, contact , attachment,  
sama, synchronous, even, identical, common  
samanabhihar, camouflage, remove detail, ,  
samanvaya, natural order, sequence, application,  
sam-anya, synchronised, exactly, perfectfit, fit  
sambhava, origin, possibility, agreement,  
samipayad, adjacent, close, in, vicinity  
samsar, spectrum, manifestation, phenomenon, world  
samsidhi, total , - resonance, accomplished,  
samya, true, exact, moment, proper  
samyama, synchronise, equal, restraint, simultaneous  
samyog, combination, alliance, connection,  
samyach, all, tru, whole, together  
sankalpakam , autonomous , -response, ,  
sankhya, unification, resonance, component, logic  
sanskara, reactions, momentum, experience, process  
sapta, sevens, spectrum of 7, ,  
sarga, creation, resolution, nature, spectrum  
sarva, complete, whole, all, full  
satkaryam, lawful, correct, axiomatic, hospitable  
sathwa, expansion, vector, tensor, radiant state, vapour,  
virtue  
savayavam, composite, conglomerate, with, limbs  
shaktasya, ability, powerful, skilful, clever  
shakya, possible, directly, express,

## Secret Of Sankhya: Acme Of Scientific Unification.

shanta, synchronised, harmonious, coherent, laminar  
sharira, mass, substance, corporeal, body, soul  
sheshani, remainder,  
shayayuktha, attenuated, resolution, weakening, force  
shodasa, sixteenth, , ,  
shreyan, appropriate, preferable, harmonious, correct  
shrutir, facts, data, information, report  
shwara, resonance, tone, vibrations, sound  
siddhi, resonant, proven, verified, contained skill.  
sukshma, field-subtle, sharp, exact  
sukshmasteshm, mobile field, , ,  
suthra, logic, thread, aphorism,  
syu, bonded, woven, sewn.  
svabhava, selfsimilar, own-state, state of rest, internal stress  
svarupam, positive, natural, normal,  
svastha, coherent, firm, contented,  
svayambhu, selforganise, existent, self, initiating  
Thaama, compressed, contracted , static mass, darkness  
thathva, reality, facts, basic nature, elemental  
thaijasa, rajasic state, self sustaining , particle, field  
thanmatra, vorticate, dense field, static potentl, particle  
state  
thanvo, synchronised, superposed, weave, spread  
thena, then, consequently  
thesham, focussed, sharp , pointed, dense  
thraya , three modes, three orders, cubic  
thiguna, tri-vector, tensor, vector, self-similar  
thrishapta, 343, 7 cubed, ,  
thrividham, triple, threefold, triad,  
ubhayam, both, duality, plurality, usefulness  
uhah, explanation, understand , knowledge, ellipsis  
upabhogam, use,enjoyment  
upadhana, material cause, taking, ,  
upakar, supportive , helpful, obliging,  
upalabdi, detection, knowledge, gain, sensing  
uparamathy, stopped, dead, death, cessation

Secret Of Sankhya: Acme Of Scientific Unification.

upayair, correction, expedient, reaction,  
upekshak, neglect, indifference, ,  
urdhwa, rising up , expansive, ,  
uthpadhyam,  
uurdhvam, rising , upward, ,  
va, radiate, blow, ,  
vachaaspathi, blow & shine , photon, light, power  
vaasthu, rest mass, house, residence,  
vachaspathi, powerful, brilliant, brihaspati,  
vad, to, speak, to, shine  
vaikritha, accelerative , intense change , hideous,  
vairagya, neutral, balanced, objective, no preference  
vasha, submit, subdue, influence, wish  
vasthu, substance, reality, subject, component  
vayogan, resonance, dynamic union , active meshing ,  
vibhuthi, strong force, super strength, welfare, wealth  
vidhair, controllable,  
vighata, collision, obstruction , destruction, impact  
vijnana, dynamic, kinetic potential, wisdom, business  
vikaaro, radiant, accelerative, distorting,  
vikrithi, harmonic-oscillator, expansive, change, distort  
vilakshana, different , puzzling, ,  
vimokshana, emancipation, setting free, release, no  
restraints  
vina, without, except, ,  
vinivrithi, decaying, subdue, restraining, reducing  
viparitha, contrary, contrast, alternative, mistake  
viparyaya, dynamic, interactive, changing, reversal  
viraga, phase-change, change-colour, disinclination,  
virupam, negative, deformed, not, natural  
vishala, expansive, large, great,  
vishaya, phenomena, sensory, object, scope  
vishesha, species, distinctive, peculiarity,  
vishith, sharp, precise , ,  
vishudha, undistorted, pure, ,  
vishwa, universe, cosmos, ,

Secret Of Sankhya: Acme Of Scientific Unification.

vrityashrava, self-rotating, & resting , state, selfresonant  
vrithi, vortex, photon, oscill. cycle, circ. movemnt  
vyakta, manifest, detectable, secondary, plural  
vyathishtathe, potent, exchange  
vyavadhan, occultation, screening, interval  
yatha , as, like, for instance, so that, presence, these  
yasmath, by striving , by forcing  
ye, state, presence, these  
yukthi, joined,connected,mixed-up,verbal arrangement

## Index

To be completed after correcting all pages.

## Secret Of Sankhya: Acme Of Scientific Unification.

### Symbols & Definitions.

Cps= Counts of interactions per cycle. The cycle is fixed at 10 counts or a circular period of  $2\pi$  .

Fcp=fractional count per cycle. Mass counts are shown as fractional counts All interactive counts that synchronise and also those that become coherent act in groups or as simultaneous counts. These have mass characteristics and form ground states of 'resting potential' that absorb interactive counts.

$K_x = \text{Purusha} = 0.91498794 \text{ Fcp}$ . Can be equated to MKS units if the second is set to fc at the measured velocity of light. The largest coherent unit of cyclic time-period and is equated to the maximum inertia, mass or delay as the ground state. It is the Andhathaamshra or blackhole state.

$M_y = \text{Moolaprakrithiy} = 1.34462022\text{E-}51 \text{ Fcp}$ . The smallest cyclic unit of activity. The elemental perpetual quantum oscillator and is equated to the fundamental unit of charge.  $M_y$  in simultaneous activity-groups depict mass. All counts are only in terms of the  $M_y$  value and therefore dimensionless

$M_{ps} = \text{Mahadprakriti} = 2.20369\text{E-}8 \text{ Fcp}$  or the largest dynamic mass. It depicts the break in the coherent state and start of the synchronised state. It forms the base or reference point for all interactive measurements in the Thaamishra or dense massive region. It provides the coherent potential to initiate activity by converting the coherent state into the synchronous phase by an interactive exchange of Vikrithi states. The  $M_{ps}$  equals the Planckmass in value and the  $\text{Vikrithi} = M_e$  equals the electron in mass value.

$PM = \text{Prakrithi saptha}$  or the active nuclear spectrum. Its value is  $1.67442318\text{E-}27 \text{ Fcp}$ . The  $M_{ps}$  ends its synchronous state at this value. Below it the interactive states are either resonant or radiative. Above this state the potential rises in steps of nuclear units of dense or

## Secret Of Sankhya: Acme Of Scientific Unification.

potential states. Thaamasic Linga PM is in the changing interface domain of Linga to Bhava. In Physics it represents the Neutron / Proton domain of hadronic states.

Me=Mahadvikrithi =  $9.11023372E-31$  Fcp. The Vikrithi in the Raja spectrum are resonant and transmigratory states. It represents the reactive, observable and detectable units of interactive outputs. The Me forms the reactive phase output when the Mps state is triggered out of its coherent or synchronous state. The Me reacts at the PM interface as a result of an Mps interactive initiative. It depicts the leptonic state of an electron that interacts and transmigrates in the resonant domain.

Ne=Vikrithi saptha =  $9.52873405E-35$  Fcp. It represents the radiative state in the Raja spectrum. The seven Vikrithi levels are a resonant transmigratory state at the resonant rate of C. The Ne transmigrates as individual resonant states or each Ne forms the node in space for the oscillatory rate of C. It forms the Abhiman section in the Abhiman / Ahankar interface from which radiative Vrithi units are accelerated from energetic interactive states. Ne units continuously and constantly transmigrate to maintain the count balance in the substratum.

Vr=Vrithi in the Vikaro spectrum commencing from  $2.47671856E-35$  Fcp goes upto 7 Ne units or  $6.67011384E-34$  Fcp to initiate a Ahanakar radiative state from the Abhiman/Ahankar interface at the Raja / Satwa interface. Sathvic Vrithis consist of My units accelerated in groups, packages or quanta. A total of  $4.96059312E+17$  My Cps or seven Ne's are needed to cross Abhiman/Ahankar interface and initiate the accelerative process as a simultaneous package or quanta. It is the photon in Physics. Each Ne node is triggered or excited by the My ensemble transmigrating as a Vrithi or Sathvic vorticullar unit. One My count is reduced by absorption at every Ne node vibrating at rate C. Hence the maximum counts that

Secret Of Sankhya: Acme Of Scientific Unification.

aVrithi can transmigrate at rate C is  $4.96059312E+17$  and considering each Ne node is a unit distance apart then the Vrithi expands the quanta of counts in the noted distance. Taking a nodal distance at a metre a part (or a metre wavelength) a single Vrithi or quanta of My can transmigrate  $4.96059312E+17$  metres resonantly for 58.5 years before it is completely absorbed. It corresponds to the Hubble distance / expansion ratio of a Megaparsec.

$P_x =$  Coherent to synchronous interface = 20.9479861 Cps. It represents the Linga to Bhava interface transfer ratio. The coherent Linga state equals the Synchronous Bhava phase at this value. It represents the number counts absorbed or radiated in the change over. It forms the coupling constant at the Thaama to Raja states at the Linga / Bhava interface. In Physics it forms the strong to weak force coupling or Quark / Baryon/ Hadron / Meson / Lepton regions.

$$P_x = \left( \frac{10 \cdot \sqrt{3}}{2 \cdot \pi} \right)^3 = 20.9479861$$

$G_e =$  The ratio of coherent and expansive states at the balanced and unmanifest state. It equates all the three dense states at balance and the radiant states at the transitional state.

$$G_e = \frac{7^2}{K_x \cdot r_s \cdot 2 \cdot (2 \cdot \pi)^2} = 0.664687$$

$KV =$  ratio first volume change =  $1 / (k-1)^3 = 56.94762837$

$B_t =$  ratio volumetric/geometric state =  $KV / P_x = 2.718$

$G_e =$  ratio coherent/expansive =

$K_7 =$  ratio linear/volume change =  $7 / (k-1) = 26.93125471$

$P_1 =$  ratio radial/cyclic changes =  $10 / 2 \pi = 1.59154943$

$P_7 =$  ratio linear/radial change =  $7 / 2 \pi = 1.1140846$

Secret Of Sankhya: Acme Of Scientific Unification.

Rs=rs=decay in infinite time=1.02040816  
 MU=Mass of Universe=7.81711993E+52  
 RU=Space radial count=5.99334E+25  
 TT=Space time-cycle=2.020845E+17  
 DD=Space critical density=3.631115E-25  
 Dp=Mahad density=4.569102E+96  
 Lp= Mahad radial count=1.68956E-35  
 Tp=Mahad time cycle=5.696886E-44  
 Rp=Nuclear radial count=5.089059E-15  
 Pg=accleration ratio in nucleus=4.359977E-9  
 GU=acceleration ratio in flat space=1.467584E-9  
 Pt=Nuclear time cycle=0.00108038  
 Vp=Nuclear flux ratio=4.71043347E-12  
 Vm=Electron flux ratio=3.5924965365E-13  
 Tm=Electron time cycle  
 Pd=Nuclear density=1.2704356353E+16  
 Dm=Electron density=8.4457260215E+15  
 GL= Galaxy=  $(c^{1+x})^3=1.33E+41$ .  
 Hu=Hubble ratio=  $\frac{Ly}{55000} = 5.5474683410^{17}$  ■  
 h=Plancks constant =6.626E-34  
 C=Velocity of light = 2.99792459E+8  
 Alpha=Fine structure coupling constant=.00729735  
 Eo=Electronic charge=1.5188981E-14



Secret Of Sankhya: Acme Of Scientific Unification.

## Secret Of Sankhya: Acme Of Scientific Unification.

### References

- “The Sankhya Karika” by Ishwara Krishna Translated by H.T.Colebrook.
- “Classical Samkhya” by Gerald Larsen.
- “Brahma Sutras” by Swami Sivananda
- “Anthology of Vedic Hymns” by Swami B.Saraswati
- “Rig Veda” Anthology translation
- “Atharva Veda Samhita 1 & 2” by W.D. Whitney
- “Atharva Veda Pratisakhya” W.D. Whitney
- “The Atharva Veda” by Devichand
- “Hymns of the Atharva Veda ” by Max Muller
- “The Vedanta Philosophy” by Max Muller
- “The Bhagavadgita” by Dr. Shakuntala Rao Saastr.
- “On The Bhagavad-Gita” by Maharishi Mahesh Yogi
- “Srimad Bhagavatham” by Swami Prabhupada.
- “The Science and Philosophy of Religion” Swami Vivekananda
- “Thoughts on Vedanta” by Swami Vivekananda.
- “Siva Sutras” by J.Singh
- “The Arctic Home In The Vedas” by Lokmanya Tilak
- “Vedic Mathematics” Swami Bharathi Krishna”
- “The Heart Of The rig Veda” by M.R.Gopalacharya
- “Saundaryalahari Sankaracarya” by V.K. Subramaniam.
- “Nine Principles Of The Upanishads” by Sw. Kriyananda
- “The Karma Mimamsa” by B.Keith.
- “Dimensions of Renunciation in Advaita Vedanta” by N.Tiwari
- “The Science of Yoga” by I.K.Taimini.
- “The Yoga System of Patanjali” by J.H.Woods
- “The Yoga Sutra” by G.Feuerstein
- “Light of Yoga” by B.K.S. Iyengar.
- “Meditation and Mantras” by Swami Devananda
- “Devatma Shakti” Swami Maharaj
- “Introduction to Sahankara” by R.Das
- “Rigveda and the Indus Valley Civilisation” by B.Prakash
- “The Mysterious Kundalini” by V.G.Rele.

Secret Of Sankhya: Acme Of Scientific Unification.

- “The Kularnava Tantra” by Sir John Woodroffe  
“The World as Power” by Sir John Woodroffe  
“The Meaning of Relativity” by A. Einstein.  
“Gravitation” by M.T.W.  
“Concepts of Particle Physics” by Gottfried & Weisskopf  
“Blackholes TMP” by Thorne, Price, Macdonald.  
“Gravity, Particles and Astrophysics” by P.S Wesson  
“Heat Transfer” by S.P. Sukhtame.  
“The Holographic Universe” By Micaheal.Talbot.  
“Different Approach to Cosmology” by Hoyle, Burbigde  
& Narlikar  
“Concepts of Particle Physics” 1 & 2, by Gottfried &  
Weisskopf.  
“Quantum Gravity” by Isham, Penrose and Sciama  
“Fields and Waves” by Ramo  
“Supergravity” Proceedings.  
“Supersymmetry and Supergravity” by P. West  
“Search for Gravitational Waves” papers from ACIF  
“Particles and Gravity” by John Hopkins Workshop  
“The Search for Gravity Waves” by P.W.Davies  
“Gauge Theory” by Moriyasu  
“The First Three Minutes” S.Weinberg  
“The Unified Model Of The Universe” by S.Sheeter  
“The Evolution Of Physics” by Albert Einstein  
“Surprises in Theoretical Physics” by R. Peierls  
“Gravitation, Cosmology, and Cosmic Ray Physics” by  
NRC  
“Einstein’s Universe” by N.Calder  
“Space, Time and Gravity” by R.M.Wald  
“A Brief History of Time” by S.Hawkins  
“The Omega Point” by J.Gribbin  
“Beyond Telepathy” by A. Puharich  
“The Human Brain” by I Asimov  
“The Iceland Papers” A.Puharich  
“Life Energy” by John Diamond  
“The Discovery of the Electron” by D.Anderson

Secret Of Sankhya: Acme Of Scientific Unification.  
“Elementary Particles “ by Frisch/Thorndyke

“Structure of Atomic Nuclei” by C.S. Cook

“ Special Theory of Relativity” by R.Katz

Scientific Papers from the Web .  
580